

Photometric Test Report



ECLDISPLAYUNFC

ZOOMABLE PROFILE LENS 20-40°

40W RGB+WW LED gallery light, Tunable White
and Full Colour with universal control

DMX / Dali T8 / Knob-dimming /

Phase-cut dimming

CONTENTS

Table of contents	2
Testing process	3
Color preset Full On Max Zoom	4
Color prese Full On Min Zoom	7
Color preset Red Max Zoom	10
Colo preset Red Min Zoom	13
Color preset Green Max Zoom	16
Color preset Green Min Zoom	19
Color preset Blue Max Zoom	22
Color preset Blue Min Zoom	25
Color preset White Max Zoom	28
Color preset White Min Zoom	31
Color temperature 2800K Max Zoom	34
Color temperature 2800K Min Zoom	39
Color temperature 3200K Max Zoom	44
Color temperature 3200K Min Zoom	49
Color temperature 4000K Max Zoom	54
Color temperature 4000K Min Zoom	59
Color temperature 5600K Max Zoom	64
Color temperature 5600K Min Zoom	69
Color temperature 6000K Max Zoom	74
Color temperature 6000K Min Zoom	79

TESTING PROCESS

Prolights has its own optical testing laboratory in order to provide accurate photometric reports for its lighting products. The testing laboratory contains certain variety of precise lighting measurement systems that ensure an optimal reading of all the characteristic parameters of the lighting devices. All measurements are made at a controlled room temperature of 20°C without any external light sources. This photometric report is obtained through the data measured by a high precision measurement system and analyzed by a dedicate software.

Prolights measurement instrument

Prolights measurement instrument is a complete measurement system for any light source. It's equipped with two-axis goniometer, that enables to measure the full 3D distribution field of the light source. This instrument measures the light intensity, the beam angle and the most significant colors parameters, like color temperature, spectral distribution, CRI, CQS, TM-30 with a very high accuracy rate.

Please Note: All measurements are made with light source at operating temperature. Before starting the measurement, the instrument analyzes the process of the light source during the heating phase. The measuring process of all the parameters begins only when the light emission is stable, that is with a variation of less than 0.5% in a 15 minutes time frame.

Prolights measurement software

The software provides user friendly interface for the operator who does the measurements, and it also analyzes and processes all the collected data by the instrument. With this software it is possible to see the measured data in real-time and it is possible to examine all the measured data and graphics afterwards as well. All information is collected in a specific Prolights template, and the software creates also IES and LDT files, which are widely used to transfer the photometric data, and to develop lighting system.

Additionally, the fixtures are rechecked using various hand-held instruments like Sekonic C-700 and Gossen Mavospec Base, this is done to ensure, that the data in the photometric report are as accurate as possible.



Total lumen output:

325 lm

Peak candela output:

1047 cd

PRODUCT NAME:

ECLDISPLAYFC

MEASUREMENT CONDITIONS:

Beam angle:

Profile Max Zoom

Target:

Full On

Operator:

Paolo Carvone

Date and time:

03/12/2020 16:57:35

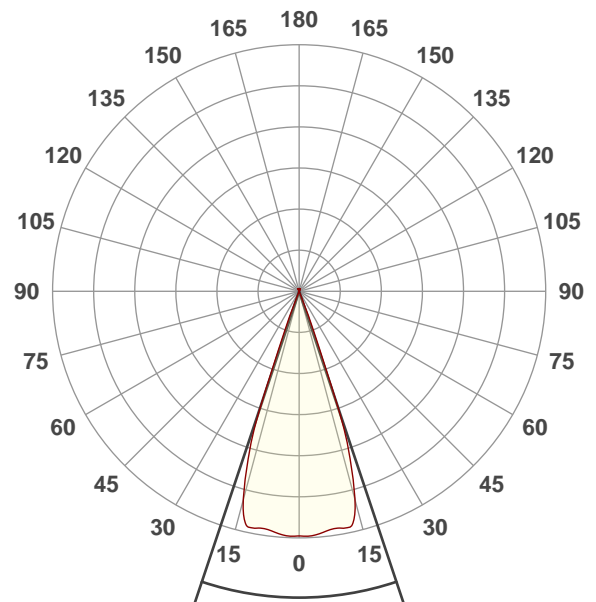

Beam angle 50%: 37°

Field angle 10%: 41,6°

Cut off angle 2.5%: 43,2°

Spectra

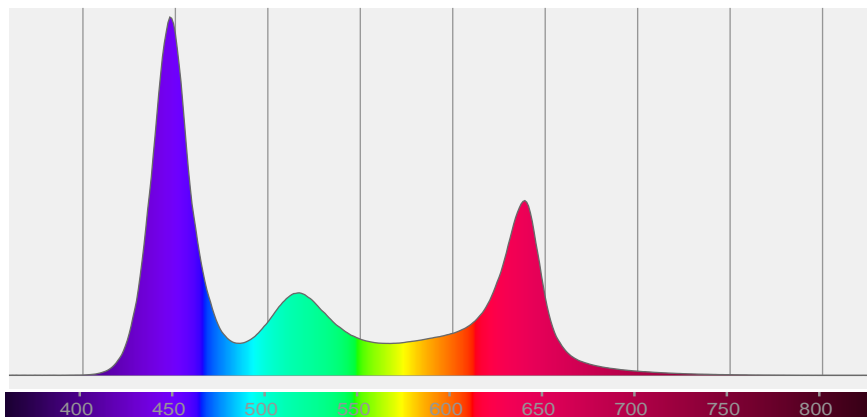

BEAM DETAILS



Beam angle 50%	Field angle 10%	Cut off angle 2,5%	Intensity ratio in 120° cone	Intensity ratio in 90° cone
37°	41,6°	43,2°	100,0%	100,0%

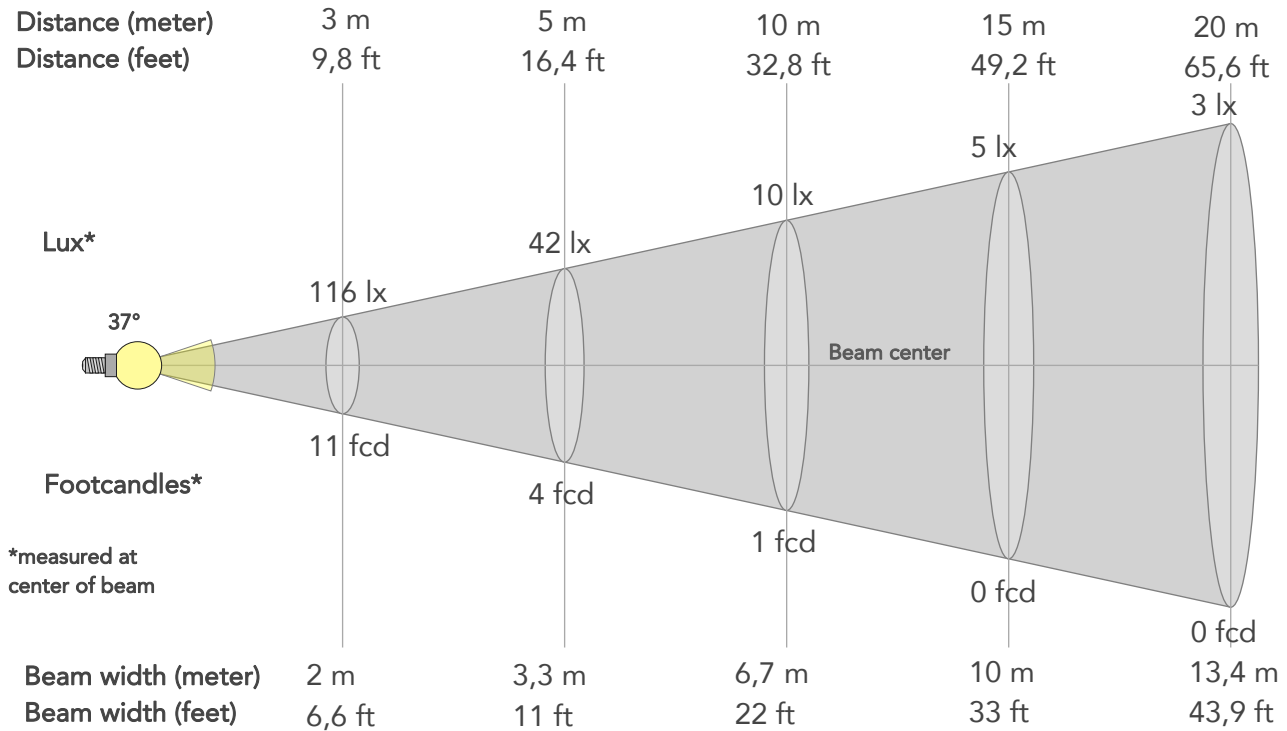

BEAM INTENSITIES AND WIDTHS

Distance	1m	2m	3m	4m	5m	7,5m	10m	15m	20m	25m	30m	40m	50m
Distance	3,3ft	6,6ft	9,8ft	13,1ft	16,4ft	24,6ft	32,8ft	49,2ft	65,6ft	82ft	98,4ft	131,2ft	164ft
Lux	1045lx	261lx	116lx	65lx	42lx	19lx	10lx	5lx	3lx	2lx	1lx	1lx	0lx
Footcand.	97fcd	24fcd	11fcd	6fcd	4fcd	2fcd	1fcd	0fcd	0fcd	0fcd	0fcd	0fcd	0fcd
Beam wid.	0,7m	1,3m	2m	2,7m	3,3m	5m	6,7m	10m	13,4m	16,7m	20,1m	26,8m	33,5m
Beam wid.	2,2ft	4,4ft	6,6ft	8,8ft	11ft	16,5ft	22ft	33ft	43,9ft	54,9ft	65,9ft	87,9ft	109,9ft

LINEAR DISTRIBUTION DIAGRAM

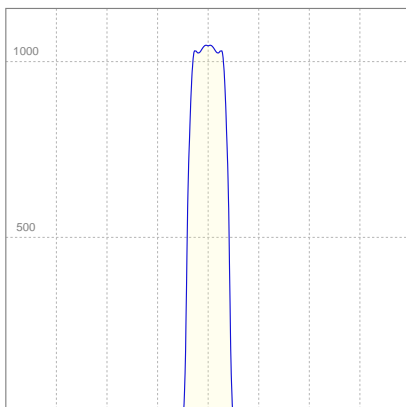

ELECTRICAL SPECIFICATIONS

Input voltage	Input current	Input power	Effeciency
224V	0,166A	34,6W	9lm/W

Power FC
0,93

ISO CANDELA DIAGRAM

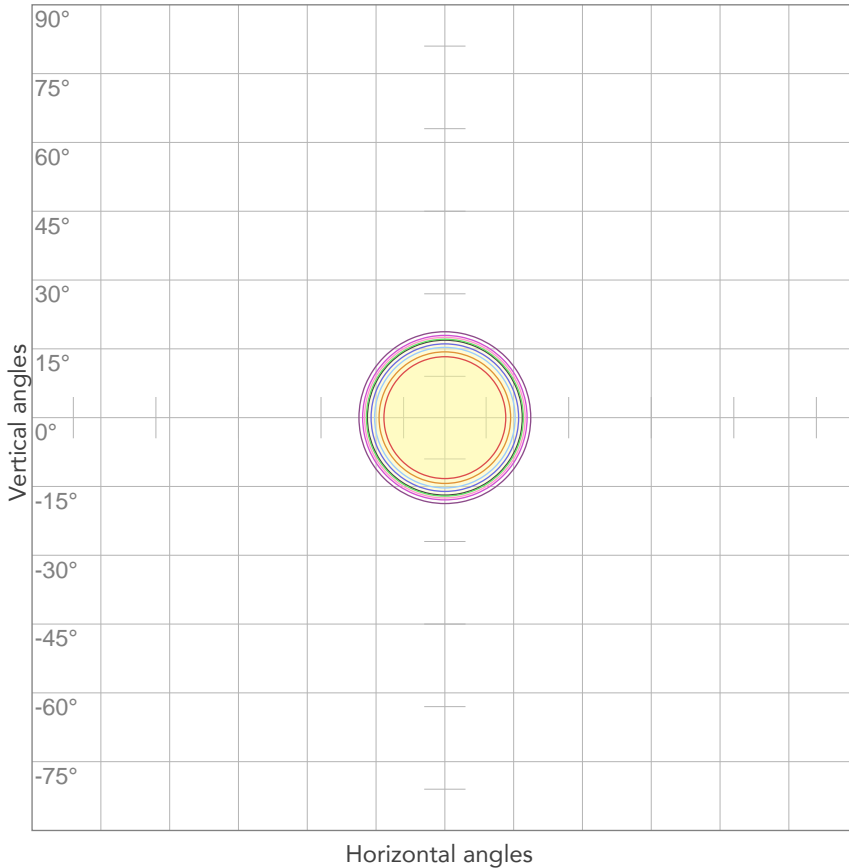

10%	104 cd
20%	209 cd
30%	313 cd
40%	418 cd
50%	522 cd
60%	627 cd
70%	731 cd
80%	836 cd

Conditions:

Number of c-planes: 2

Candela at center: 1045 cd

ISO LUX DIAGRAM

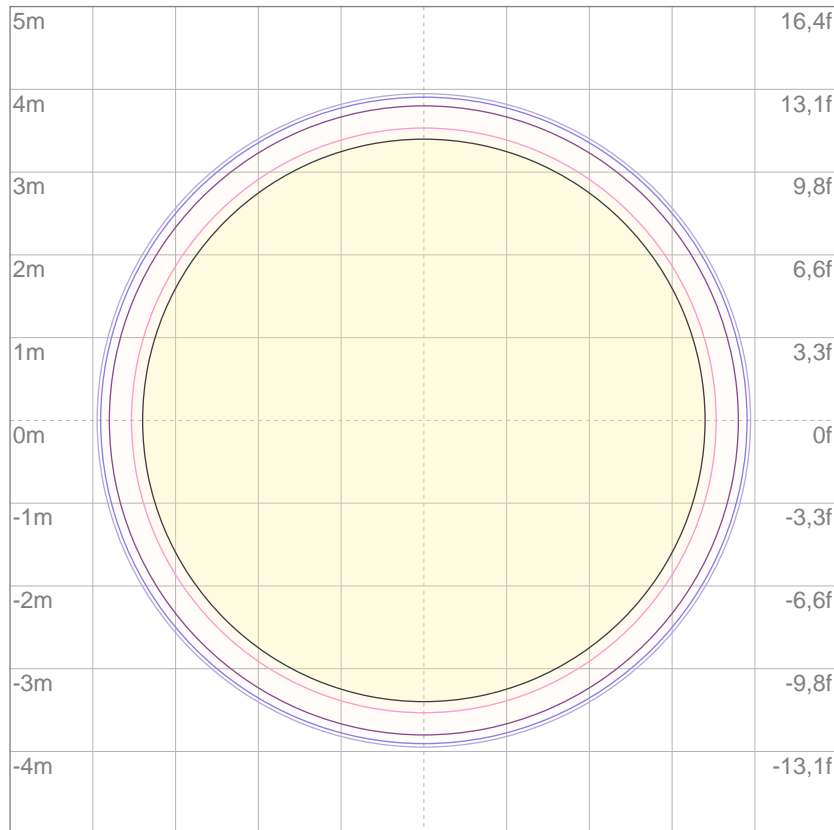

3%	0,313 lx
5%	0,522 lx
10%	1,04 lx
30%	3,13 lx
50%	5,22 lx

Conditions:

Number of c-planes: 2

Lux at center: 10,4 lx

Lux distribution on a surface when lamp is mounted at 10 meters from the surface.

Mounting height: 10 meters (33 feet)



Total lumen output:

366 lm

Peak candela output:

4863 cd

PRODUCT NAME:

ECLDISPLAYFC

MEASUREMENT CONDITIONS:

Beam angle:

Profile Min Zoom

Target:

Full On

Operator:

Paolo Carvone

Date and time:

03/12/2020 16:48:16

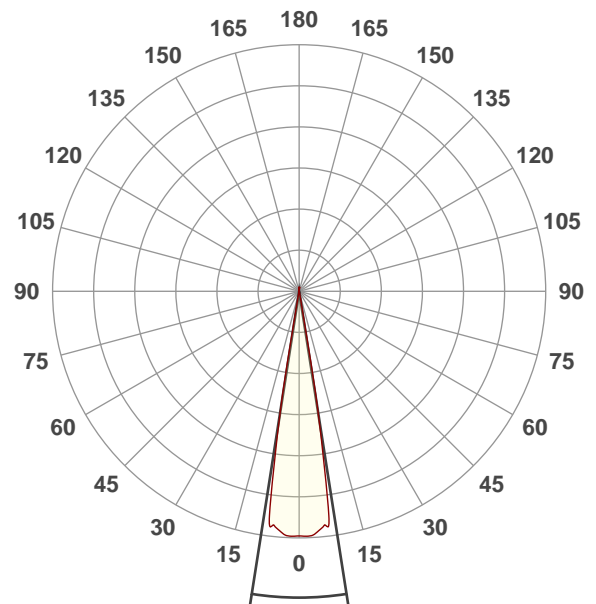

Beam angle 50%: 17,8°

Field angle 10%: 20,4°

Cut off angle 2.5%: 21,7°

Spectra

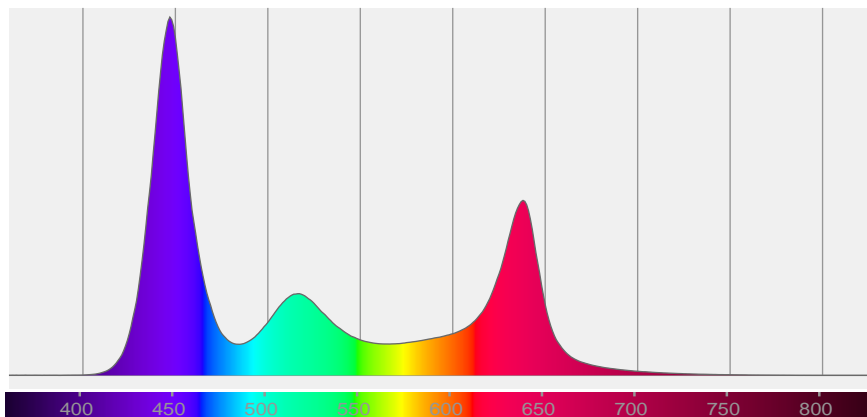

BEAM DETAILS



Beam angle 50%	Field angle 10%	Cut off angle 2,5%	Intensity ratio in 120° cone	Intensity ratio in 90° cone
17,8°	20,4°	21,7°	100,0%	100,0%

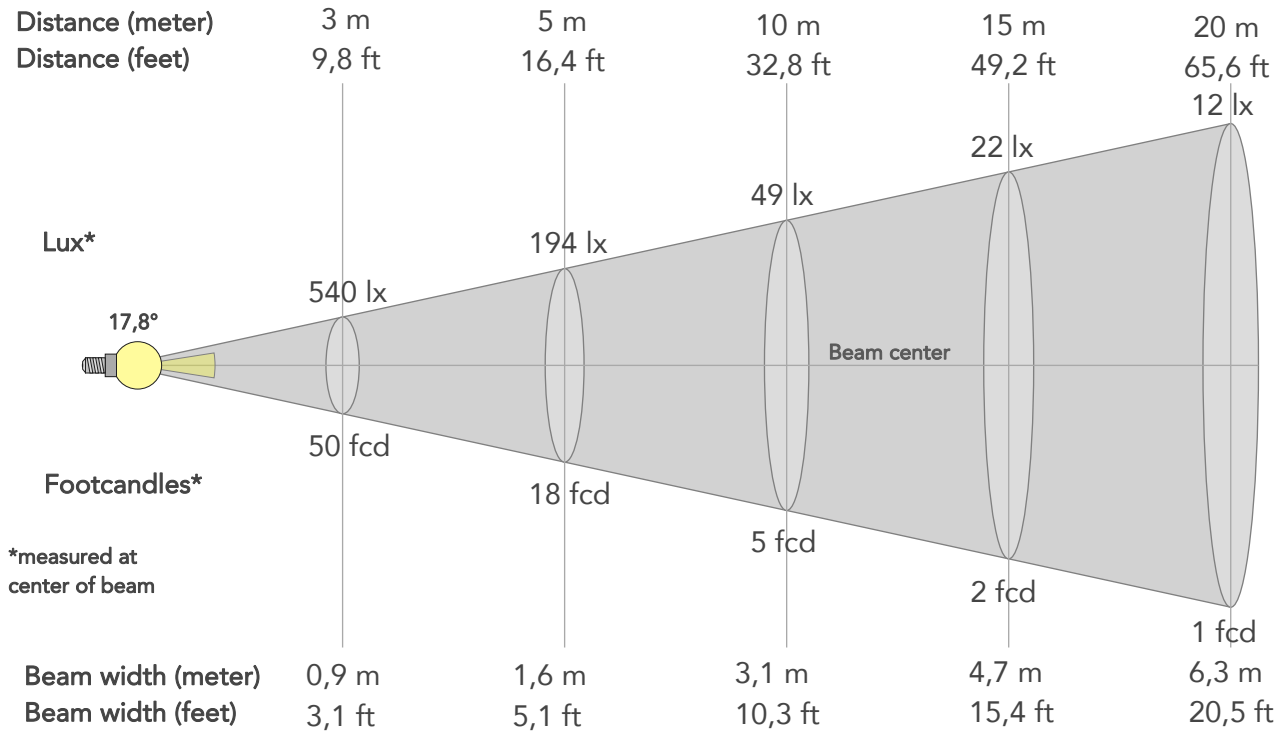

BEAM INTENSITIES AND WIDTHS

Distance	1m	2m	3m	4m	5m	7,5m	10m	15m	20m	25m	30m	40m	50m
Distance	3,3ft	6,6ft	9,8ft	13,1ft	16,4ft	24,6ft	32,8ft	49,2ft	65,6ft	82ft	98,4ft	131,2ft	164ft
Lux	4856lx	1214lx	540lx	303lx	194lx	86lx	49lx	22lx	12lx	8lx	5lx	3lx	2lx
Footcand.	451fcd	113fcd	50fcd	28fcd	18fcd	8fcd	5fcd	2fcd	1fcd	1fcd	1fcd	0fcd	0fcd
Beam wid.	0,3m	0,6m	0,9m	1,3m	1,6m	2,3m	3,1m	4,7m	6,3m	7,8m	9,4m	12,5m	15,7m
Beam wid.	1ft	2,1ft	3,1ft	4,1ft	5,1ft	7,7ft	10,3ft	15,4ft	20,5ft	25,7ft	30,8ft	41,1ft	51,4ft

LINEAR DISTRIBUTION DIAGRAM

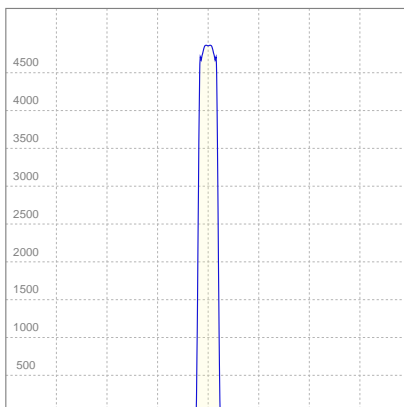

ELECTRICAL SPECIFICATIONS

Input voltage	Input current	Input power	Effeciency
223V	0,168A	35,0W	10lm/W

Power FC
0,93

ISO CANDELA DIAGRAM

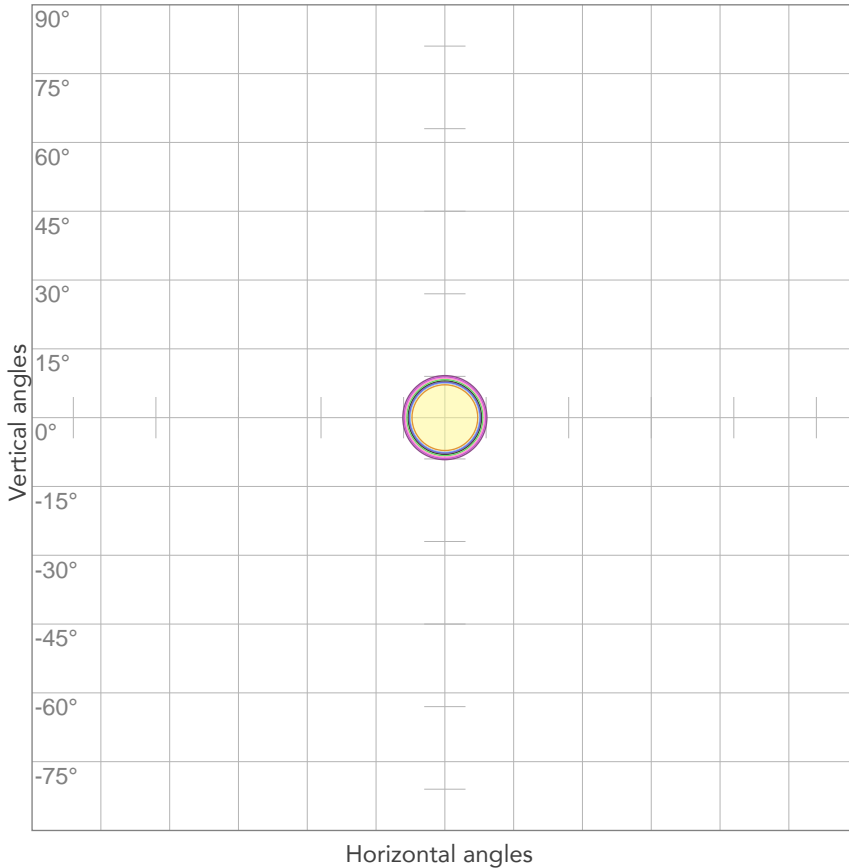

10%	486 cd
20%	971 cd
30%	1457 cd
40%	1942 cd
50%	2428 cd
60%	2914 cd
70%	3399 cd
80%	3885 cd

Conditions:

Number of c-planes: 2

Candela at center: 4856 cd

ISO LUX DIAGRAM

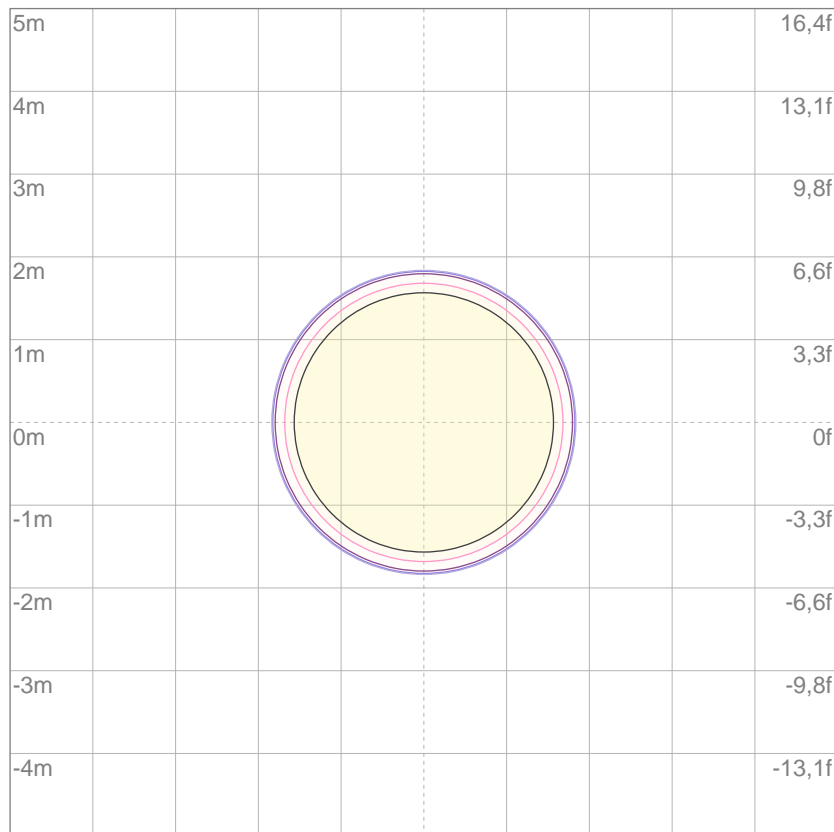

3%	1,46 lx
5%	2,43 lx
10%	4,86 lx
30%	14,6 lx
50%	24,3 lx

Conditions:

Number of c-planes: 2

Lux at center: 48,6 lx

Lux distribution on a surface when lamp is mounted at 10 meters from the surface.

Mounting height: 10 meters (33 feet)



Total lumen output:

75,1 lm

Peak candela output:

245 cd

PRODUCT NAME:

ECLDISPLAYFC

MEASUREMENT CONDITIONS:

Beam angle:

Profile Max Zoom

Target:

Red

Operator:

Paolo Carvone

Date and time:

03/12/2020 16:59:18

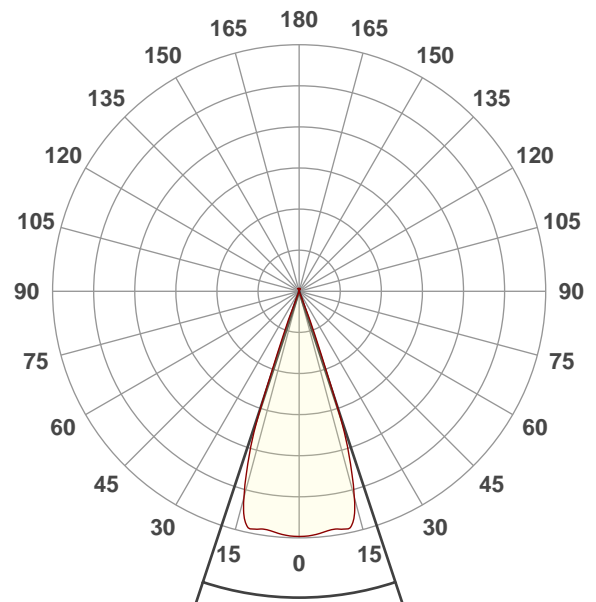

Beam angle 50%: 36,6°

Field angle 10%: 41,5°

Cut off angle 2.5%: 43°

Spectra

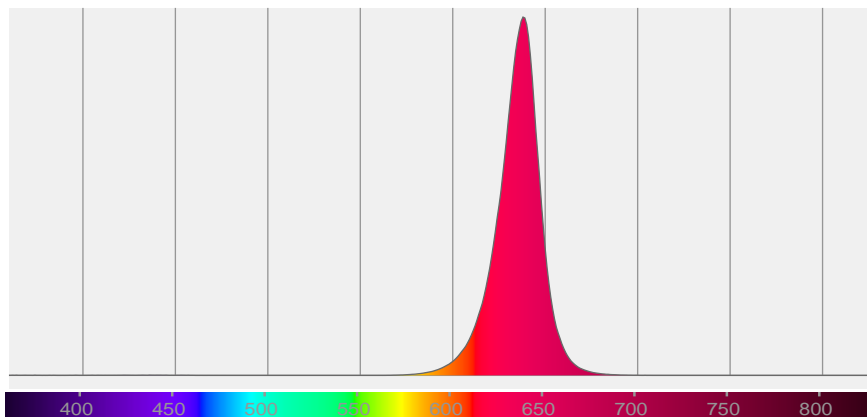

BEAM DETAILS



Beam angle 50%	Field angle 10%	Cut off angle 2,5%	Intensity ratio in 120° cone	Intensity ratio in 90° cone
36,6°	41,5°	43°	100,0%	100,0%

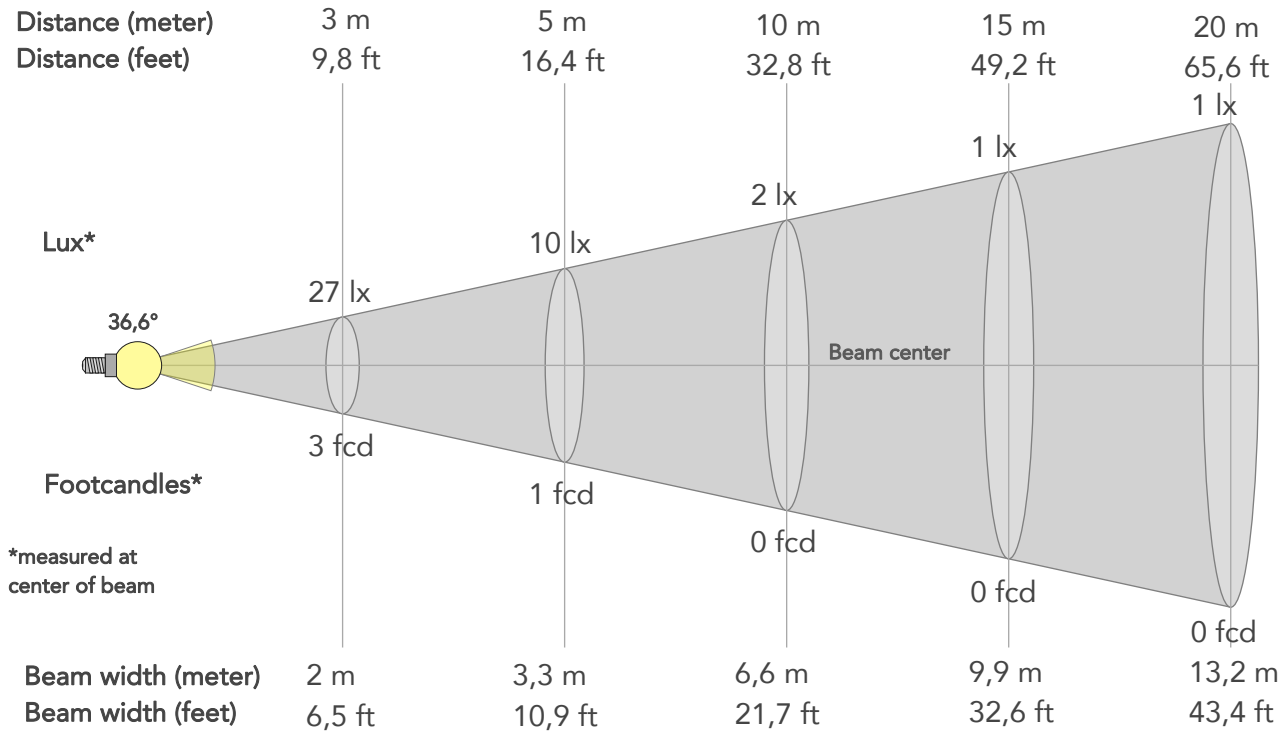

BEAM INTENSITIES AND WIDTHS

Distance	1m	2m	3m	4m	5m	7,5m	10m	15m	20m	25m	30m	40m	50m
Distance	3,3ft	6,6ft	9,8ft	13,1ft	16,4ft	24,6ft	32,8ft	49,2ft	65,6ft	82ft	98,4ft	131,2ft	164ft
Lux	245lx	61lx	27lx	15lx	10lx	4lx	2lx	1lx	1lx	0lx	0lx	0lx	0lx
Footcand.	23fcd	6fcd	3fcd	1fcd	1fcd	0fcd	0fcd	0fcd	0fcd	0fcd	0fcd	0fcd	0fcd
Beam wid.	0,7m	1,3m	2m	2,6m	3,3m	5m	6,6m	9,9m	13,2m	16,6m	19,9m	26,5m	33,1m
Beam wid.	2,2ft	4,4ft	6,5ft	8,7ft	10,9ft	16,3ft	21,7ft	32,6ft	43,4ft	54,3ft	65,1ft	86,9ft	108,6ft

LINEAR DISTRIBUTION DIAGRAM

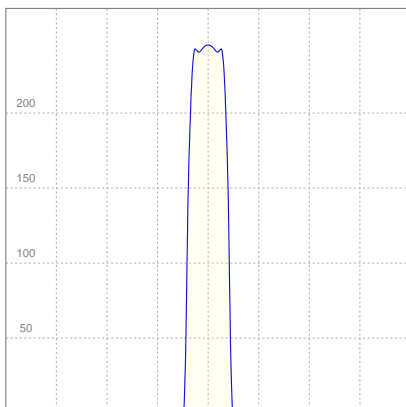

ELECTRICAL SPECIFICATIONS

Input voltage	Input current	Input power	Effeciency
224V	0,073A	14,1W	5lm/W

Power FC
0,87

ISO CANDELA DIAGRAM

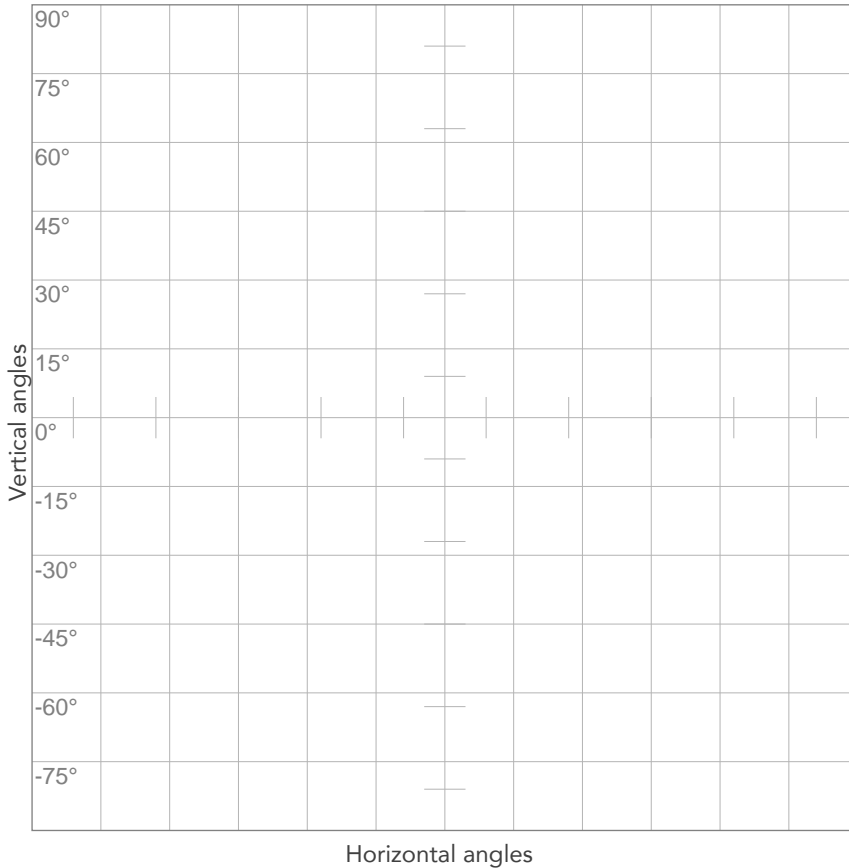

10%	25 cd
20%	49 cd
30%	74 cd
40%	98 cd
50%	123 cd
60%	147 cd
70%	172 cd
80%	196 cd

Conditions:
 Number of c-planes: 2
 Candela at center: 245 cd

ISO LUX DIAGRAM

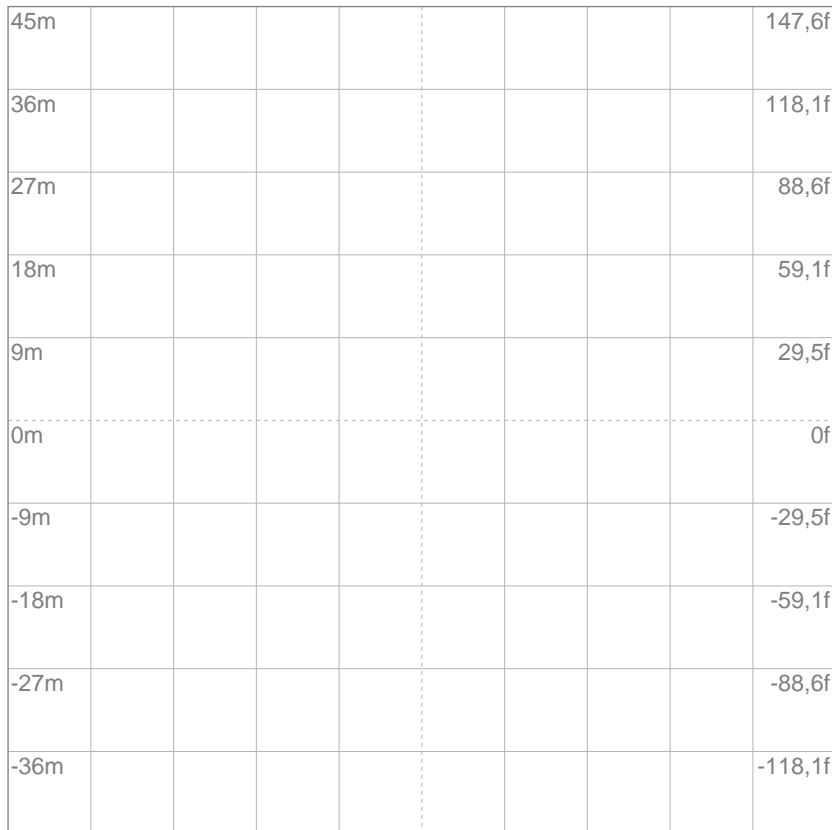

3%	73,6m lx
5%	0,123 lx
10%	0,245 lx
30%	0,736 lx
50%	1,23 lx

Conditions:
 Number of c-planes: 2
 Lux at center: 2,45 lx

Lux distribution on a surface when lamp is mounted at 10 meters from the surface.

Mounting height: 10 meters (33 feet)



Total lumen output:

85,4 lm

Peak candela output:

1141 cd

PRODUCT NAME:

ECLDISPLAYFC

MEASUREMENT CONDITIONS:

Beam angle:

Profile Min Zoom

Target:

Red

Operator:

Paolo Carvone

Date and time:

03/12/2020 16:50:00

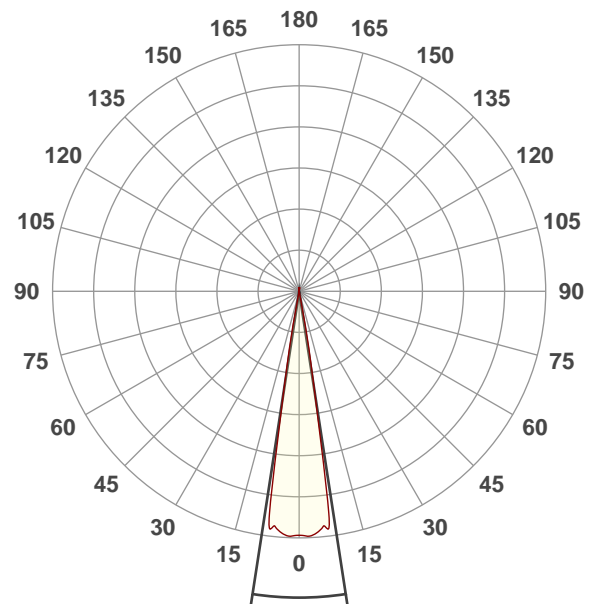

Beam angle 50%: 17,5°

Field angle 10%: 21°

Cut off angle 2.5%: 22°

Spectra

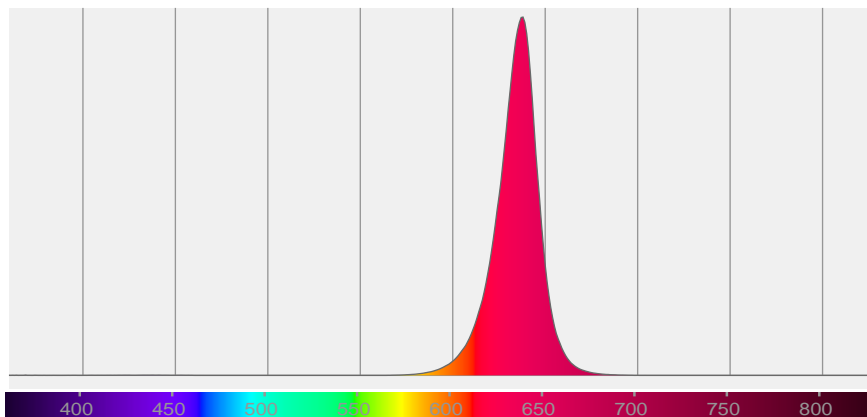

BEAM DETAILS



Beam angle 50%	Field angle 10%	Cut off angle 2,5%	Intensity ratio in 120° cone	Intensity ratio in 90° cone
17,5°	21°	22°	100,0%	100,0%

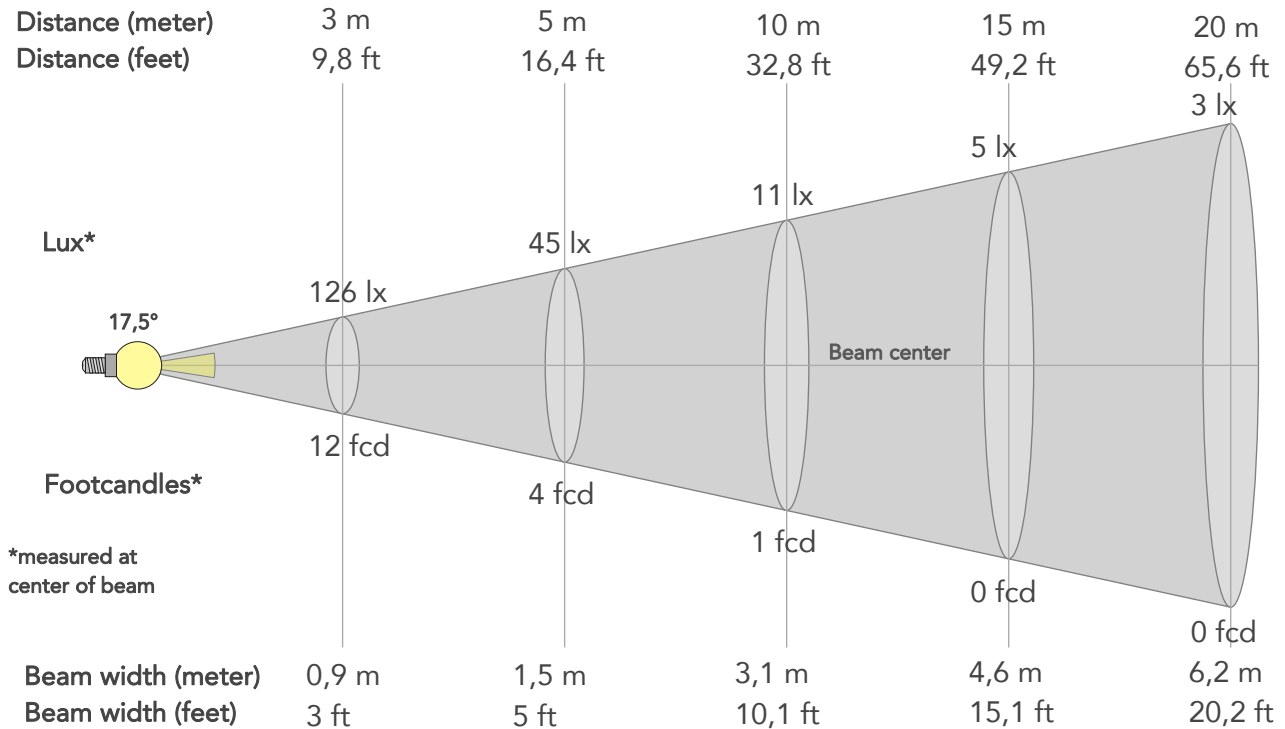

BEAM INTENSITIES AND WIDTHS

Distance	1m	2m	3m	4m	5m	7,5m	10m	15m	20m	25m	30m	40m	50m
Distance	3,3ft	6,6ft	9,8ft	13,1ft	16,4ft	24,6ft	32,8ft	49,2ft	65,6ft	82ft	98,4ft	131,2ft	164ft
Lux	1136lx	284lx	126lx	71lx	45lx	20lx	11lx	5lx	3lx	2lx	1lx	1lx	0lx
Footcand.	106fcd	26fcd	12fcd	7fcd	4fcd	2fcd	1fcd	0fcd	0fcd	0fcd	0fcd	0fcd	0fcd
Beam wid.	0,3m	0,6m	0,9m	1,2m	1,5m	2,3m	3,1m	4,6m	6,2m	7,7m	9,2m	12,3m	15,4m
Beam wid.	1ft	2ft	3ft	4ft	5ft	7,6ft	10,1ft	15,1ft	20,2ft	25,2ft	30,3ft	40,4ft	50,5ft

LINEAR DISTRIBUTION DIAGRAM

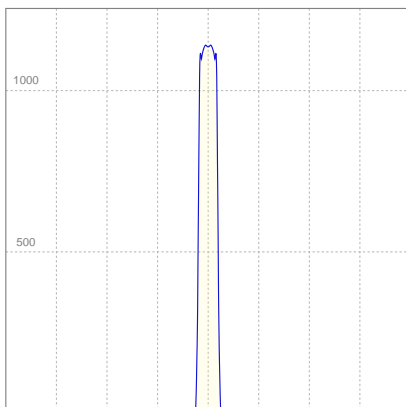

ELECTRICAL SPECIFICATIONS

Input voltage	Input current	Input power	Effeciency
224V	0,072A	13,9W	6lm/W

Power FC
0,86

ISO CANDELA DIAGRAM

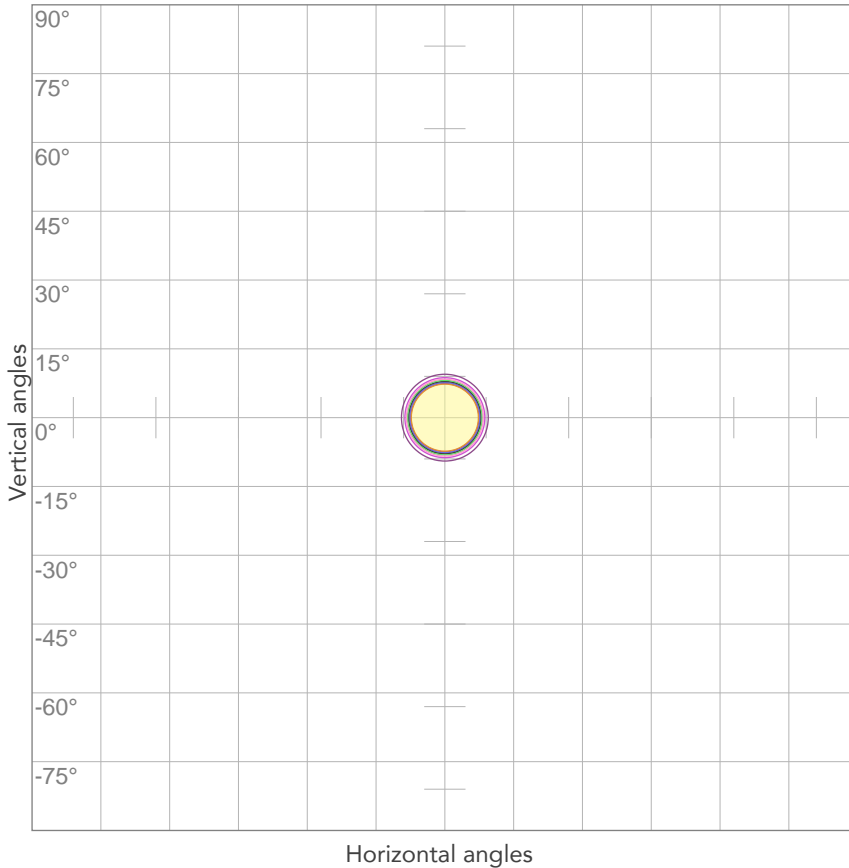

Conditions:
 Number of c-planes: 2
 Candela at center: 1136 cd

ISO LUX DIAGRAM

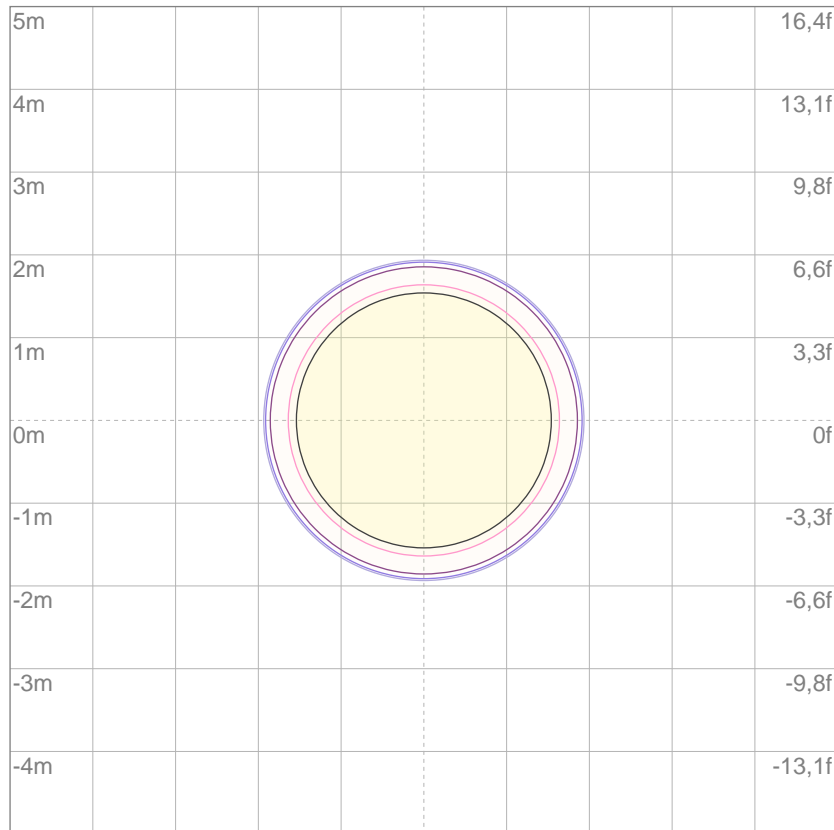

Conditions:
 Number of c-planes: 2
 Lux at center: 11,4 lx

Lux distribution on a surface when lamp is mounted at 10 meters from the surface.

Mounting height: 10 meters (33 feet)



Total lumen output:

142 lm

Peak candela output:

455 cd

PRODUCT NAME:

ECLDISPLAYFC

MEASUREMENT CONDITIONS:

Beam angle:

Profile Max Zoom

Target:

Green

Operator:

Paolo Carvone

Date and time:

03/12/2020 17:00:47

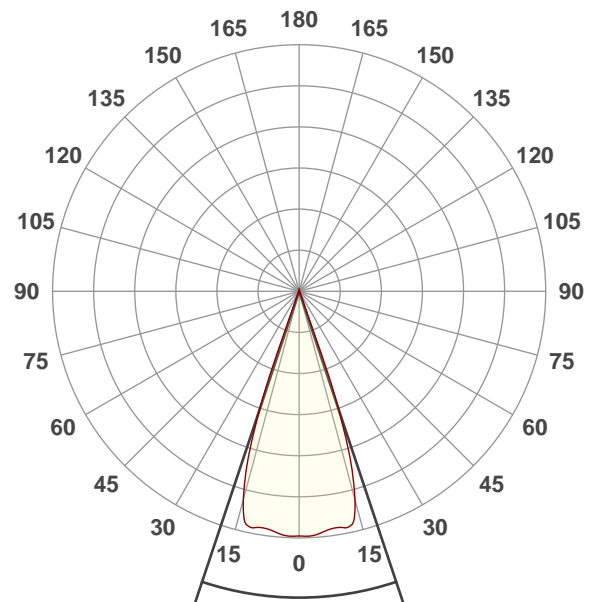

Beam angle 50%: 36,9°

Field angle 10%: 41,3°

Cut off angle 2.5%: 43,7°

Spectra

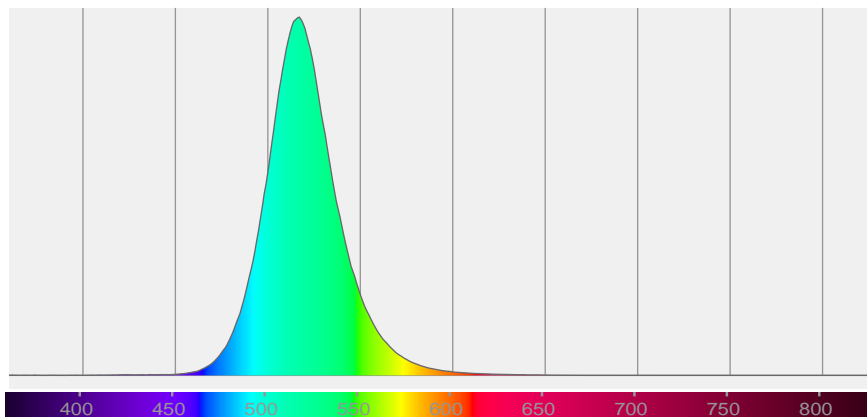

BEAM DETAILS



Beam angle 50%	Field angle 10%	Cut off angle 2,5%	Intensity ratio in 120° cone	Intensity ratio in 90° cone
36,9°	41,3°	43,7°	100,0%	100,0%

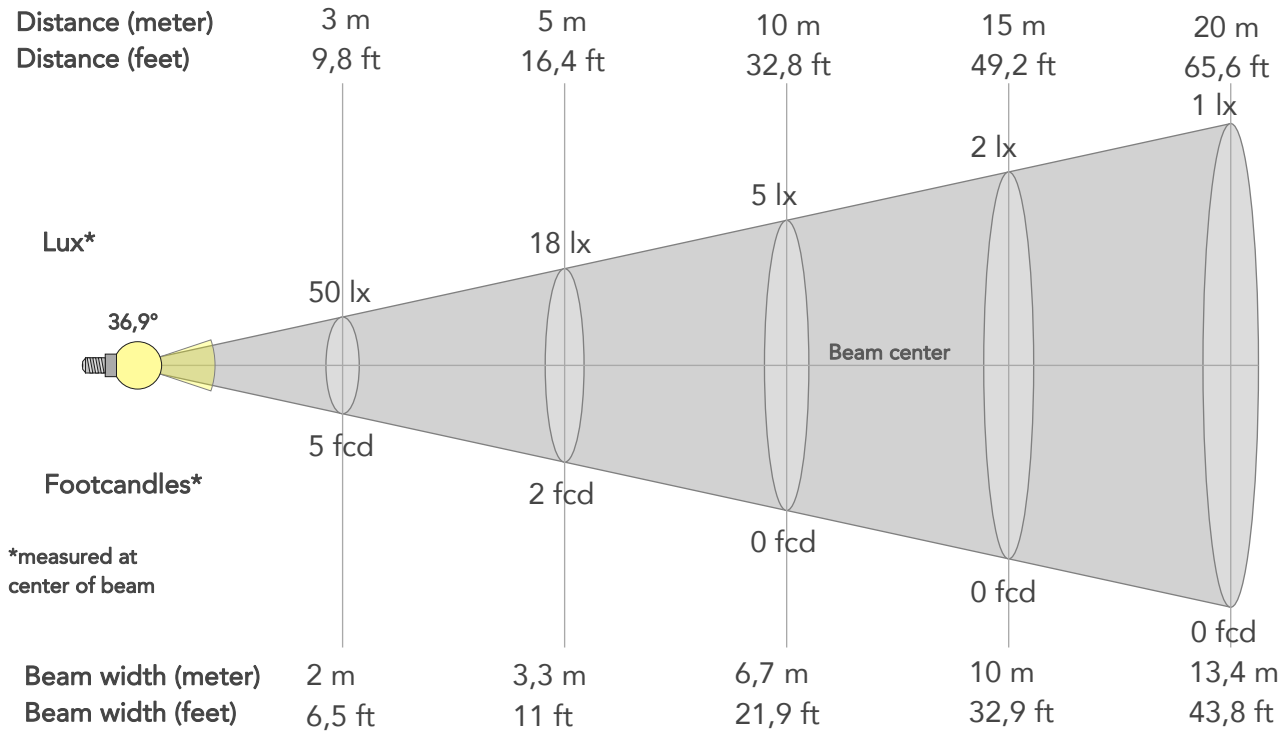

BEAM INTENSITIES AND WIDTHS

Distance	1m	2m	3m	4m	5m	7,5m	10m	15m	20m	25m	30m	40m	50m
Distance	3,3ft	6,6ft	9,8ft	13,1ft	16,4ft	24,6ft	32,8ft	49,2ft	65,6ft	82ft	98,4ft	131,2ft	164ft
Lux	454lx	114lx	50lx	28lx	18lx	8lx	5lx	2lx	1lx	1lx	1lx	0lx	0lx
Footcand.	42fcd	11fcd	5fcd	3fcd	2fcd	1fcd	0fcd	0fcd	0fcd	0fcd	0fcd	0fcd	0fcd
Beam wid.	0,7m	1,3m	2m	2,7m	3,3m	5m	6,7m	10m	13,4m	16,7m	20m	26,7m	33,4m
Beam wid.	2,2ft	4,4ft	6,5ft	8,8ft	11ft	16,4ft	21,9ft	32,9ft	43,8ft	54,8ft	65,7ft	87,7ft	109,6ft

LINEAR DISTRIBUTION DIAGRAM

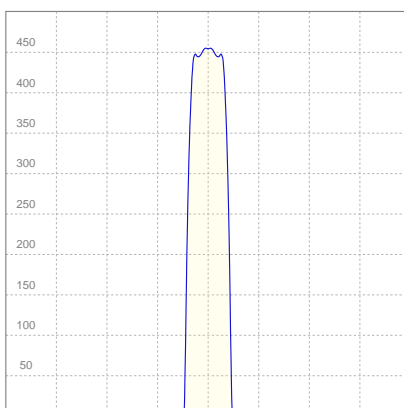

ELECTRICAL SPECIFICATIONS

Input voltage	Input current	Input power	Effeciency
224V	0,097A	19,3W	7lm/W

Power FC
0,89

ISO CANDELA DIAGRAM

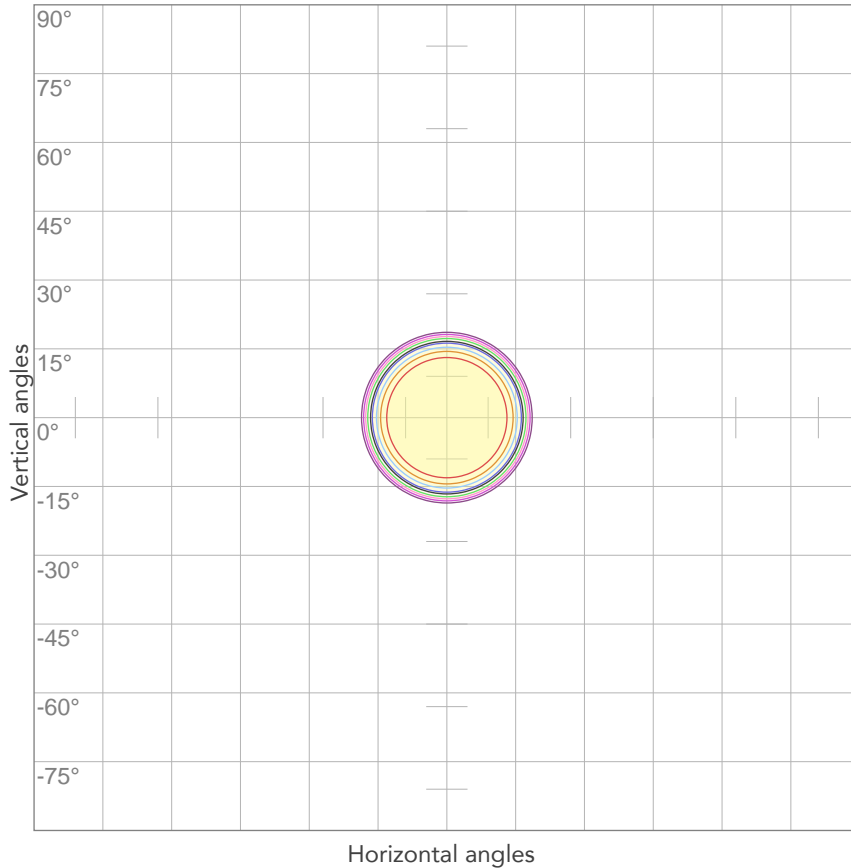

10%	45 cd
20%	91 cd
30%	136 cd
40%	182 cd
50%	227 cd
60%	273 cd
70%	318 cd
80%	364 cd

Conditions:

Number of c-planes: 2
Candela at center: 454 cd

ISO LUX DIAGRAM

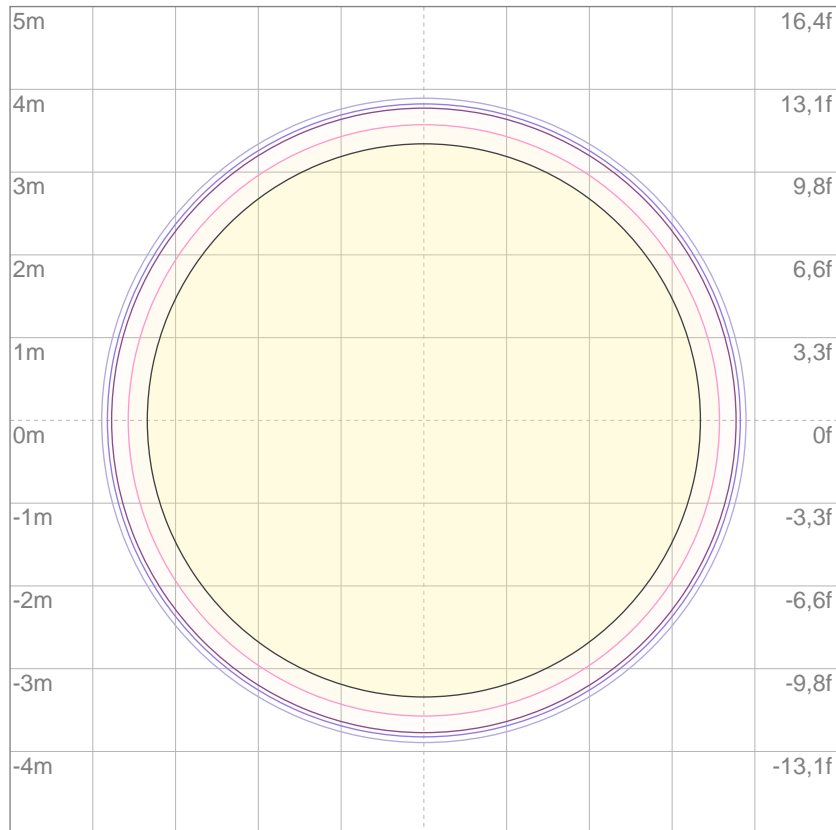

3%	0,136 lx
5%	0,227 lx
10%	0,454 lx
30%	1,36 lx
50%	2,27 lx

Conditions:

Number of c-planes: 2
Lux at center: 4,54 lx

Lux distribution on a surface when lamp is mounted at 10 meters from the surface.

Mounting height: 10 meters (33 feet)



Total lumen output:

158 lm

Peak candela output:

2101 cd

PRODUCT NAME:

ECLDISPLAYFC

MEASUREMENT CONDITIONS:

Beam angle:

Profile Min Zoom

Target:

Green

Operator:

Paolo Carvone

Date and time:

03/12/2020 16:52:02

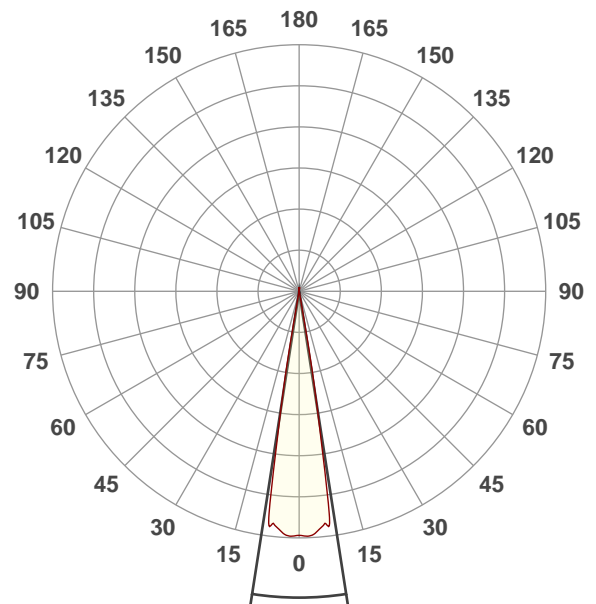

Beam angle 50%: 17,7°

Field angle 10%: 20,6°

Cut off angle 2.5%: 21,3°

Spectra

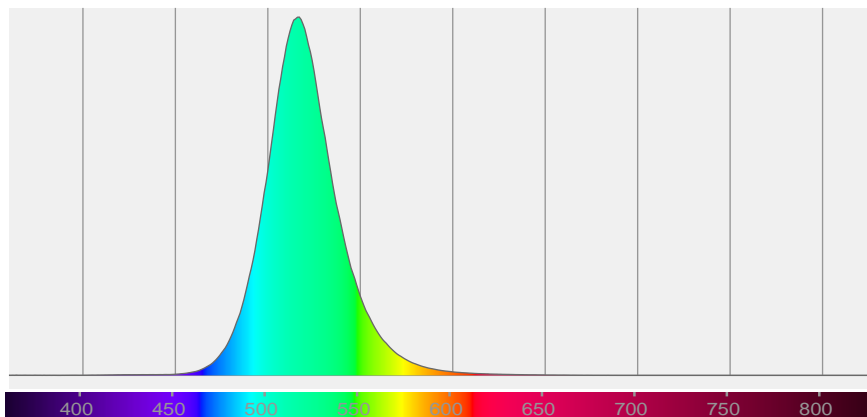

BEAM DETAILS



Beam angle 50%	Field angle 10%	Cut off angle 2,5%	Intensity ratio in 120° cone	Intensity ratio in 90° cone
17,7°	20,6°	21,3°	100,0%	100,0%

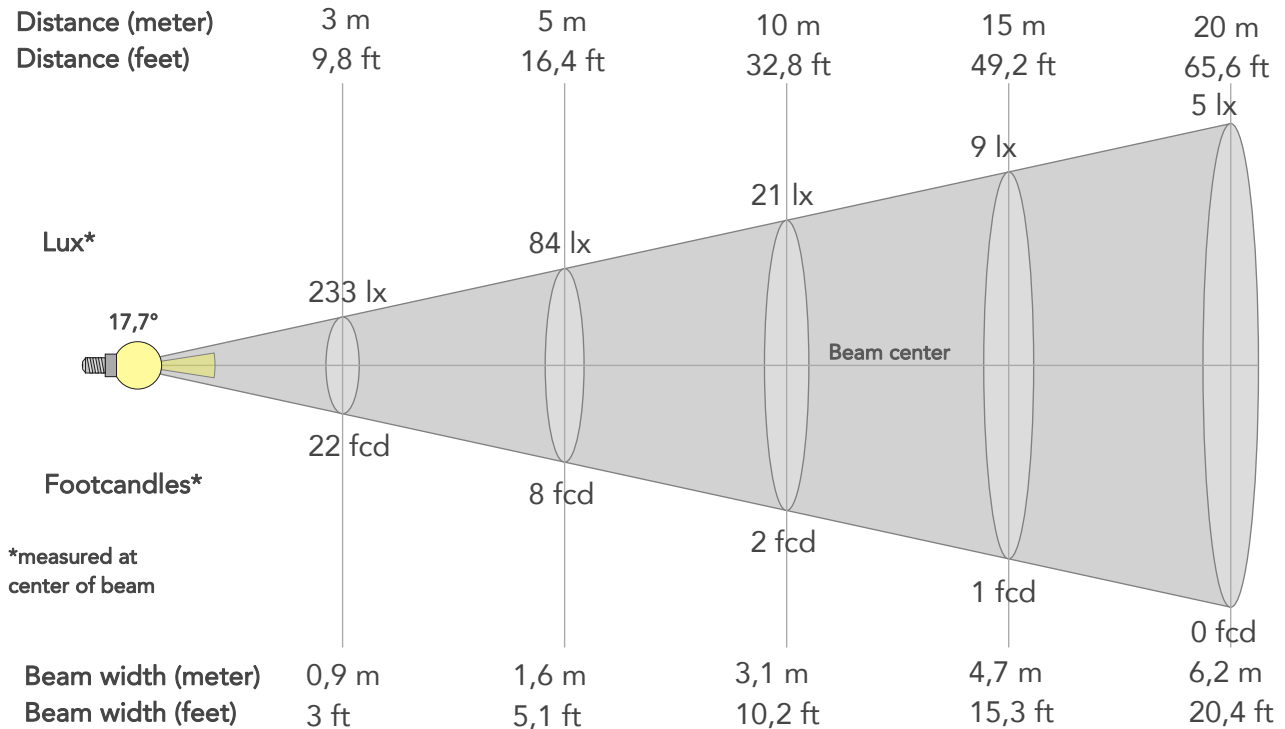

BEAM INTENSITIES AND WIDTHS

Distance	1m	2m	3m	4m	5m	7,5m	10m	15m	20m	25m	30m	40m	50m
Distance	3,3ft	6,6ft	9,8ft	13,1ft	16,4ft	24,6ft	32,8ft	49,2ft	65,6ft	82ft	98,4ft	131,2ft	164ft
Lux	2093lx	523lx	233lx	131lx	84lx	37lx	21lx	9lx	5lx	3lx	2lx	1lx	1lx
Footcand.	194fcd	49fcd	22fcd	12fcd	8fcd	3fcd	2fcd	1fcd	0fcd	0fcd	0fcd	0fcd	0fcd
Beam wid.	0,3m	0,6m	0,9m	1,2m	1,6m	2,3m	3,1m	4,7m	6,2m	7,8m	9,3m	12,4m	15,5m
Beam wid.	1ft	2,1ft	3ft	4,1ft	5,1ft	7,6ft	10,2ft	15,3ft	20,4ft	25,5ft	30,6ft	40,8ft	51ft

LINEAR DISTRIBUTION DIAGRAM

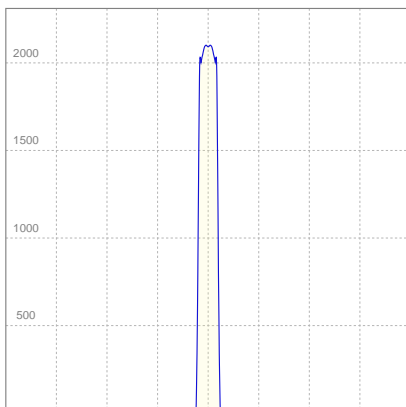

ELECTRICAL SPECIFICATIONS

Input voltage	Input current	Input power	Effeciency
224V	0,097A	19,4W	8lm/W

Power FC
0,89

ISO CANDELA DIAGRAM

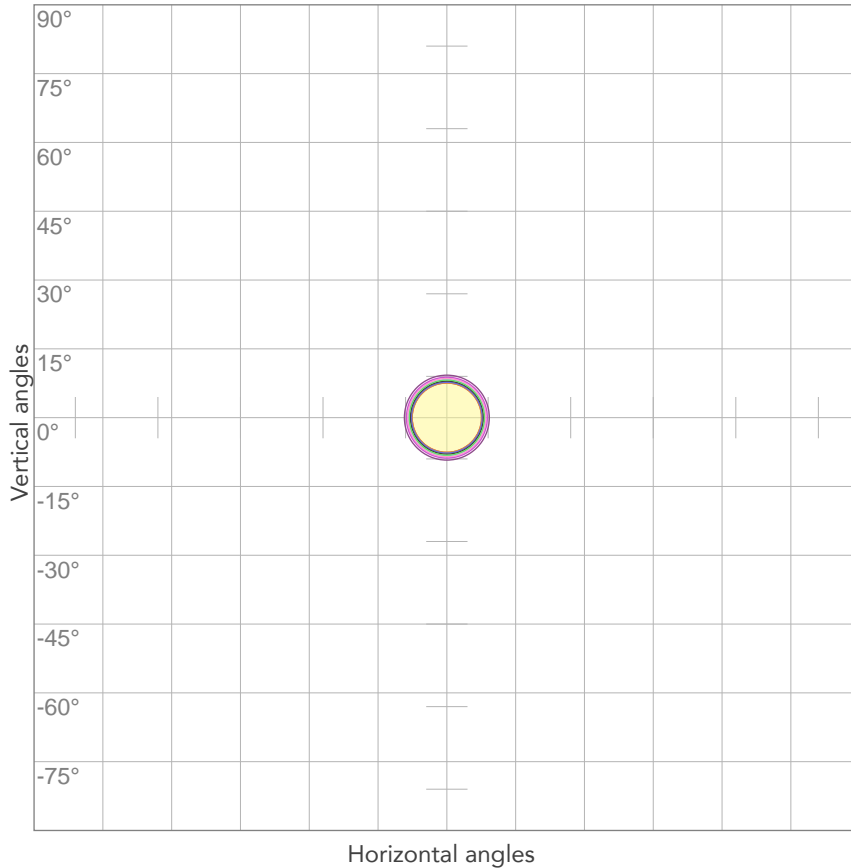

10%	209 cd
20%	419 cd
30%	628 cd
40%	837 cd
50%	1047 cd
60%	1256 cd
70%	1465 cd
80%	1675 cd

Conditions:

Number of c-planes: 2

Candela at center: 2093 cd

ISO LUX DIAGRAM

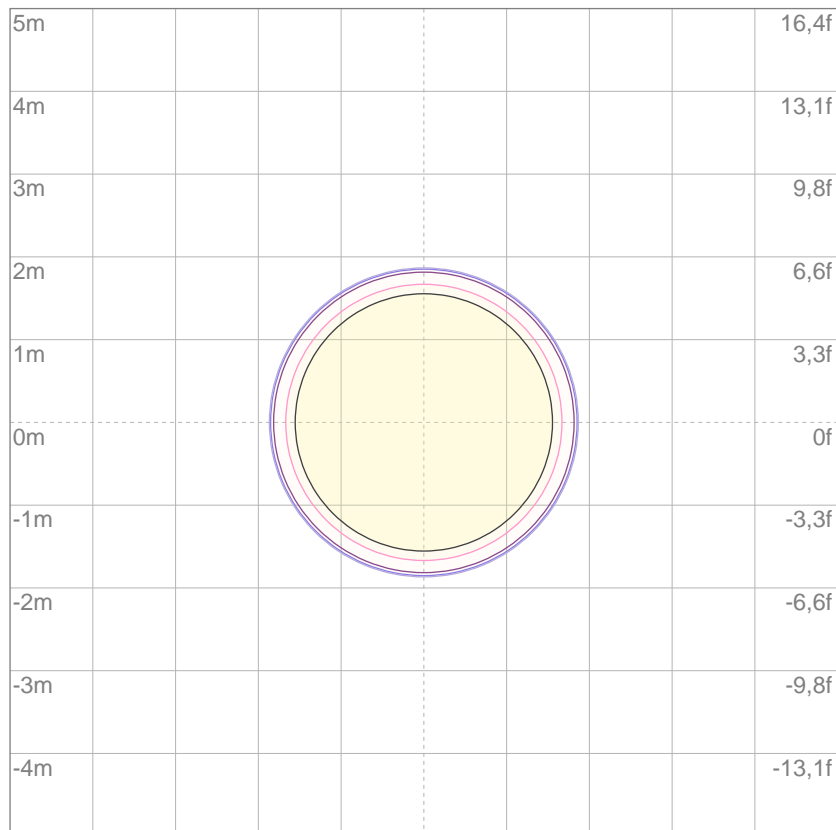

3%	0,628 lx
5%	1,05 lx
10%	2,09 lx
30%	6,28 lx
50%	10,5 lx

Conditions:

Number of c-planes: 2

Lux at center: 20,9 lx

Lux distribution on a surface when lamp is mounted at 10 meters from the surface.

Mounting height: 10 meters (33 feet)



Total lumen output:

37,2 lm

Peak candela output:

117 cd

PRODUCT NAME:

ECLDISPLAYFC

MEASURAMENT CONDITIONS:

Beam angle:

Profile Max Zoom

Target:

Blue

Operator:

Paolo Carvone

Date and time:

03/12/2020 17:02:40

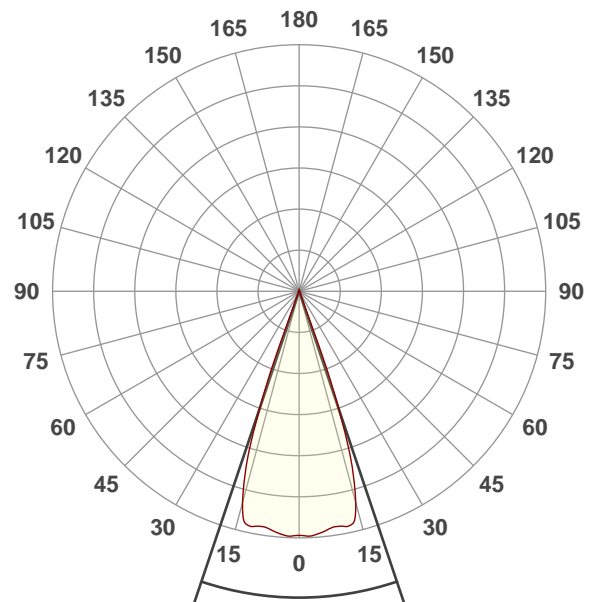

Beam angle 50%: 37,2°

Field angle 10%: 41,9°

Cut off angle 2.5%: 44,1°

Spectra

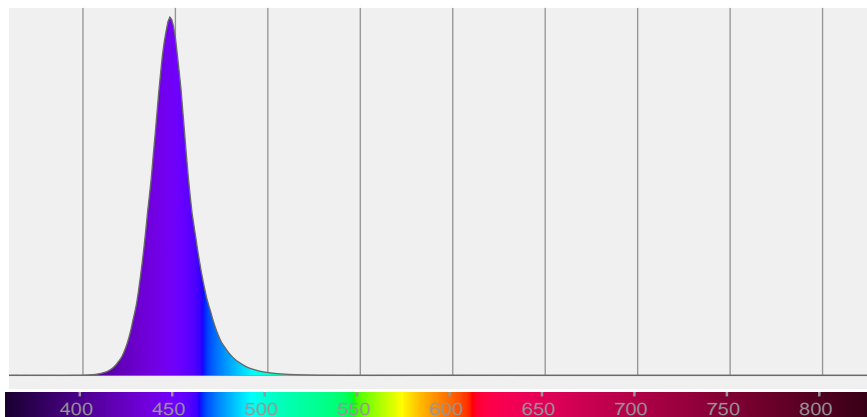

BEAM DETAILS



Beam angle 50%	Field angle 10%	Cut off angle 2,5%	Intensity ratio in 120° cone	Intensity ratio in 90° cone
37,2°	41,9°	44,1°	99,9%	99,9%

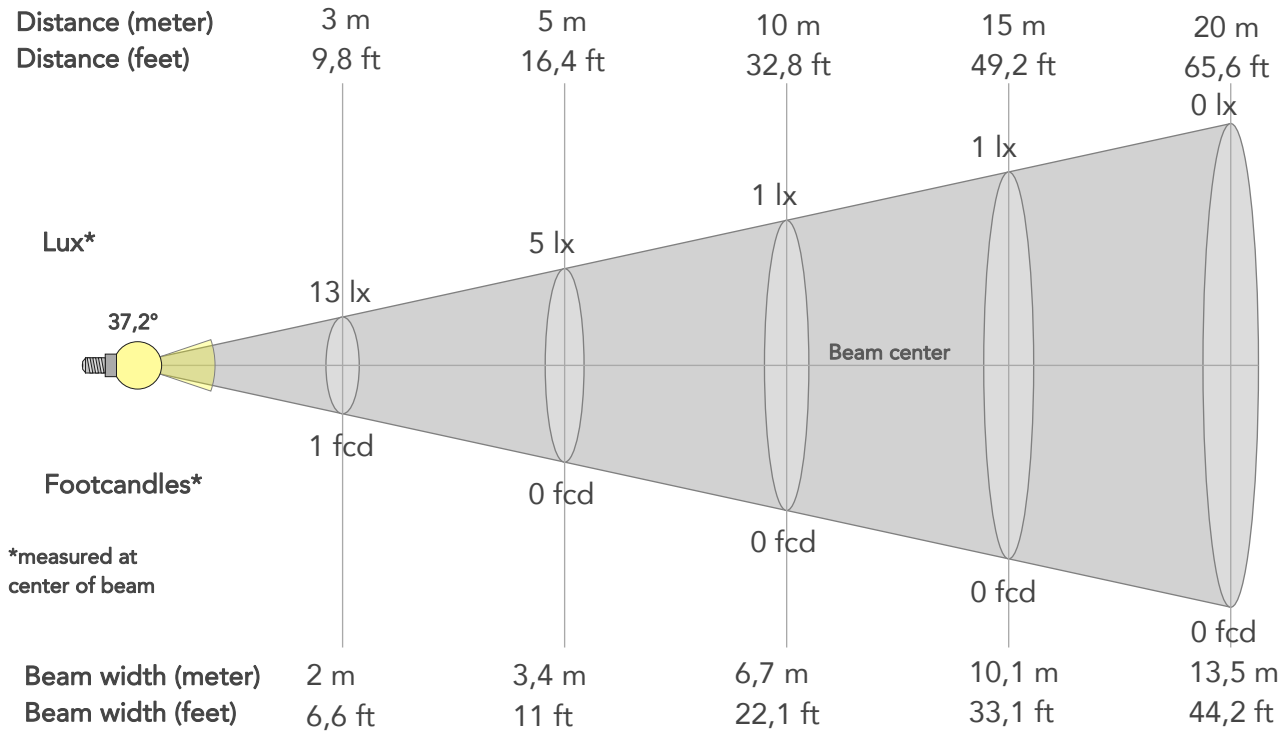

BEAM INTENSITIES AND WIDTHS

Distance	1m	2m	3m	4m	5m	7,5m	10m	15m	20m	25m	30m	40m	50m
Distance	3,3ft	6,6ft	9,8ft	13,1ft	16,4ft	24,6ft	32,8ft	49,2ft	65,6ft	82ft	98,4ft	131,2ft	164ft
Lux	117lx	29lx	13lx	7lx	5lx	2lx	1lx	1lx	0lx	0lx	0lx	0lx	0lx
Footcand.	11fcd	3fcd	1fcd	1fcd	0fcd	0fcd	0fcd	0fcd	0fcd	0fcd	0fcd	0fcd	0fcd
Beam wid.	0,7m	1,3m	2m	2,7m	3,4m	5,1m	6,7m	10,1m	13,5m	16,8m	20,2m	26,9m	33,7m
Beam wid.	2,2ft	4,4ft	6,6ft	8,8ft	11ft	16,6ft	22,1ft	33,1ft	44,2ft	55,2ft	66,3ft	88,4ft	110,4ft

LINEAR DISTRIBUTION DIAGRAM

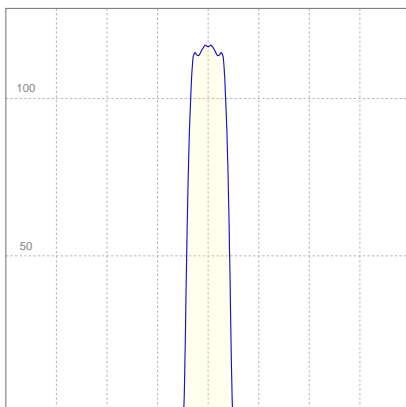

ELECTRICAL SPECIFICATIONS

Input voltage	Input current	Input power	Effeciency
225V	0,091A	18,0W	2lm/W

Power FC
0,88

ISO CANDELA DIAGRAM

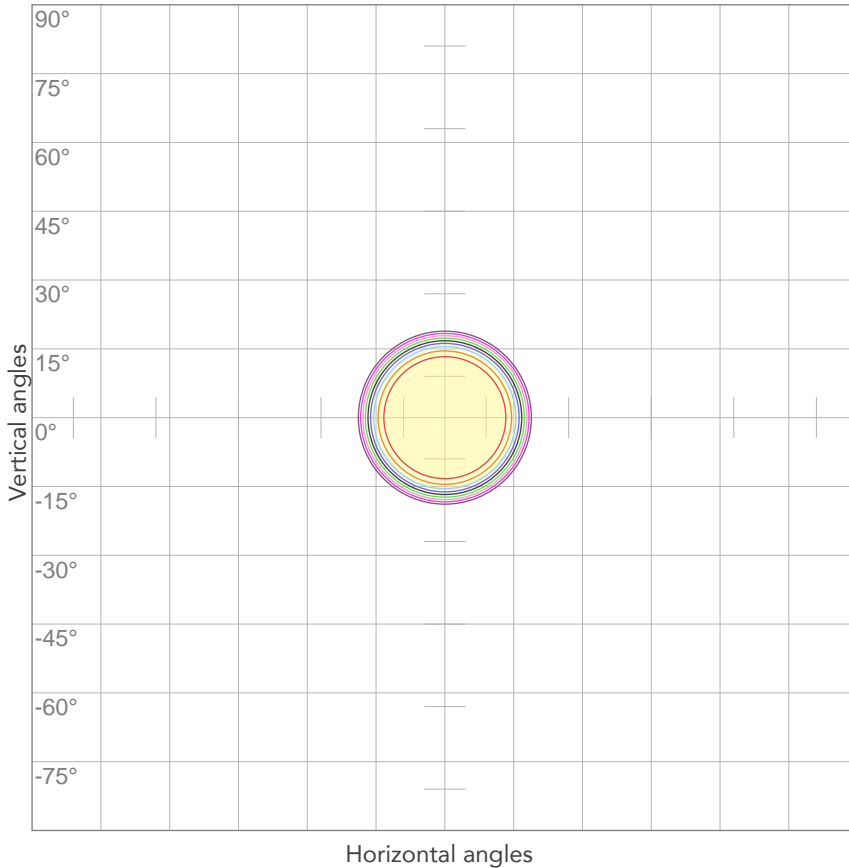

10%	12 cd
20%	23 cd
30%	35 cd
40%	47 cd
50%	58 cd
60%	70 cd
70%	82 cd
80%	93 cd

Conditions:

Number of c-planes: 2

Candela at center: 117 cd

ISO LUX DIAGRAM

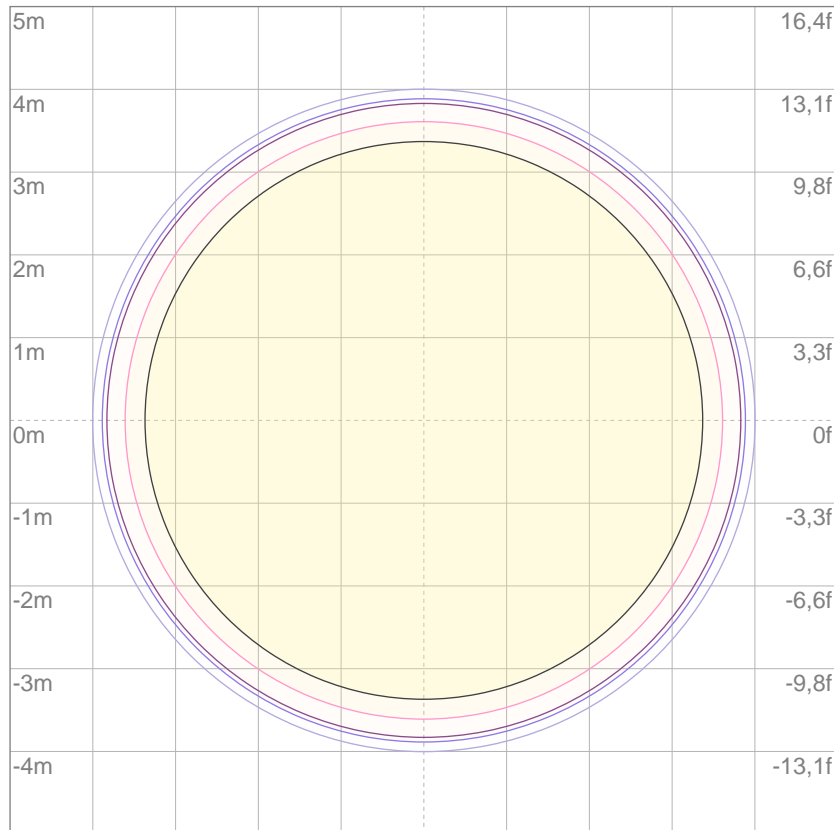

Mounting height: 10 meters (33 feet)

3%	35,0m lx
5%	58,3m lx
10%	0,117 lx
30%	0,350 lx
50%	0,583 lx

Conditions:

Number of c-planes: 2

Lux at center: 1,17 lx

Lux distribution on a surface when lamp is mounted at 10 meters from the surface.



Total lumen output:

41,2 lm

Peak candela output:

546 cd

PRODUCT NAME:

ECLDISPLAYFC

MEASUREMENT CONDITIONS:

Beam angle:

Profile Min Zoom

Target:

Blue

Operator:

Paolo Carvone

Date and time:

03/12/2020 16:53:29

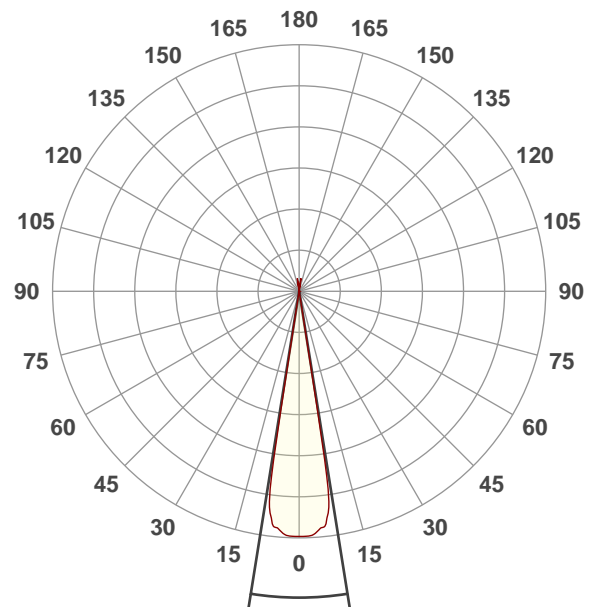

Beam angle 50%: 18,2°

Field angle 10%: 20°

Cut off angle 2.5%: 20,3°

Spectra

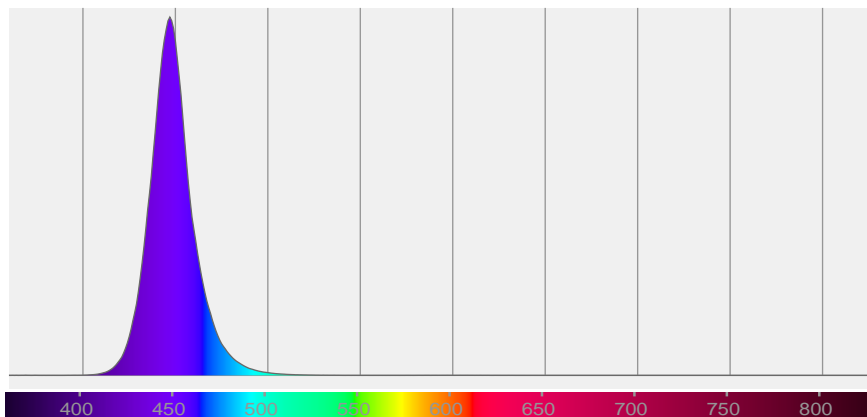

BEAM DETAILS



Beam angle 50%	Field angle 10%	Cut off angle 2,5%	Intensity ratio in 120° cone	Intensity ratio in 90° cone
18,2°	20°	20,3°	100,0%	100,0%

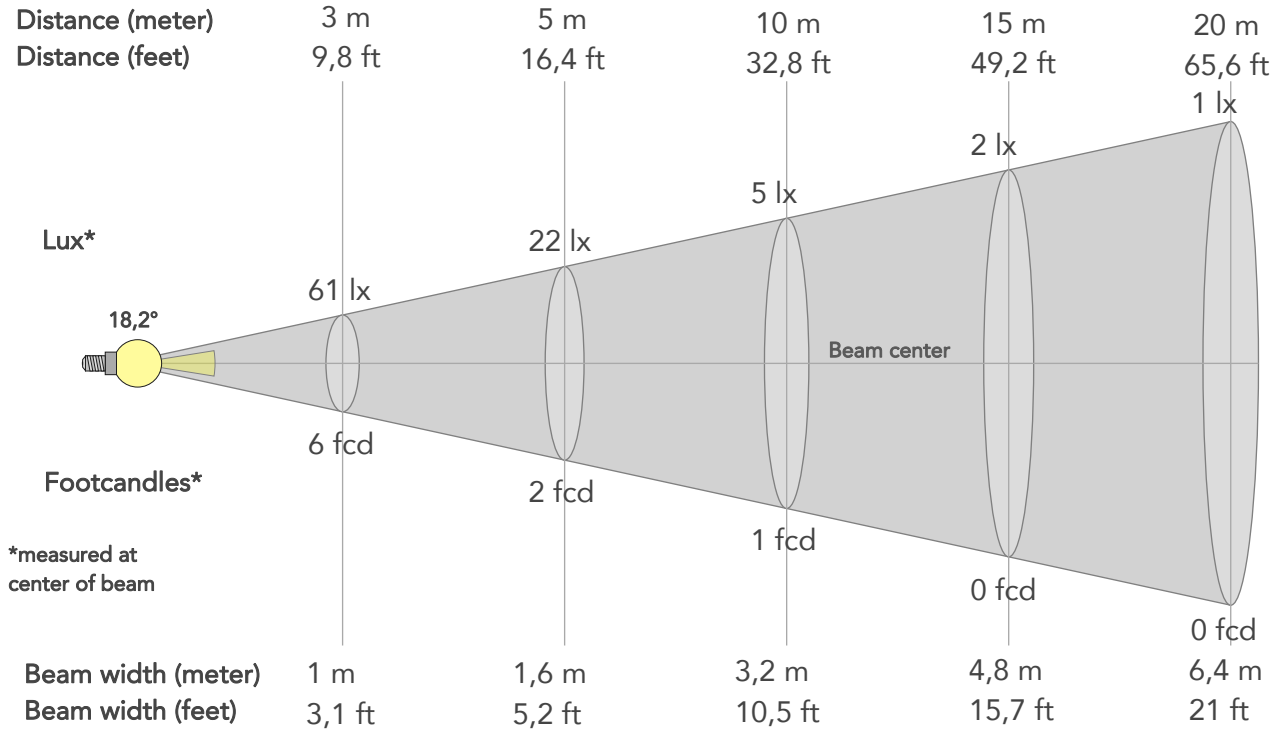

BEAM INTENSITIES AND WIDTHS

Distance	1m	2m	3m	4m	5m	7,5m	10m	15m	20m	25m	30m	40m	50m
Distance	3,3ft	6,6ft	9,8ft	13,1ft	16,4ft	24,6ft	32,8ft	49,2ft	65,6ft	82ft	98,4ft	131,2ft	164ft
Lux	546lx	136lx	61lx	34lx	22lx	10lx	5lx	2lx	1lx	1lx	1lx	0lx	0lx
Footcand.	51fcd	13fcd	6fcd	3fcd	2fcd	1fcd	1fcd	0fcd	0fcd	0fcd	0fcd	0fcd	0fcd
Beam wid.	0,3m	0,6m	1m	1,3m	1,6m	2,4m	3,2m	4,8m	6,4m	8m	9,6m	12,8m	16m
Beam wid.	1,1ft	2,1ft	3,1ft	4,2ft	5,2ft	7,9ft	10,5ft	15,7ft	21ft	26,2ft	31,5ft	41,9ft	52,4ft

LINEAR DISTRIBUTION DIAGRAM

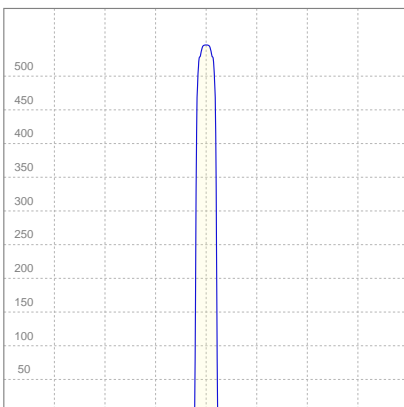

ELECTRICAL SPECIFICATIONS

Input voltage	Input current	Input power	Effeciency
224V	0,091A	18,1W	2lm/W

Power FC
0,89

ISO CANDELA DIAGRAM

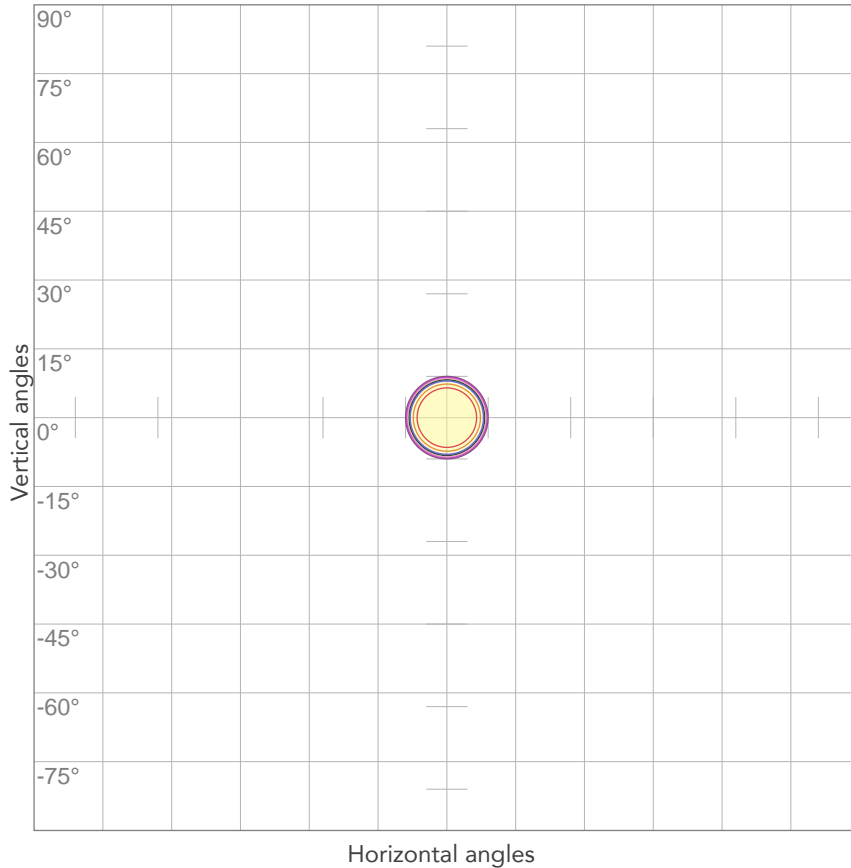

10%	55 cd
20%	109 cd
30%	164 cd
40%	218 cd
50%	273 cd
60%	328 cd
70%	382 cd
80%	437 cd

Conditions:

Number of c-planes: 2

Candela at center: 546 cd

ISO LUX DIAGRAM

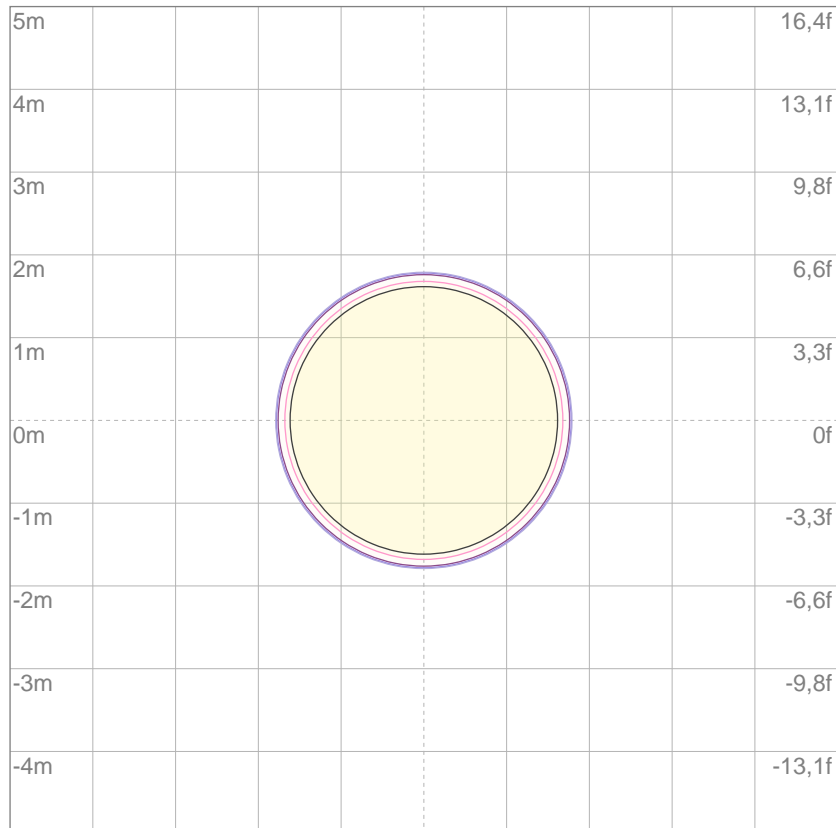

3%	0,164 lx
5%	0,273 lx
10%	0,546 lx
30%	1,64 lx
50%	2,73 lx

Conditions:

Number of c-planes: 2

Lux at center: 5,46 lx

Lux distribution on a surface when lamp is mounted at 10 meters from the surface.

Mounting height: 10 meters (33 feet)



Total lumen output:

203 lm

Peak candela output:

653 cd

PRODUCT NAME:

ECLDISPLAYFC

MEASUREMENT CONDITIONS:

Beam angle:

Profile Max Zoom

Target:

White

Operator:

Paolo Carvone

Date and time:

03/12/2020 17:04:23

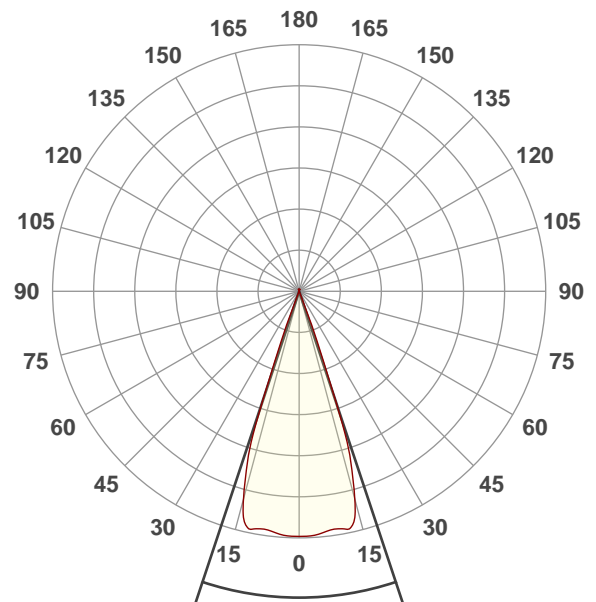

Beam angle 50%: 36,8°

Field angle 10%: 41,7°

Cut off angle 2.5%: 43°

Spectra

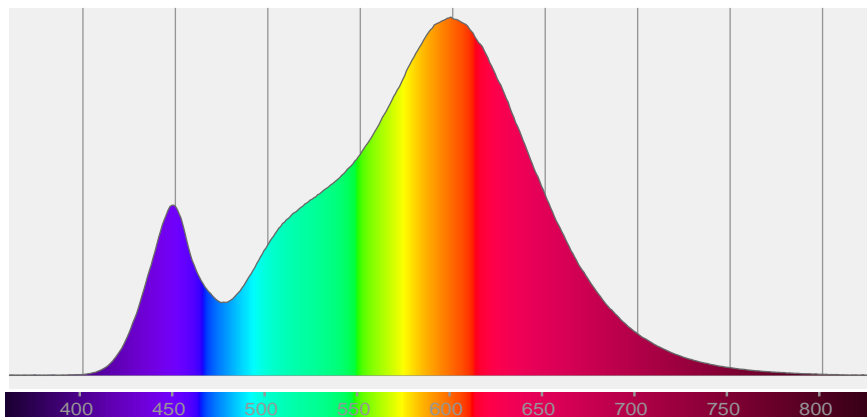

BEAM DETAILS



Beam angle 50%	Field angle 10%	Cut off angle 2,5%	Intensity ratio in 120° cone	Intensity ratio in 90° cone
36,8°	41,7°	43°	100,0%	100,0%

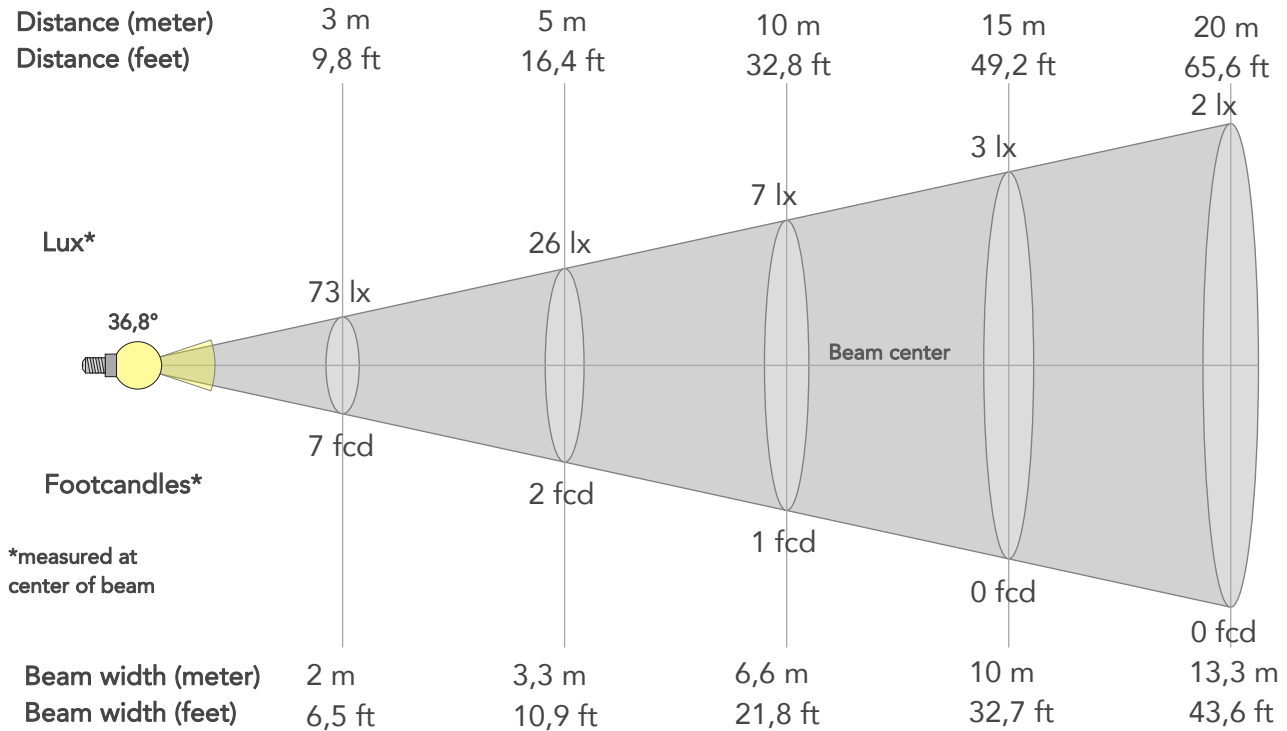

BEAM INTENSITIES AND WIDTHS

Distance	1m	2m	3m	4m	5m	7,5m	10m	15m	20m	25m	30m	40m	50m
Distance	3,3ft	6,6ft	9,8ft	13,1ft	16,4ft	24,6ft	32,8ft	49,2ft	65,6ft	82ft	98,4ft	131,2ft	164ft
Lux	653lx	163lx	73lx	41lx	26lx	12lx	7lx	3lx	2lx	1lx	1lx	0lx	0lx
Footcand.	61fcd	15fcd	7fcd	4fcd	2fcd	1fcd	1fcd	0fcd	0fcd	0fcd	0fcd	0fcd	0fcd
Beam wid.	0,7m	1,3m	2m	2,7m	3,3m	5m	6,6m	10m	13,3m	16,6m	19,9m	26,6m	33,2m
Beam wid.	2,2ft	4,4ft	6,5ft	8,7ft	10,9ft	16,4ft	21,8ft	32,7ft	43,6ft	54,5ft	65,4ft	87,2ft	109,1ft

LINEAR DISTRIBUTION DIAGRAM

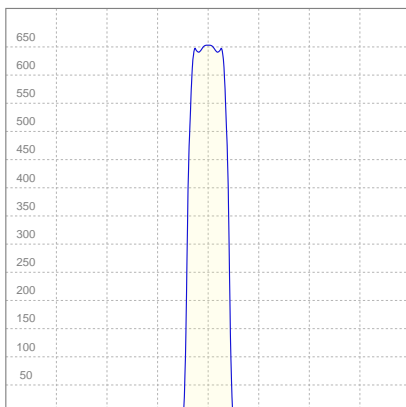

ELECTRICAL SPECIFICATIONS

Input voltage	Input current	Input power	Effeciency
224V	0,096A	19,2W	11lm/W

Power FC
0,89

ISO CANDELA DIAGRAM

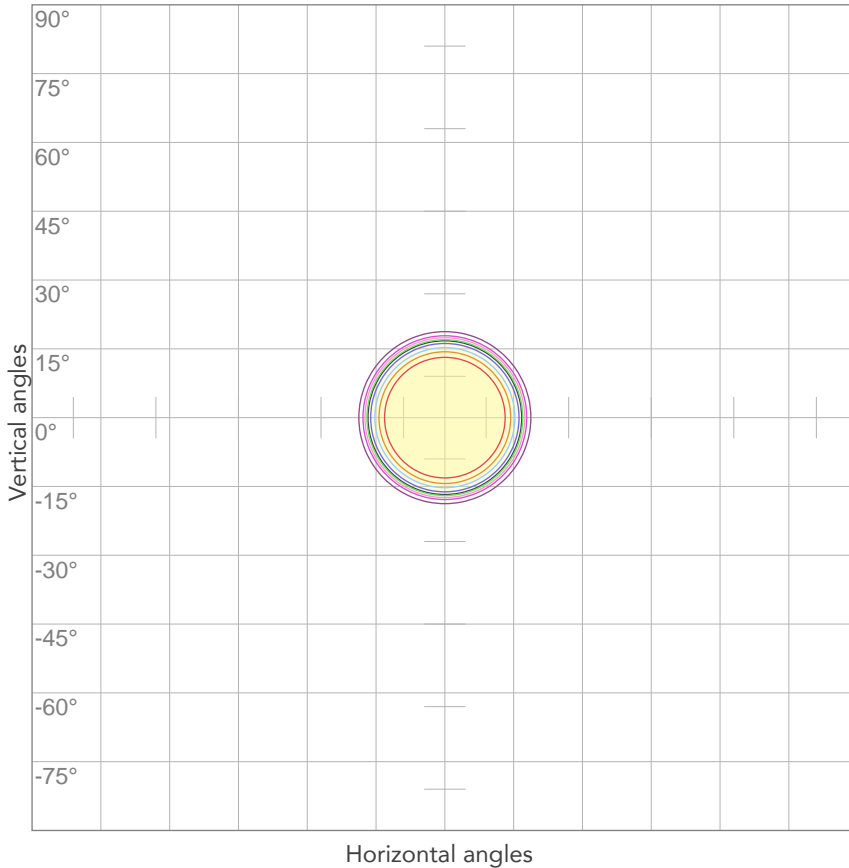

10%	65 cd
20%	131 cd
30%	196 cd
40%	261 cd
50%	326 cd
60%	392 cd
70%	457 cd
80%	522 cd

Conditions:

Number of c-planes: 2
Candela at center: 653 cd

ISO LUX DIAGRAM

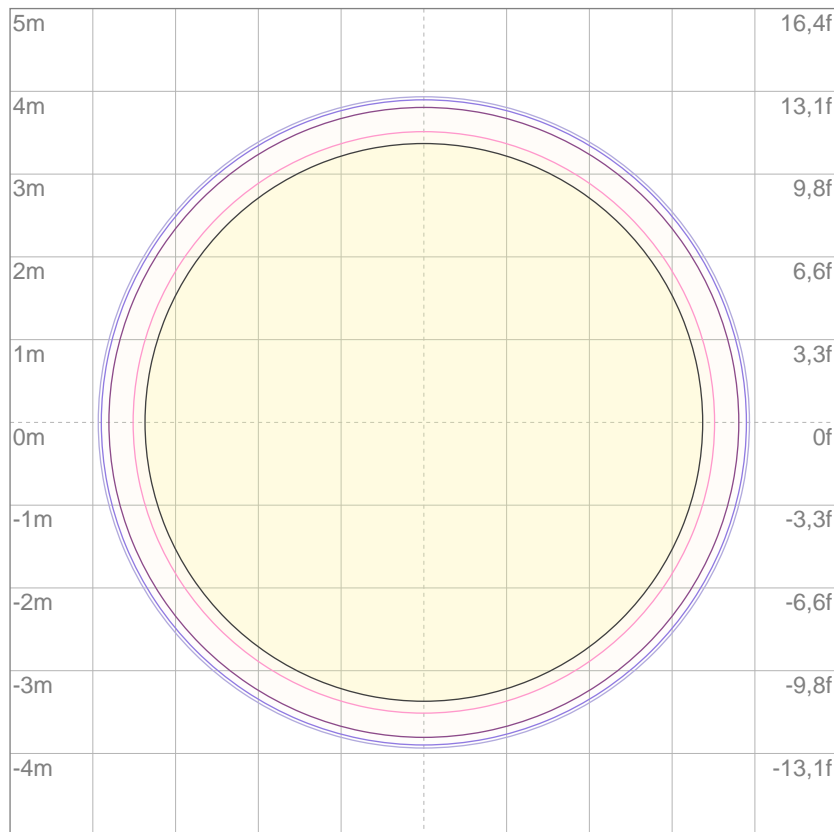

Mounting height: 10 meters (33 feet)

3%	0,196 lx
5%	0,326 lx
10%	0,653 lx
30%	1,96 lx
50%	3,26 lx

Conditions:

Number of c-planes: 2
Lux at center: 6,53 lx

Lux distribution on a surface when lamp is mounted at 10 meters from the surface.



Total lumen output:

225 lm

Peak candela output:

3004 cd

PRODUCT NAME:

ECLDISPLAYFC

MEASURAMENT CONDITIONS:

Beam angle:

Profile Min Zoom

Target:

White

Operator:

Paolo Carvone

Date and time:

03/12/2020 16:55:16

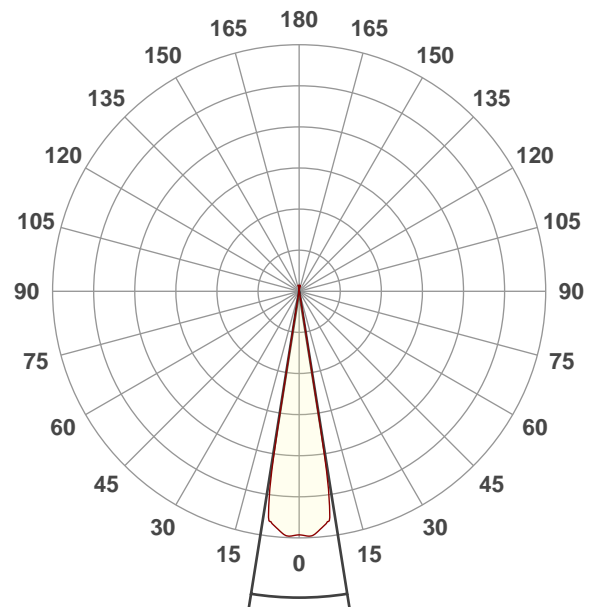

Beam angle 50%: 18,1°

Field angle 10%: 19,2°

Cut off angle 2.5%: 20,4°

Spectra

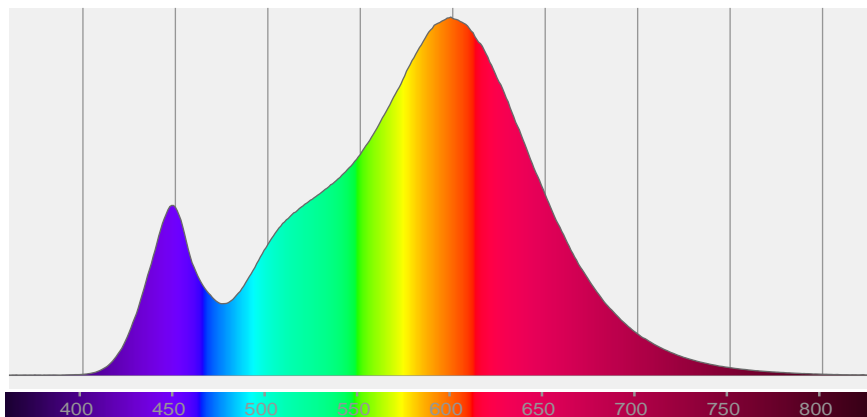

Beam angle 50%	Field angle 10%	Cut off angle 2,5%	Intensity ratio in 120° cone	Intensity ratio in 90° cone
18,1°	19,2°	20,4°	100,0%	100,0%

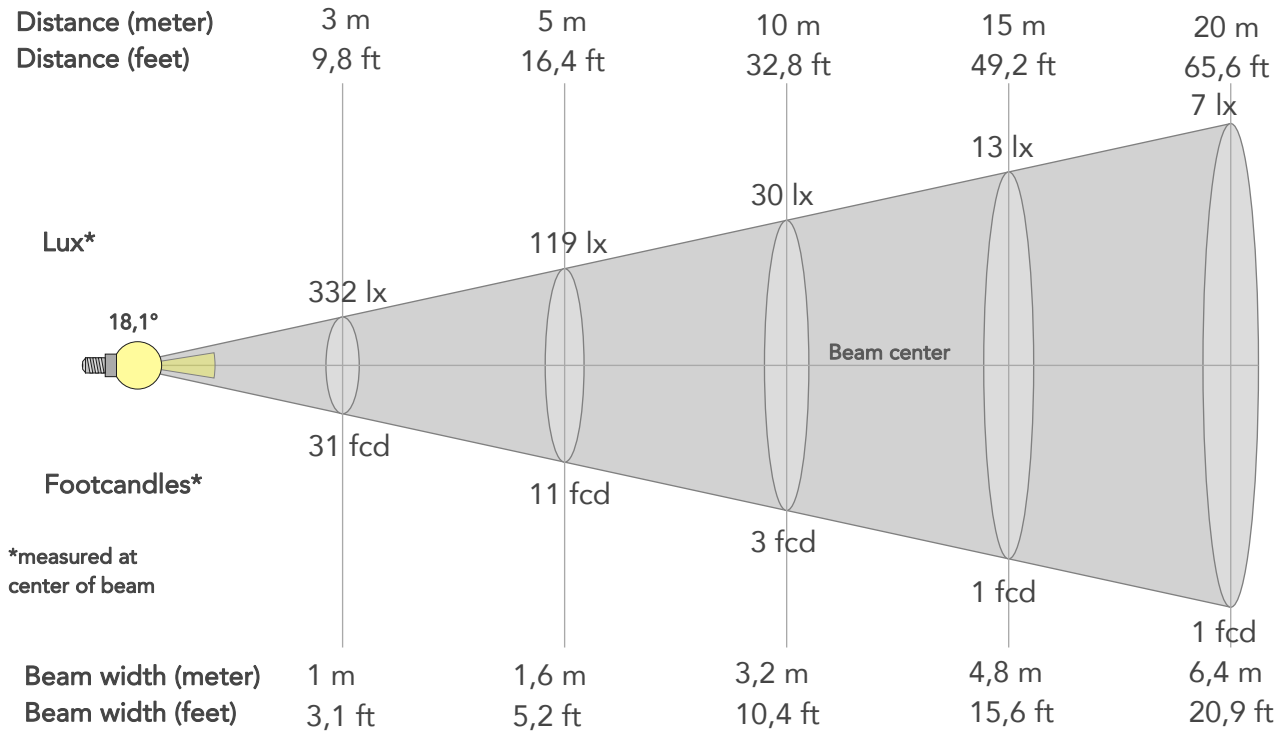

BEAM INTENSITIES AND WIDTHS

Distance	1m	2m	3m	4m	5m	7,5m	10m	15m	20m	25m	30m	40m	50m
Distance	3,3ft	6,6ft	9,8ft	13,1ft	16,4ft	24,6ft	32,8ft	49,2ft	65,6ft	82ft	98,4ft	131,2ft	164ft
Lux	2987lx	747lx	332lx	187lx	119lx	53lx	30lx	13lx	7lx	5lx	3lx	2lx	1lx
Footcand.	277fcd	69fcd	31fcd	17fcd	11fcd	5fcd	3fcd	1fcd	1fcd	0fcd	0fcd	0fcd	0fcd
Beam wid.	0,3m	0,6m	1m	1,3m	1,6m	2,4m	3,2m	4,8m	6,4m	7,9m	9,5m	12,7m	15,9m
Beam wid.	1ft	2,1ft	3,1ft	4,2ft	5,2ft	7,8ft	10,4ft	15,6ft	20,9ft	26,1ft	31,3ft	41,7ft	52,1ft

LINEAR DISTRIBUTION DIAGRAM

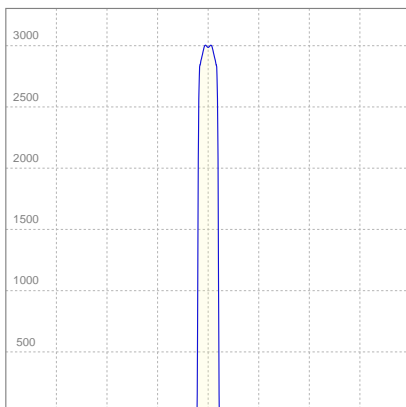

ELECTRICAL SPECIFICATIONS

Input voltage	Input current	Input power	Effeciency
224V	0,097A	19,3W	12lm/W

Power FC
0,89

ISO CANDELA DIAGRAM

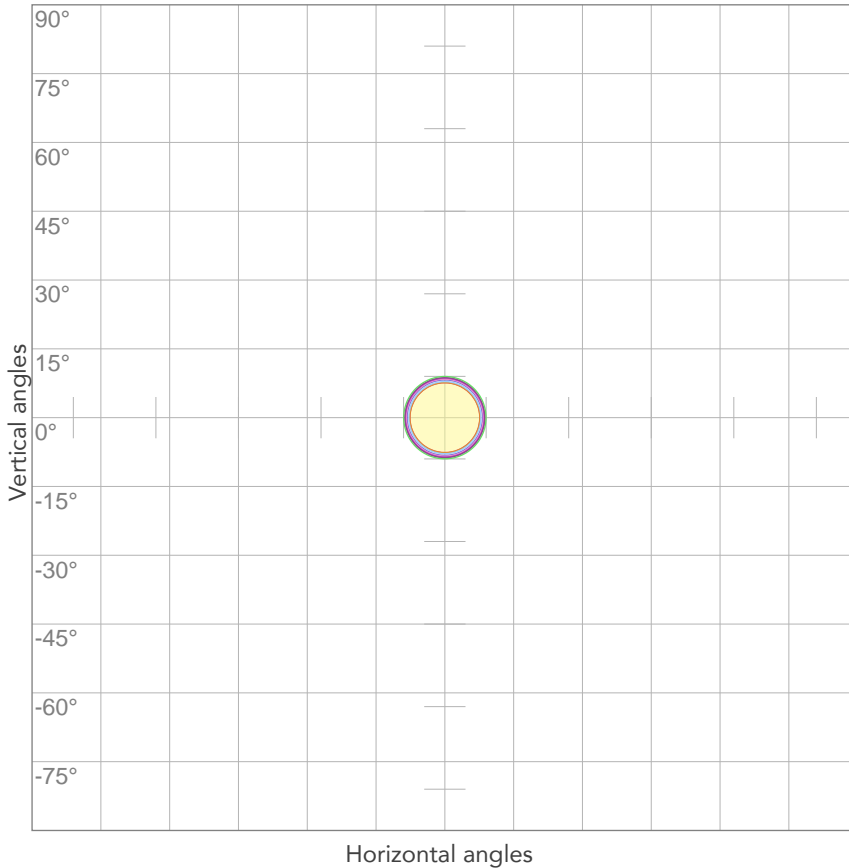

10%	299 cd
20%	597 cd
30%	896 cd
40%	1195 cd
50%	1493 cd
60%	1792 cd
70%	2091 cd
80%	2389 cd

Conditions:

Number of c-planes: 2

Candela at center: 2987 cd

ISO LUX DIAGRAM

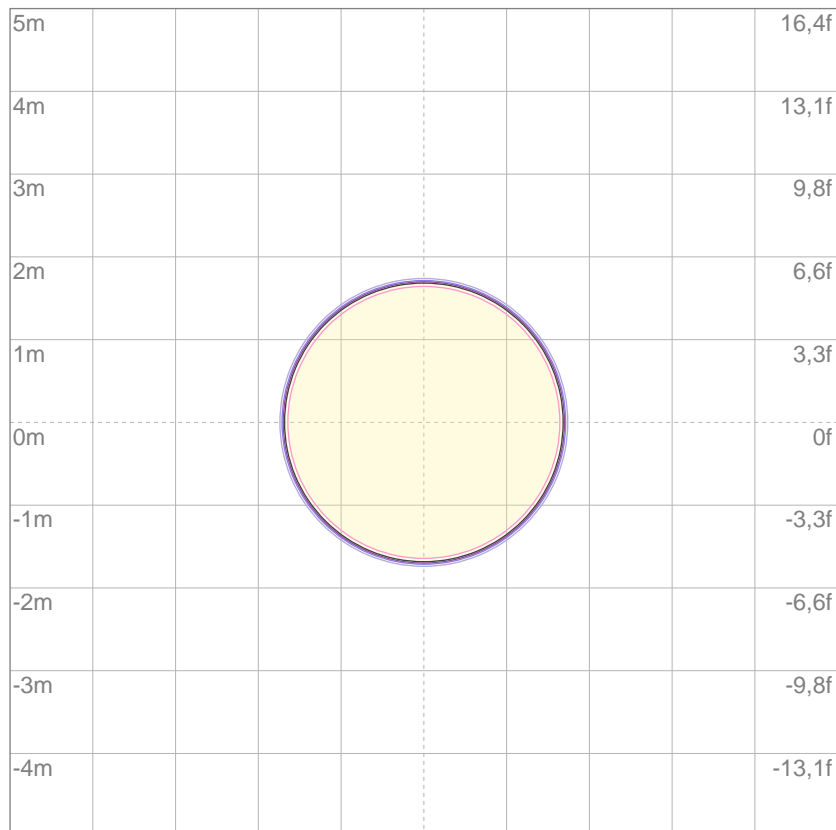

Mounting height: 10 meters (33 feet)

3%	0,896 lx
5%	1,49 lx
10%	2,99 lx
30%	8,96 lx
50%	14,9 lx

Conditions:

Number of c-planes: 2

Lux at center: 29,9 lx

Lux distribution on a surface when lamp is mounted at 10 meters from the surface.



Total lumen output:

244 lm

Peak candela output:

772 cd

Light quality:

CRI: 92,8

Color temperature:

2842 K

PRODUCT NAME:

ECLDISPLAYFC

MEASURAMENT CONDITIONS:

Beam angle:

Profile Max Zoom

Target:

2800K

Operator:

Paolo Carvone

Date and time:

14/01/2021 11:29:41

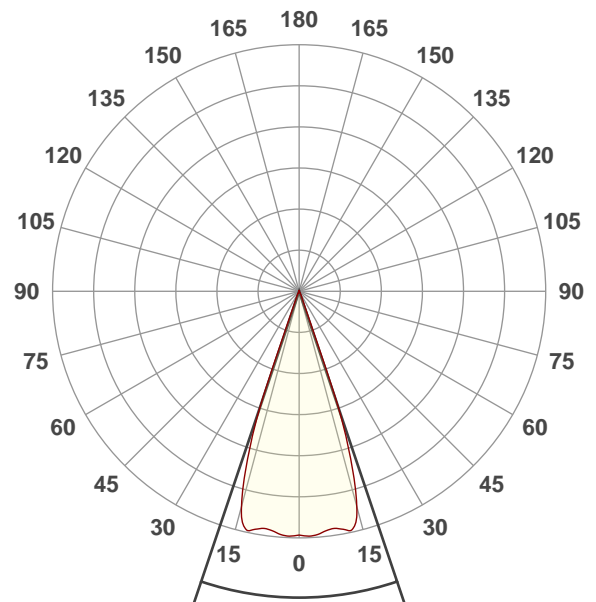

Beam angle 50%: 37,3°

Field angle 10%: 41°

Cut off angle 2.5%: 43,9°

Spectra

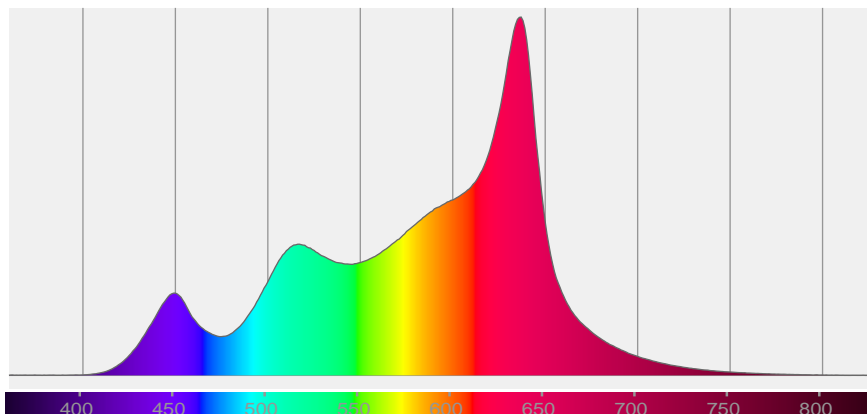

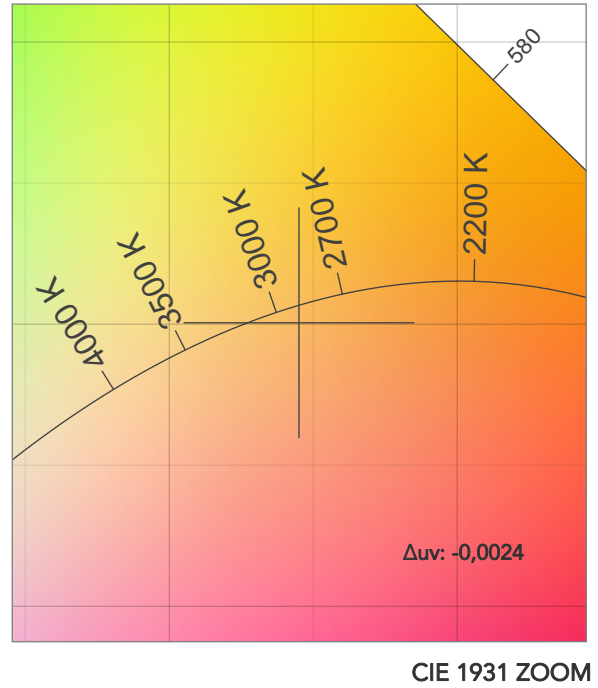
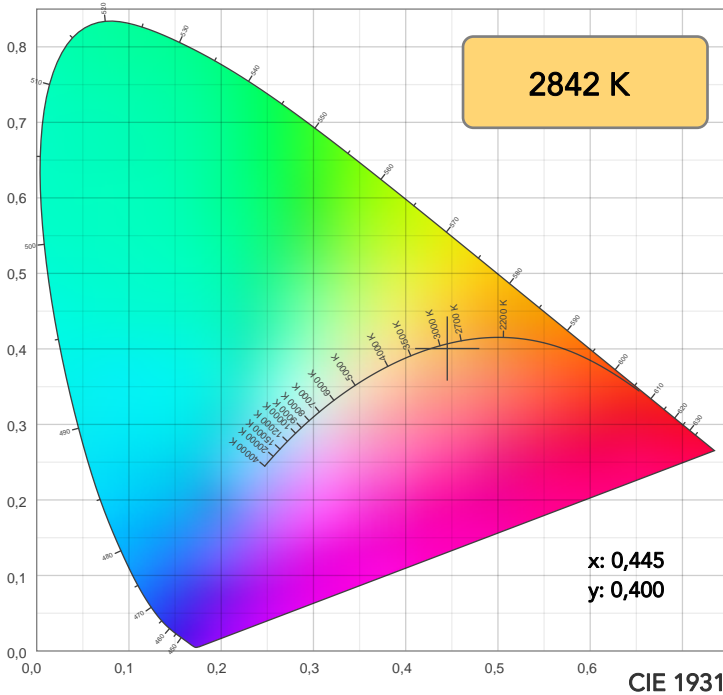

TM30: 91,3

CRI: 92,8 (R1-R8)

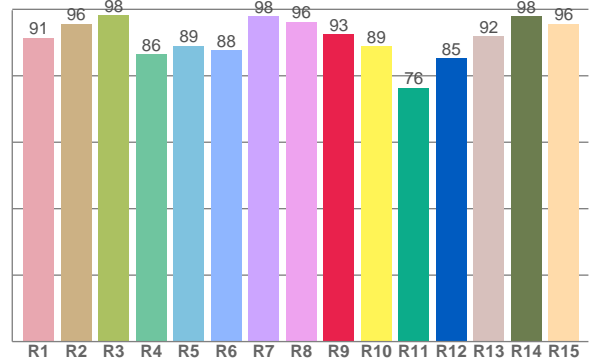
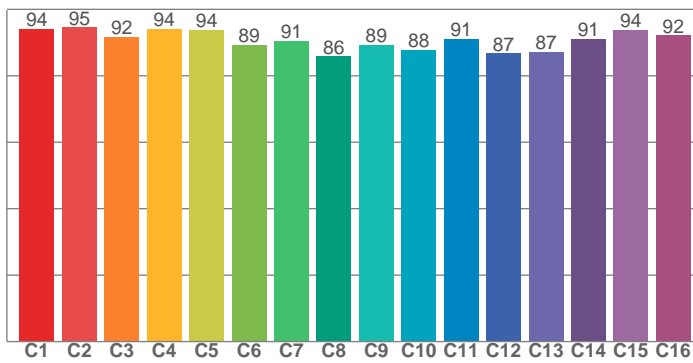

CRI R values, only R1-R8 are used to calculate final CRI value

R1	R2	R3	R4	R5	R6	R7	R8	R9	R10	R11	R12	R13	R14	R15
91,4	95,6	98,1	86,4	89,0	87,7	97,9	96,2	92,6	88,9	76,4	85,3	91,9	97,9	95,6

TM30 C values, 16 binned values out of total of 99 C values

C1	C2	C3	C4	C5	C6	C7	C8	C9	C10	C11	C12	C13	C14	C15	C16
94,0	94,5	91,7	94,1	93,9	89,4	90,5	85,9	89,3	87,8	91,1	86,7	87,2	91,1	93,8	92,1

CQS Q values

Q1	Q2	Q3	Q4	Q5	Q6	Q7	Q8	Q9	Q10	Q11	Q12	Q13	Q14	Q15
94,5	94,4	95,1	88,0	85,9	85,9	95,2	96,2	96,0	95,6	92,1	93,5	95,5	94,7	96,8

CQS: 92,1

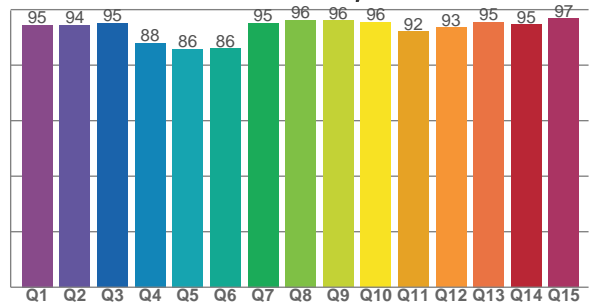

COLOR PARAMETERS

Color temperature	Color rendering index	Red component	Color fidelity	Color gamut	Color quality scale	Television lighting index	Color coordinate cie 1931	Color coordinate cie 1931	Color deviation from black body
CCT	CRI	CRI R9	TM30 Rf	TM30 Rg	CQS	TLCI	x	y	Δuv
2842 K	92,8	92,6	91,3	105,0	92,1	82	0,445	0,400	-0,0024

TM30 DETAILS

Rf 91,3
Fidelity index Rf

Rg 105,0
Gammut index

Hue Bin	R _f	Graphic shifts (%)	
		Chroma	Hue
1	94	1%	-1%
2	95	2%	-1%
3	92	2%	-1%
4	94	1%	-1%
5	94	2%	2%
6	89	5%	4%
7	91	5%	-1%
8	86	8%	-2%
9	89	4%	-4%
10	88	2%	-7%
11	91	1%	-6%
12	87	3%	-7%
13	87	2%	-9%
14	91	1%	-6%
15	94	1%	-2%
16	92	0%	-5%

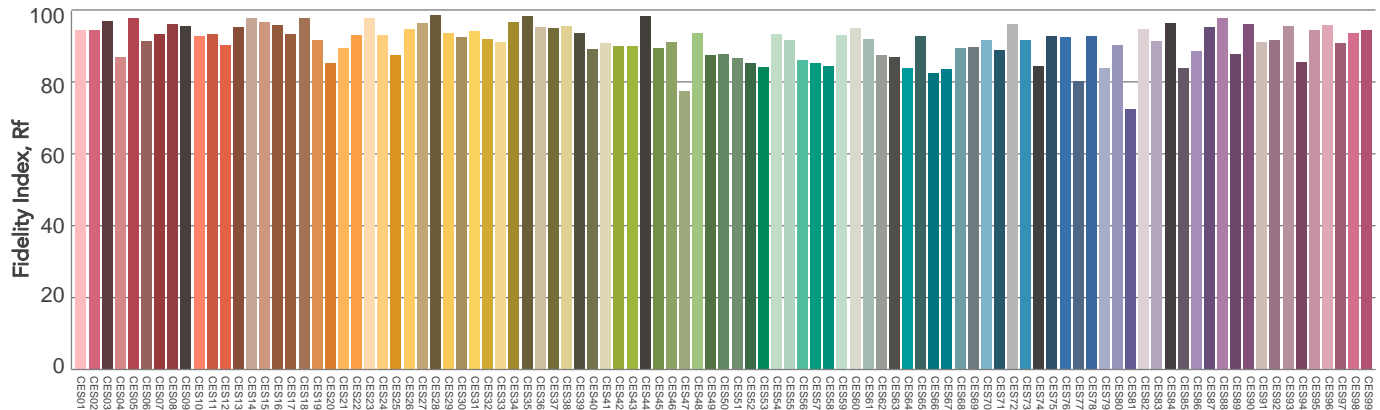
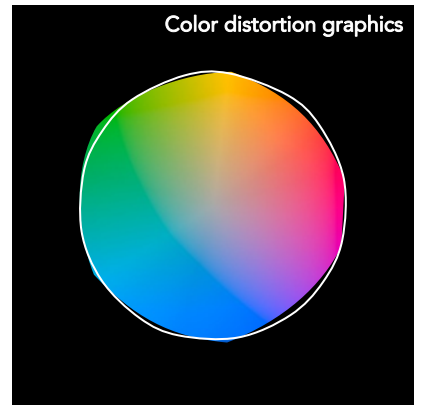
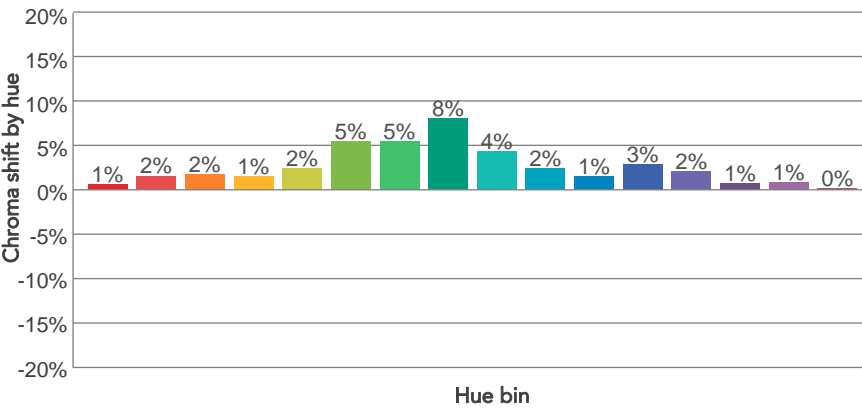
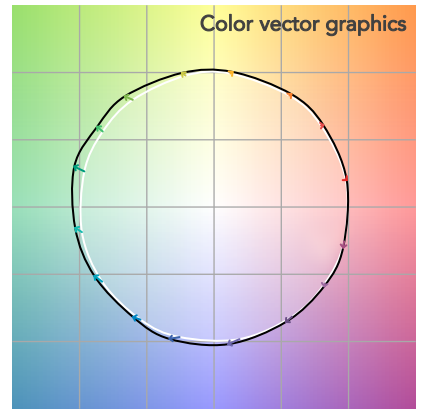
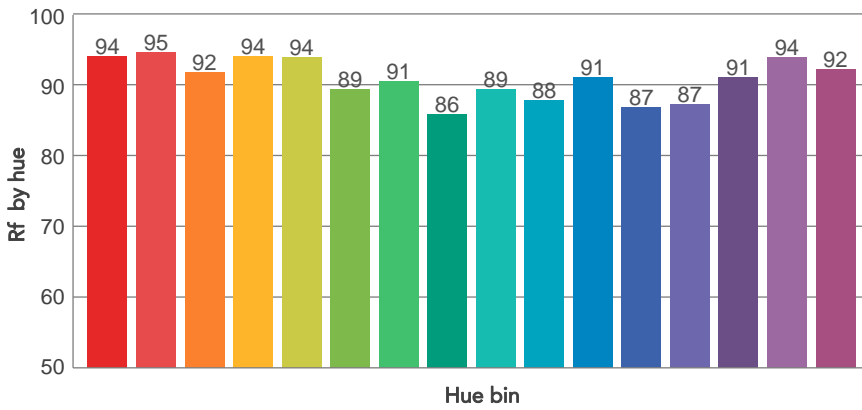
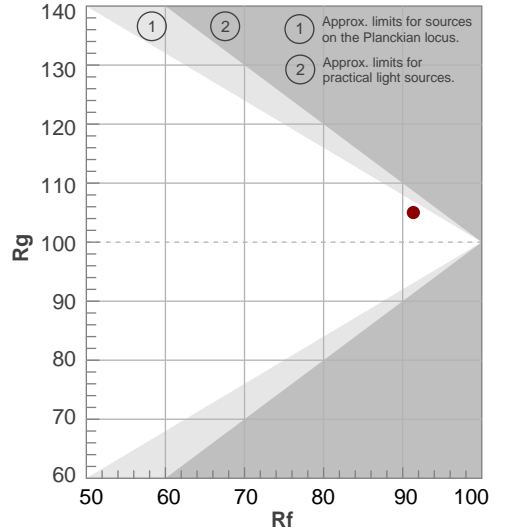

BEAM DETAILS



Beam angle 50%	Field angle 10%	Cut off angle 2,5%	Intensity ratio in 120° cone	Intensity ratio in 90° cone
37,3°	41°	43,9°	100,0%	100,0%

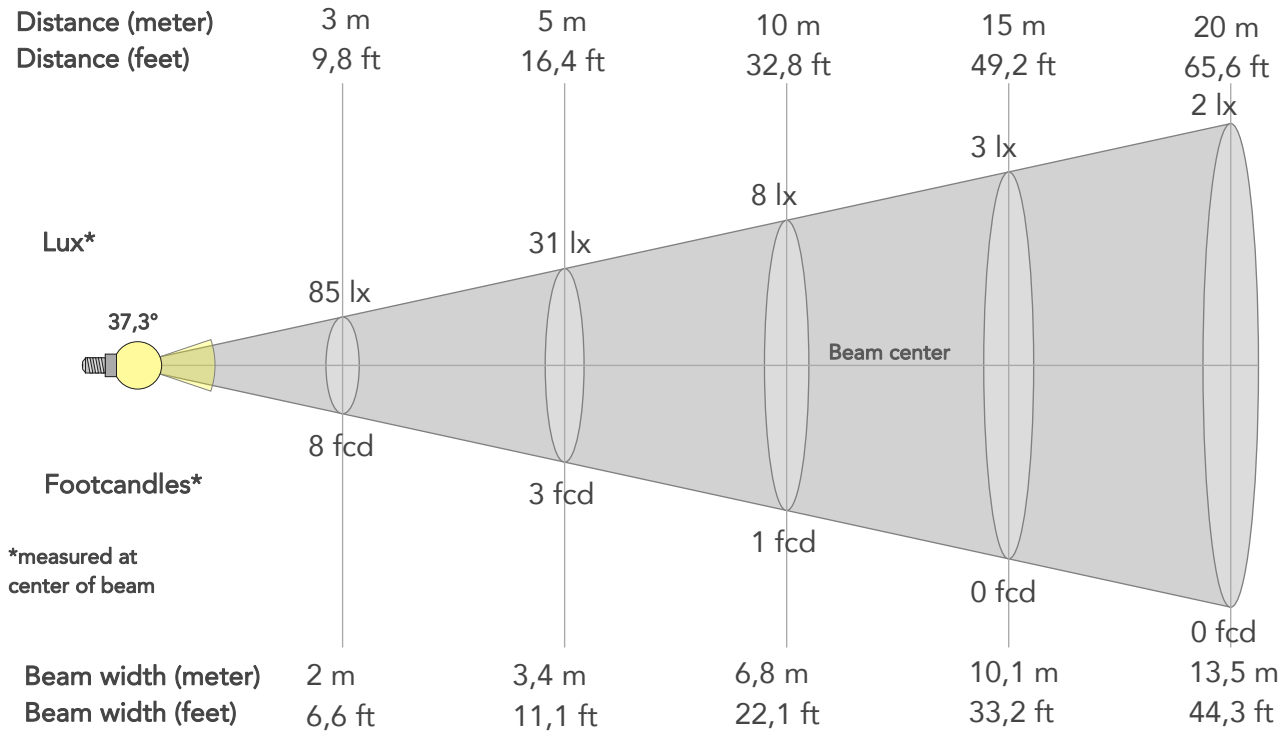

BEAM INTENSITIES AND WIDTHS

Distance	1m	2m	3m	4m	5m	7,5m	10m	15m	20m	25m	30m	40m	50m
Distance	3,3ft	6,6ft	9,8ft	13,1ft	16,4ft	24,6ft	32,8ft	49,2ft	65,6ft	82ft	98,4ft	131,2ft	164ft
Lux	768lx	192lx	85lx	48lx	31lx	14lx	8lx	3lx	2lx	1lx	1lx	0lx	0lx
Footcand.	71fcd	18fcd	8fcd	4fcd	3fcd	1fcd	1fcd	0fcd	0fcd	0fcd	0fcd	0fcd	0fcd
Beam wid.	0,7m	1,4m	2m	2,7m	3,4m	5,1m	6,8m	10,1m	13,5m	16,9m	20,3m	27m	33,8m
Beam wid.	2,2ft	4,5ft	6,6ft	8,8ft	11,1ft	16,6ft	22,1ft	33,2ft	44,3ft	55,4ft	66,4ft	88,6ft	110,7ft

LINEAR DISTRIBUTION DIAGRAM

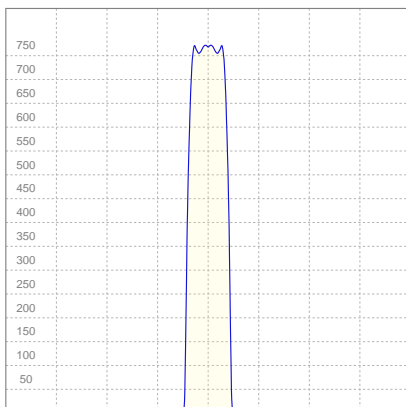

ELECTRICAL SPECIFICATIONS

Input voltage	Input current	Input power	Effeciency
224V	0,110A	22,4W	11lm/W

ISO CANDELA DIAGRAM

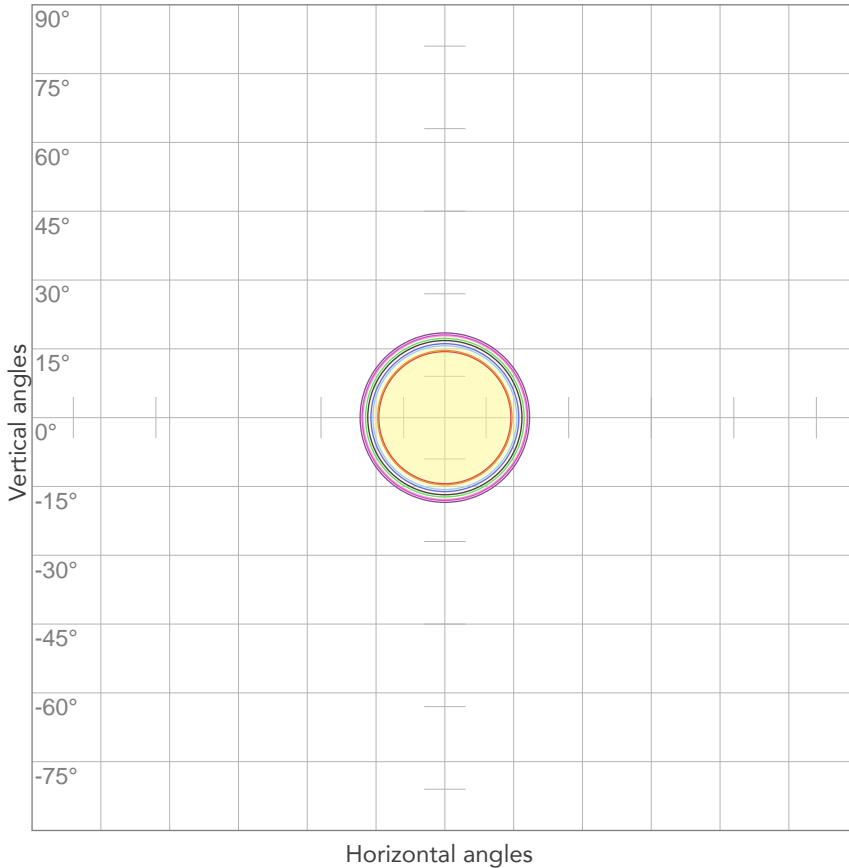

10%	77 cd
20%	154 cd
30%	230 cd
40%	307 cd
50%	384 cd
60%	461 cd
70%	538 cd
80%	615 cd

Conditions:

Number of c-planes: 2

Candela at center: 768 cd

ISO LUX DIAGRAM

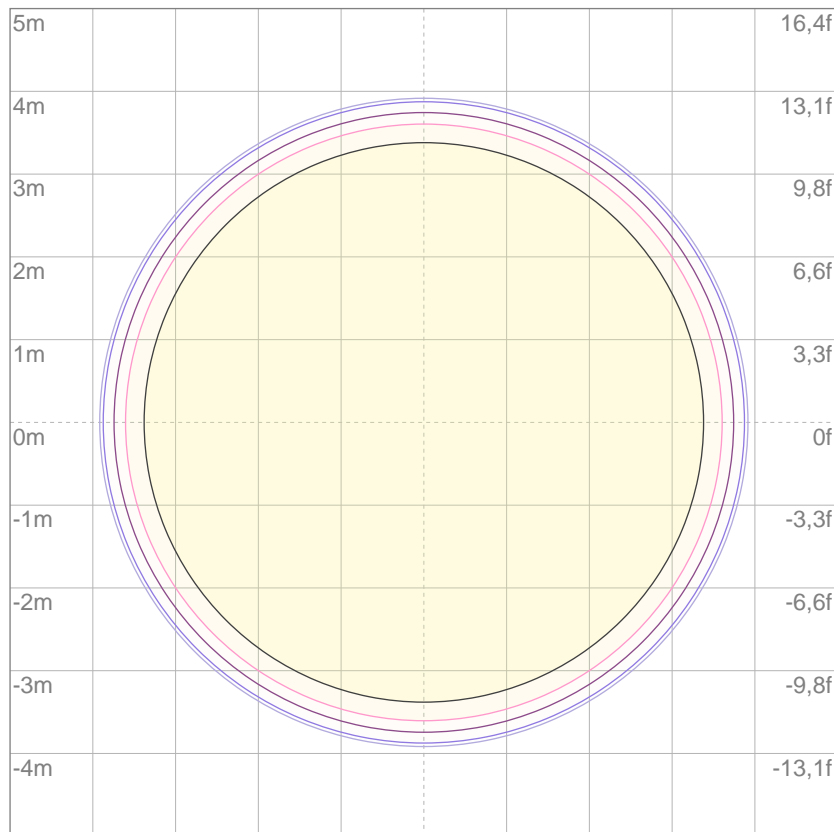

Mounting height: 10 meters (33 feet)

3%	0,230 lx
5%	0,384 lx
10%	0,768 lx
30%	2,30 lx
50%	3,84 lx

Conditions:

Number of c-planes: 2

Lux at center: 7,68 lx

Lux distribution on a surface when lamp is mounted at 10 meters from the surface.



Total lumen output:

274 lm

Peak candela output:

3733 cd

Light quality:

CRI: 93,1

Color temperature:

2842 K

PRODUCT NAME:

ECLDISPLAYFC

MEASURAMENT CONDITIONS:

Beam angle:

Profile Min Zoom

Target:

2800K

Operator:

Paolo Carvone

Date and time:

14/01/2021 11:15:02

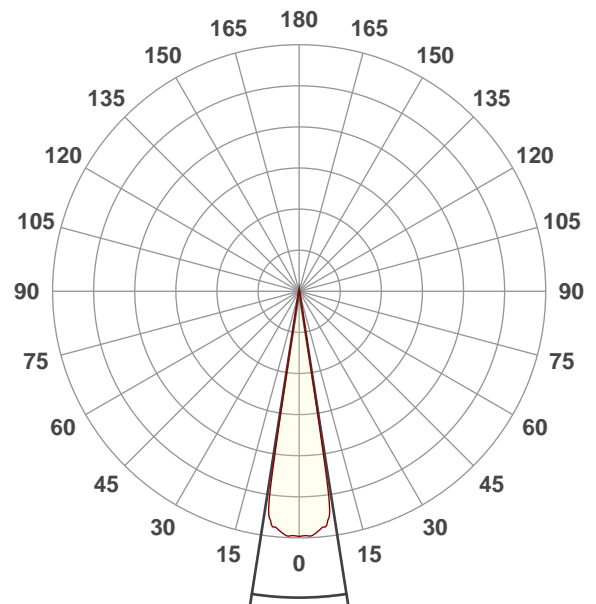

Spectra

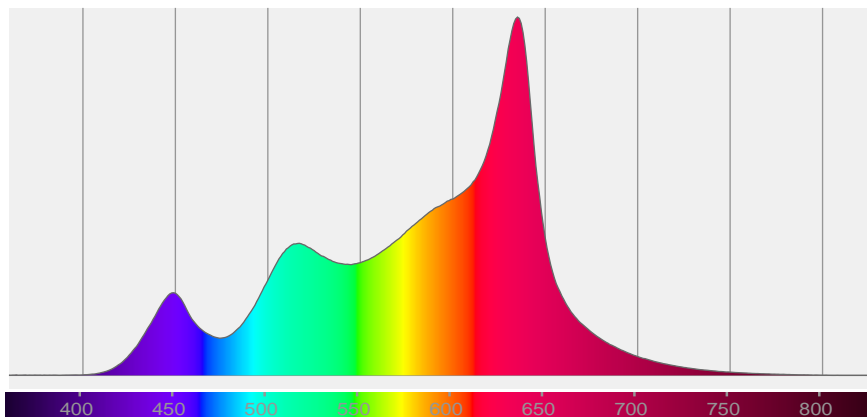

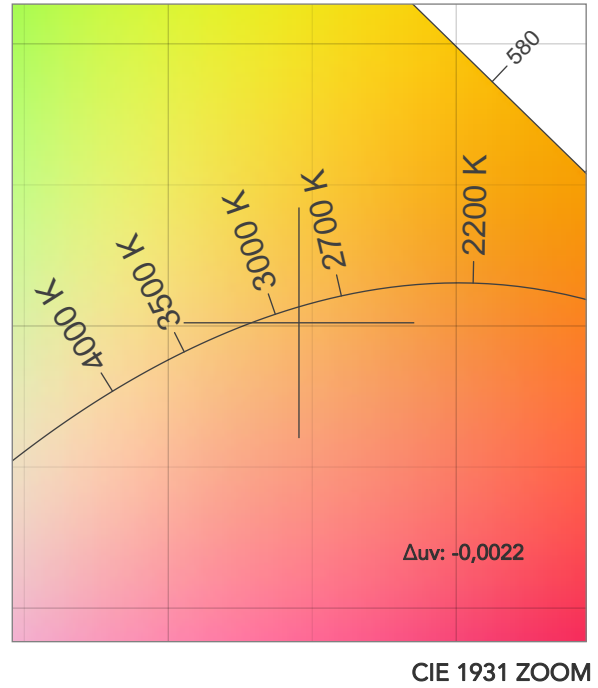
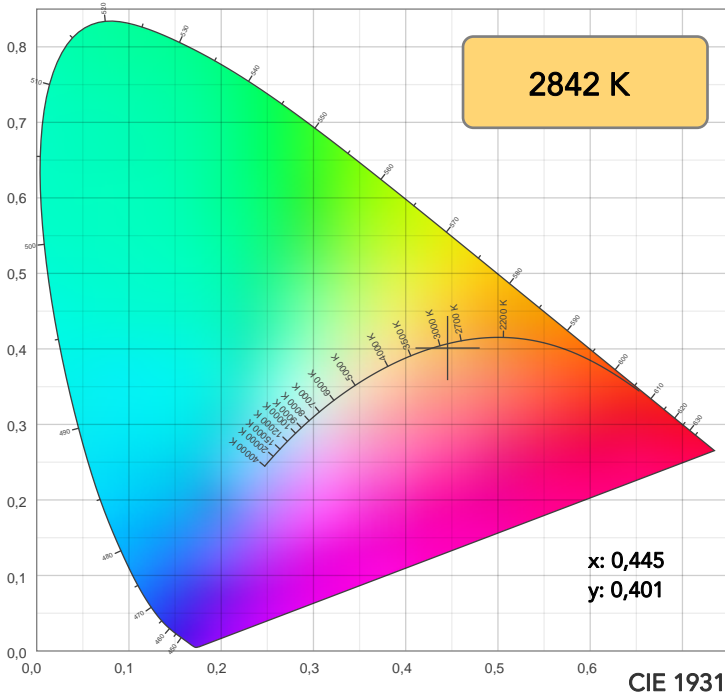

TM30: 91,1

CRI: 93,1 (R1-R8)

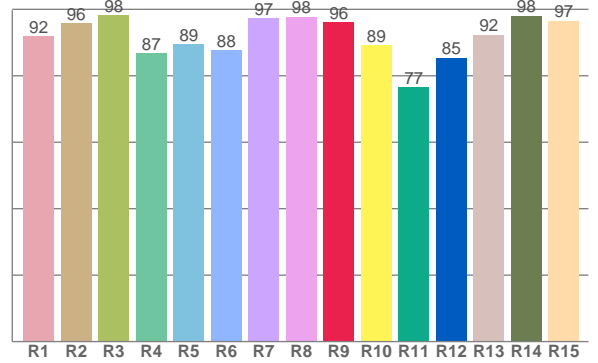
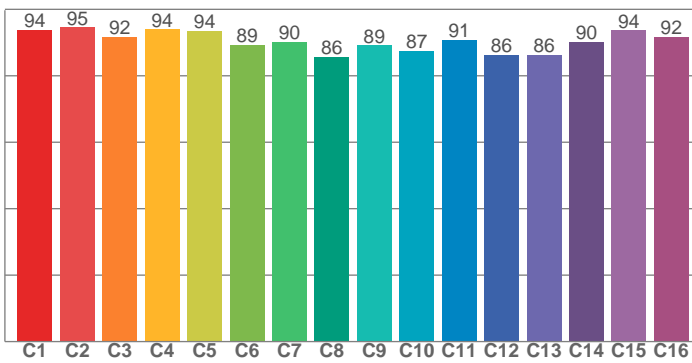

CRI R values, only R1-R8 are used to calculate final CRI value

R1	R2	R3	R4	R5	R6	R7	R8	R9	R10	R11	R12	R13	R14	R15
91,9	95,8	98,2	86,7	89,4	87,6	97,4	97,8	96,1	89,3	76,6	85,5	92,4	98,0	96,6

TM30 C values, 16 binned values out of total of 99 C values

C1	C2	C3	C4	C5	C6	C7	C8	C9	C10	C11	C12	C13	C14	C15	C16
93,9	94,6	91,7	93,9	93,5	89,3	90,3	85,6	89,1	87,4	90,8	86,3	86,3	90,2	93,6	91,7

CQS Q values

Q1	Q2	Q3	Q4	Q5	Q6	Q7	Q8	Q9	Q10	Q11	Q12	Q13	Q14	Q15
93,5	94,1	94,9	87,7	85,6	85,7	95,3	96,2	95,8	95,6	92,1	93,6	95,7	94,7	96,4

CQS: 92,0

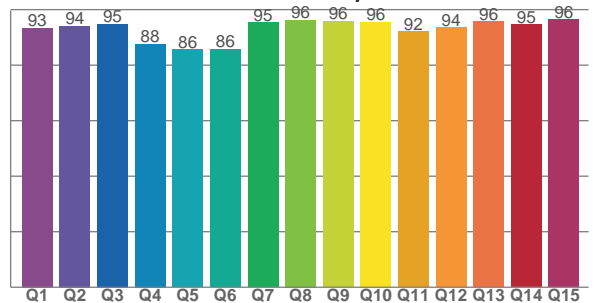

COLOR PARAMETERS

Color temperature	Color rendering index	Red component	Color fidelity	Color gamut	Color quality scale	Television lighting index	Color coordinate cie 1931	Color coordinate cie 1931	Color deviation from black body
CCT	CRI	CRI R9	TM30 Rf	TM30 Rg	CQS	TLCI	x	y	Δuv
2842 K	93,1	96,1	91,1	104,8	92,0	81	0,445	0,401	-0,0022

TM30 DETAILS

Rf 91,1
Fidelity index Rf

Rg 104,8
Gammut index

Hue Bin	R _f	Graphic shifts (%)	
		Chroma	Hue
1	94	0%	-1%
2	95	1%	-1%
3	92	2%	0%
4	94	2%	-1%
5	94	3%	2%
6	89	6%	4%
7	90	5%	-1%
8	86	8%	-2%
9	89	4%	-4%
10	87	2%	-7%
11	91	1%	-6%
12	86	3%	-7%
13	86	2%	-10%
14	90	1%	-7%
15	94	1%	-2%
16	92	0%	-5%

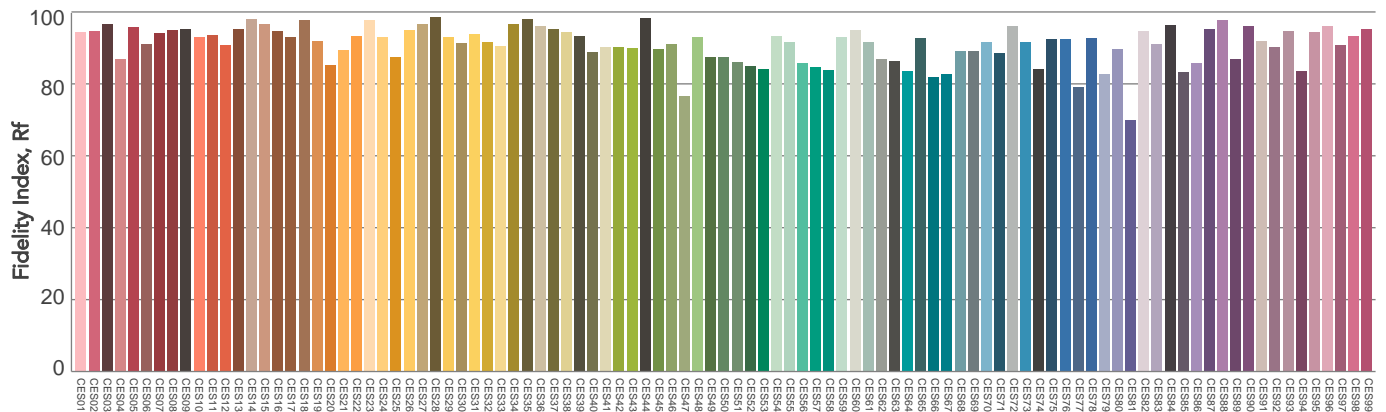
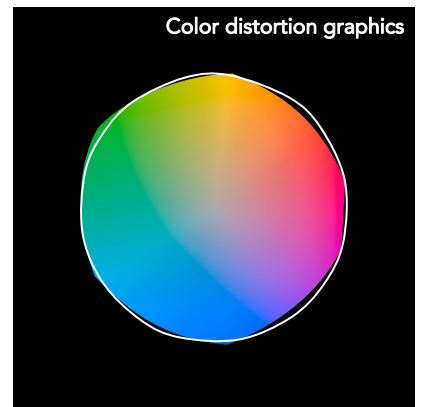
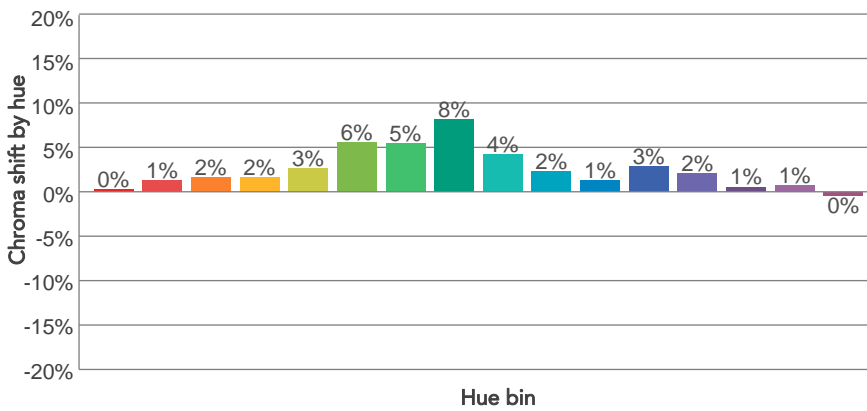
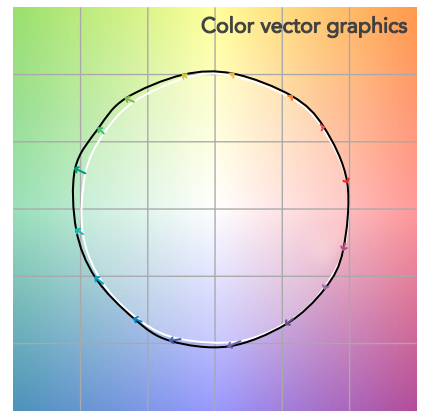
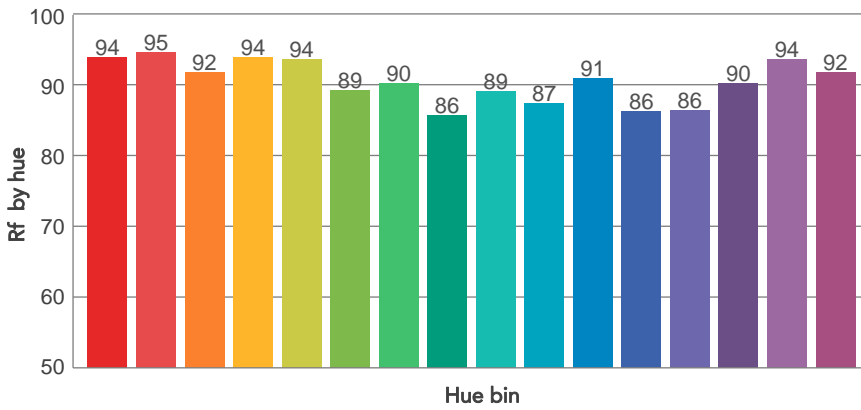
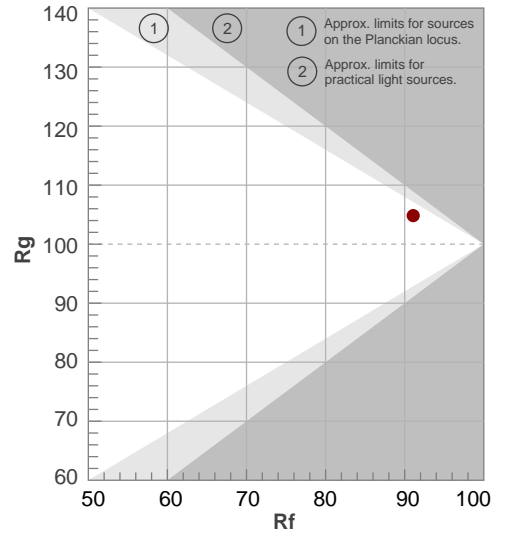

Color Evaluation Sample

BEAM DETAILS



Beam angle 50%	Field angle 10%	Cut off angle 2,5%	Intensity ratio in 120° cone	Intensity ratio in 90° cone
17,8°	19,3°	21,2°	100,0%	100,0%

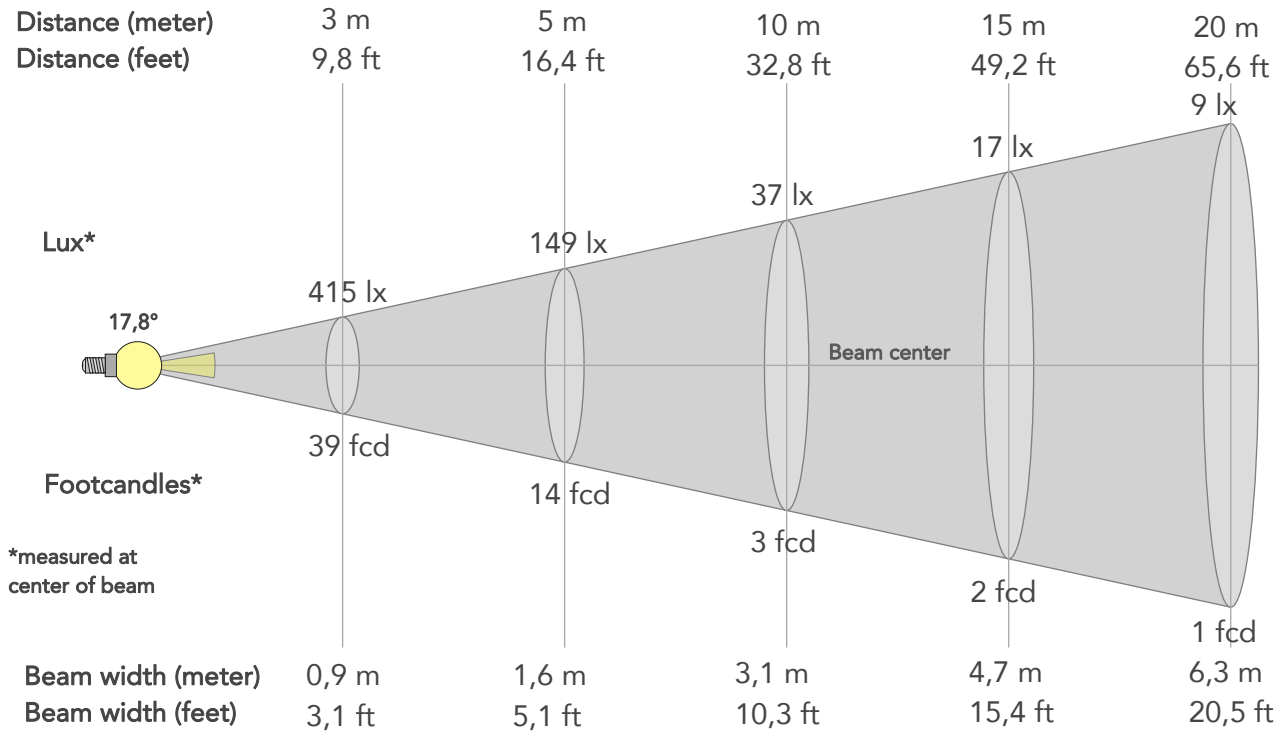

BEAM INTENSITIES AND WIDTHS

Distance	1m	2m	3m	4m	5m	7,5m	10m	15m	20m	25m	30m	40m	50m
Distance	3,3ft	6,6ft	9,8ft	13,1ft	16,4ft	24,6ft	32,8ft	49,2ft	65,6ft	82ft	98,4ft	131,2ft	164ft
Lux	3733lx	933lx	415lx	233lx	149lx	66lx	37lx	17lx	9lx	6lx	4lx	2lx	1lx
Footcand.	347fcd	87fcd	39fcd	22fcd	14fcd	6fcd	3fcd	2fcd	1fcd	1fcd	0fcd	0fcd	0fcd
Beam wid.	0,3m	0,6m	0,9m	1,3m	1,6m	2,3m	3,1m	4,7m	6,3m	7,8m	9,4m	12,5m	15,6m
Beam wid.	1ft	2,1ft	3,1ft	4,1ft	5,1ft	7,7ft	10,3ft	15,4ft	20,5ft	25,6ft	30,8ft	41ft	51,3ft

LINEAR DISTRIBUTION DIAGRAM

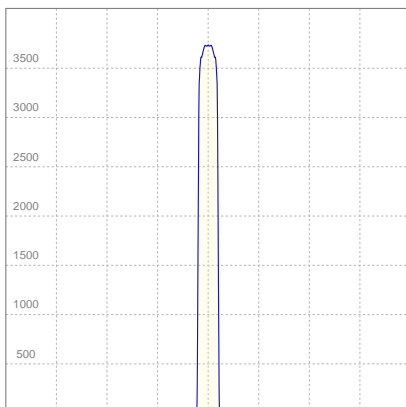

ELECTRICAL SPECIFICATIONS

Input voltage	Input current	Input power	Effeciency
224V	0,111A	22,5W	12lm/W

ISO CANDELA DIAGRAM

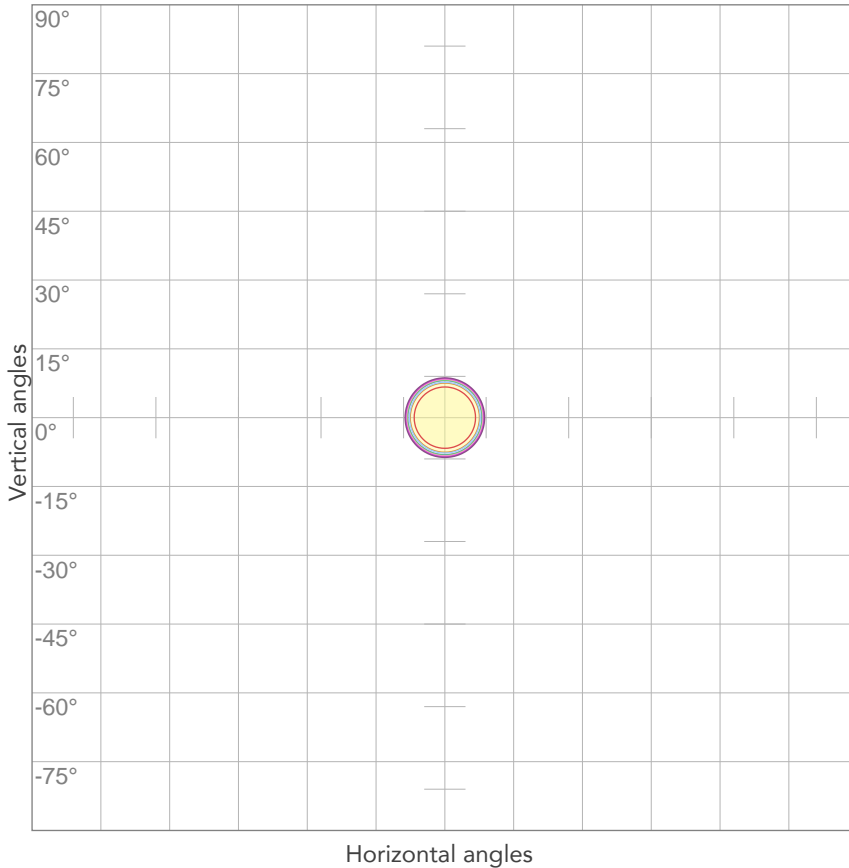

10%	373 cd
20%	747 cd
30%	1120 cd
40%	1493 cd
50%	1866 cd
60%	2240 cd
70%	2613 cd
80%	2986 cd

Conditions:

Number of c-planes: 2

Candela at center: 3733 cd

ISO LUX DIAGRAM

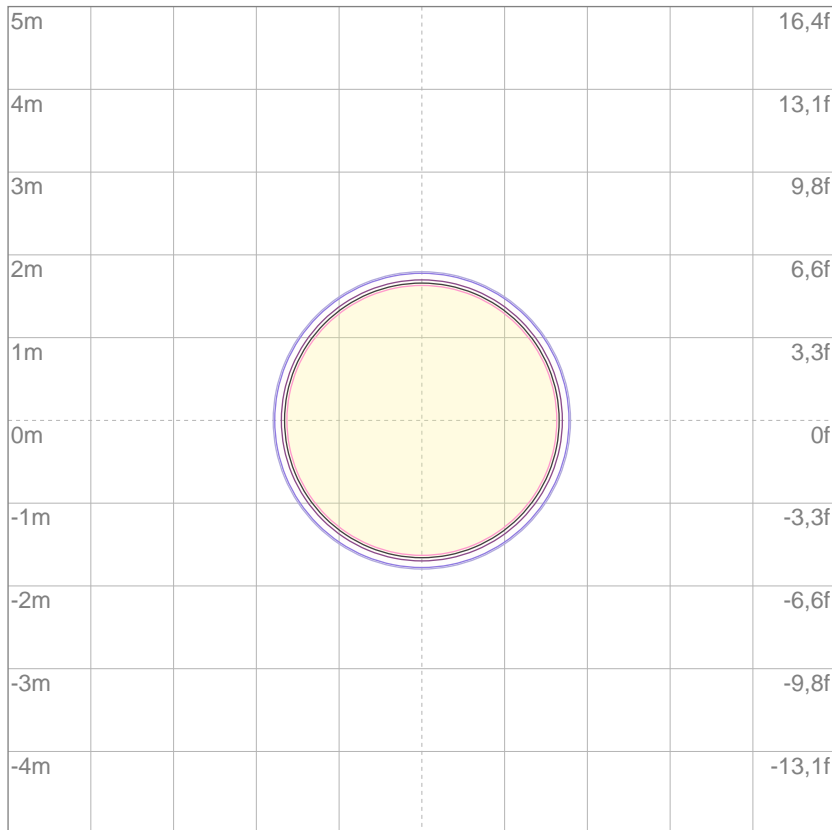

3%	1,12 lx
5%	1,87 lx
10%	3,73 lx
30%	11,2 lx
50%	18,7 lx

Conditions:

Number of c-planes: 2

Lux at center: 37,3 lx

Lux distribution on a surface when lamp is mounted at 10 meters from the surface.

Mounting height: 10 meters (33 feet)



Total lumen output:

248 lm

Peak candela output:

785 cd

Light quality:

CRI: 93,5

Color temperature:

3183 K

PRODUCT NAME:

ECLDISPLAYFC

MEASURAMENT CONDITIONS:

Beam angle:

Profile Max Zoom

Target:

3200K

Operator:

Paolo Carvone

Date and time:

14/01/2021 11:31:21

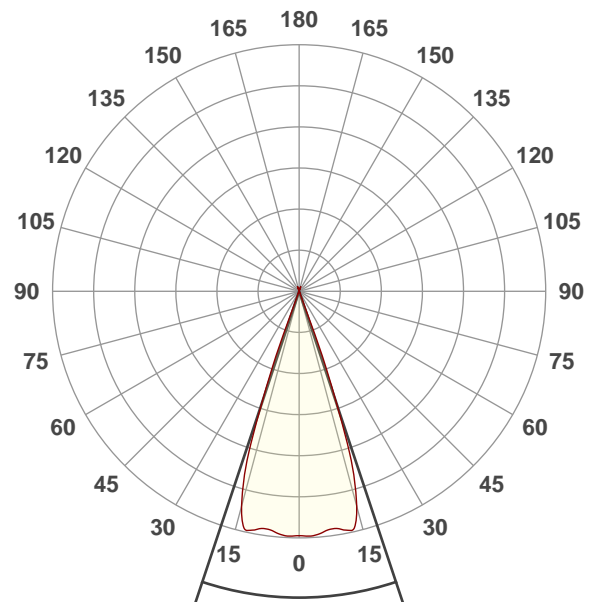

Beam angle 50%: 36,9°

Field angle 10%: 41,8°

Cut off angle 2.5%: 42,8°

Spectra

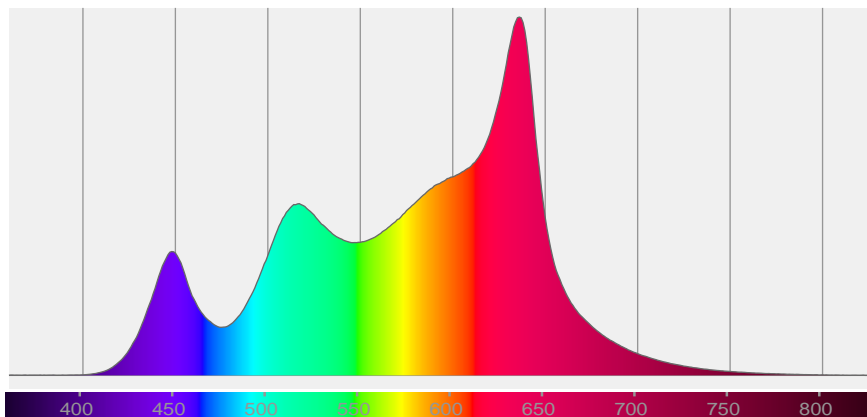

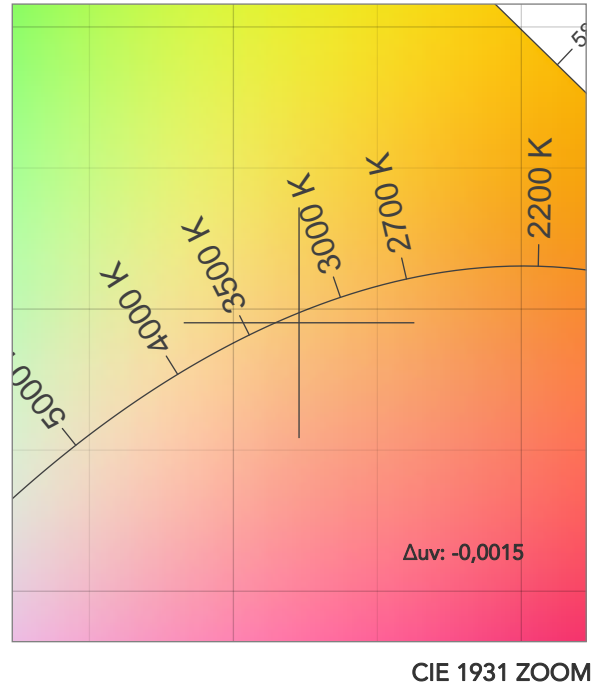
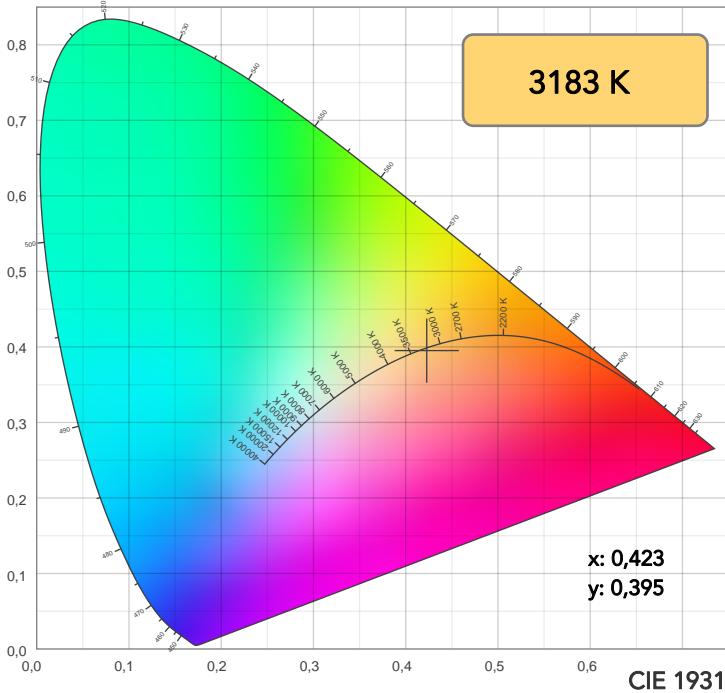

TM30: 92,0

CRI: 93,5 (R1-R8)

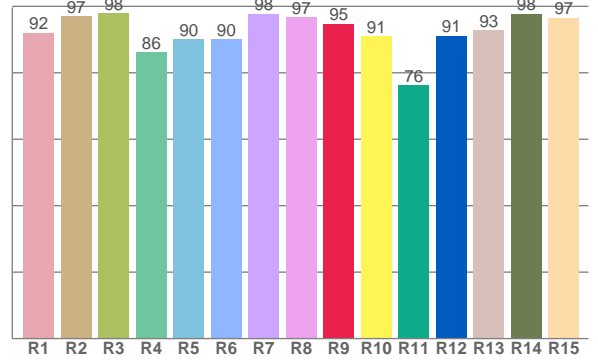
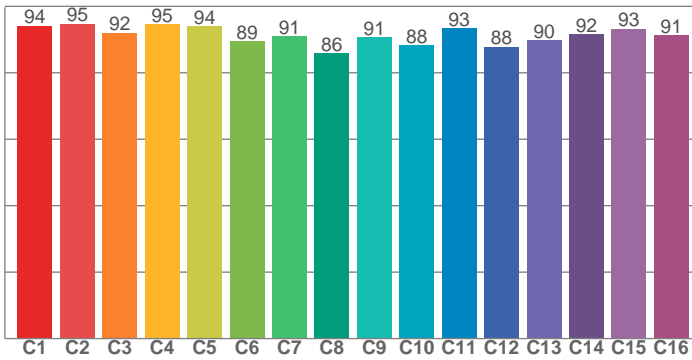

CRI R values, only R1-R8 are used to calculate final CRI value

R1	R2	R3	R4	R5	R6	R7	R8	R9	R10	R11	R12	R13	R14	R15
92,1	96,9	97,9	86,1	90,1	90,0	97,8	96,7	94,7	91,1	76,2	91,2	92,9	97,8	96,6

TM30 C values, 16 binned values out of total of 99 C values

C1	C2	C3	C4	C5	C6	C7	C8	C9	C10	C11	C12	C13	C14	C15	C16
94,2	94,7	92,1	94,6	93,9	89,4	91,0	85,8	90,7	88,3	93,4	87,8	89,7	91,6	93,2	91,3

CQS Q values

Q1	Q2	Q3	Q4	Q5	Q6	Q7	Q8	Q9	Q10	Q11	Q12	Q13	Q14	Q15
95,3	96,0	96,7	88,9	86,3	86,7	96,4	95,8	97,0	96,2	91,7	93,1	95,4	96,0	97,5

CQS: 92,7

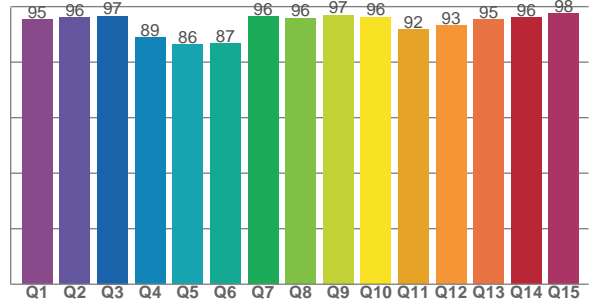

COLOR PARAMETERS

Color temperature	Color rendering index	Red component	Color fidelity	Color gamut	Color quality scale	Television lighting index	Color coordinate cie 1931	Color coordinate cie 1931	Color deviation from black body
CCT	CRI	CRI R9	TM30 Rf	TM30 Rg	CQS	TLCI	x	y	Δuv
3183 K	93,5	94,7	92,0	105,0	92,7	82	0,423	0,395	-0,0015

TM30 DETAILS

Rf 92,0
Fidelity index Rf

Rg 105,0
Gammut index

Hue Bin	R _f	Graphic shifts (%)	
		Chroma	Hue
1	94	1%	-1%
2	95	1%	-1%
3	92	1%	-1%
4	95	1%	-1%
5	94	2%	2%
6	89	5%	4%
7	91	5%	0%
8	86	8%	-2%
9	91	4%	-4%
10	88	2%	-6%
11	93	1%	-3%
12	88	4%	-7%
13	90	2%	-7%
14	92	1%	-5%
15	93	1%	-3%
16	91	2%	-6%

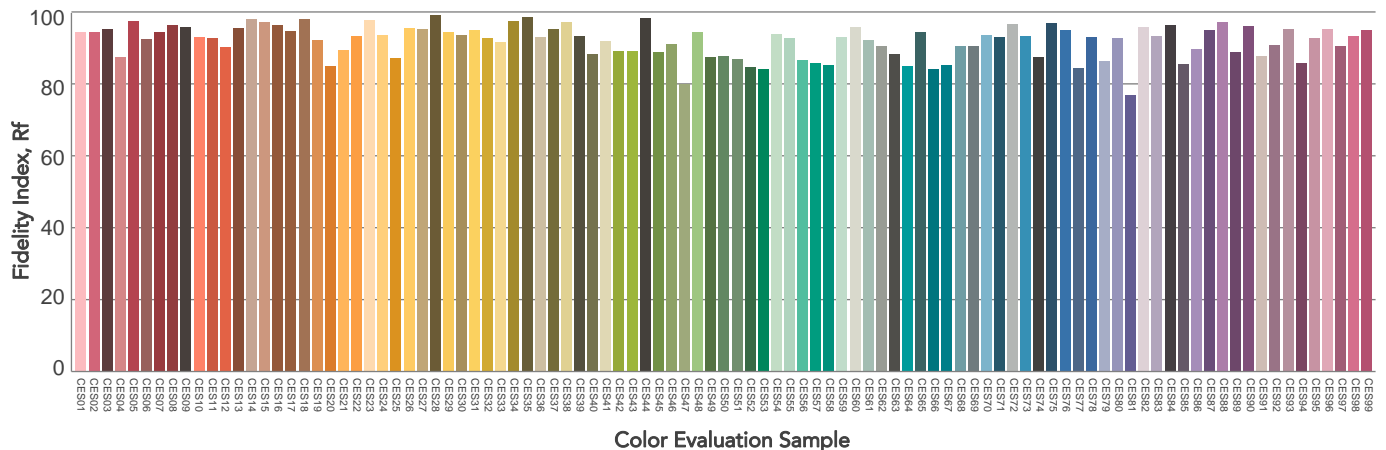
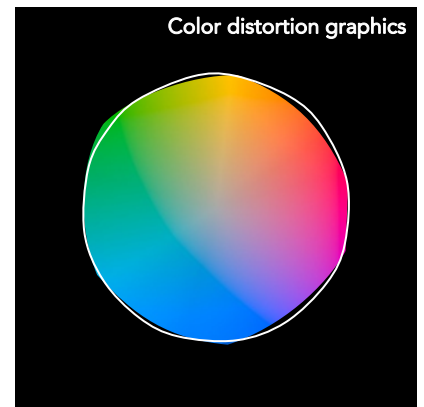
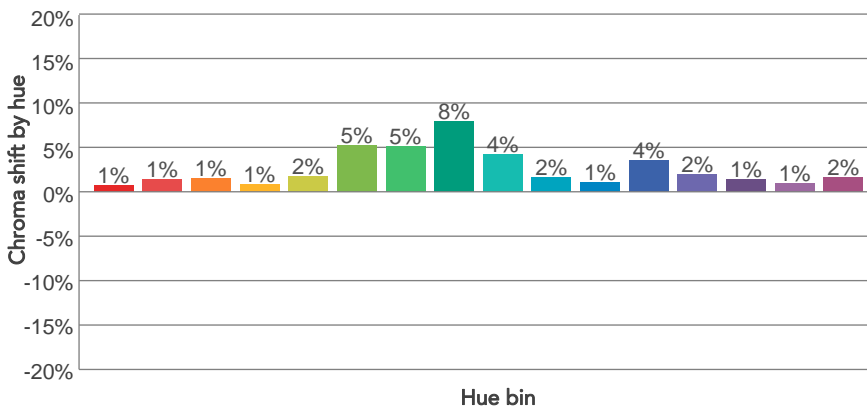
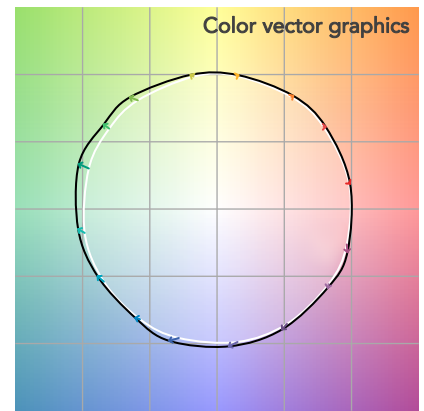
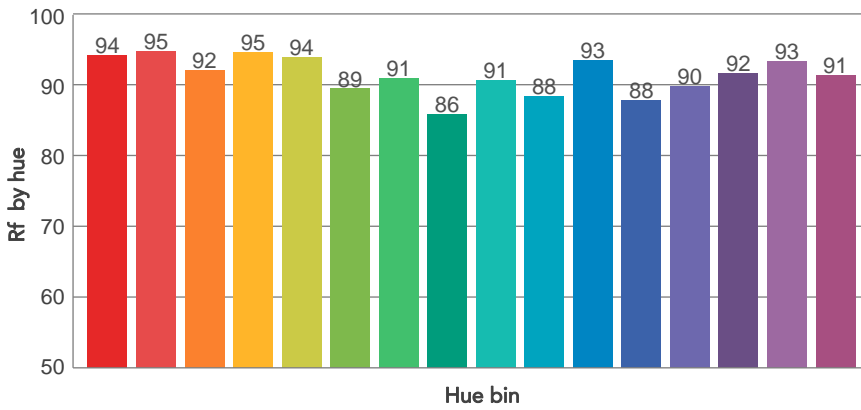
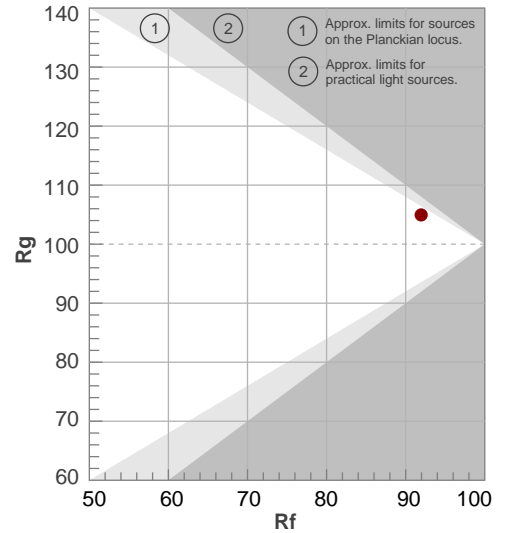

BEAM DETAILS



Beam angle 50%	Field angle 10%	Cut off angle 2,5%	Intensity ratio in 120° cone	Intensity ratio in 90° cone
36,9°	41,8°	42,8°	100,0%	100,0%

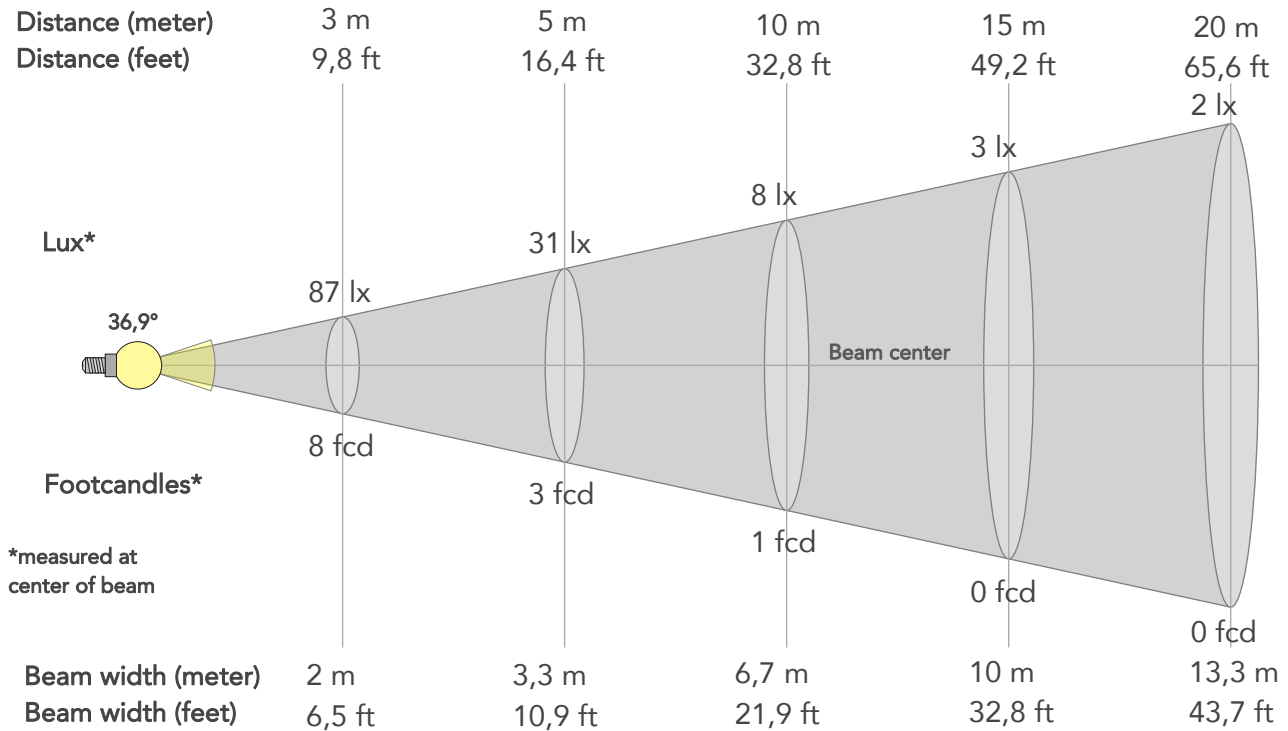

BEAM INTENSITIES AND WIDTHS

Distance	1m	2m	3m	4m	5m	7,5m	10m	15m	20m	25m	30m	40m	50m
Distance	3,3ft	6,6ft	9,8ft	13,1ft	16,4ft	24,6ft	32,8ft	49,2ft	65,6ft	82ft	98,4ft	131,2ft	164ft
Lux	783lx	196lx	87lx	49lx	31lx	14lx	8lx	3lx	2lx	1lx	1lx	0lx	0lx
Footcand.	73fcd	18fcd	8fcd	5fcd	3fcd	1fcd	1fcd	0fcd	0fcd	0fcd	0fcd	0fcd	0fcd
Beam wid.	0,7m	1,3m	2m	2,7m	3,3m	5m	6,7m	10m	13,3m	16,7m	20m	26,7m	33,3m
Beam wid.	2,2ft	4,4ft	6,5ft	8,7ft	10,9ft	16,4ft	21,9ft	32,8ft	43,7ft	54,6ft	65,6ft	87,4ft	109,3ft

LINEAR DISTRIBUTION DIAGRAM

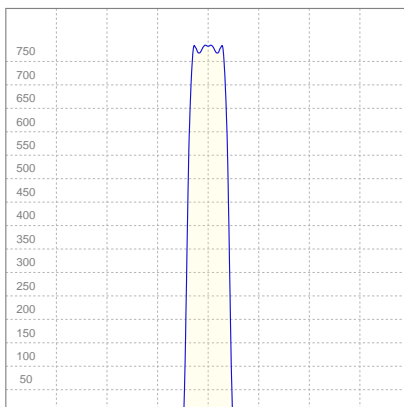

ELECTRICAL SPECIFICATIONS

Input voltage	Input current	Input power	Effeciency
223V	0,112A	22,8W	11lm/W

ISO CANDELA DIAGRAM

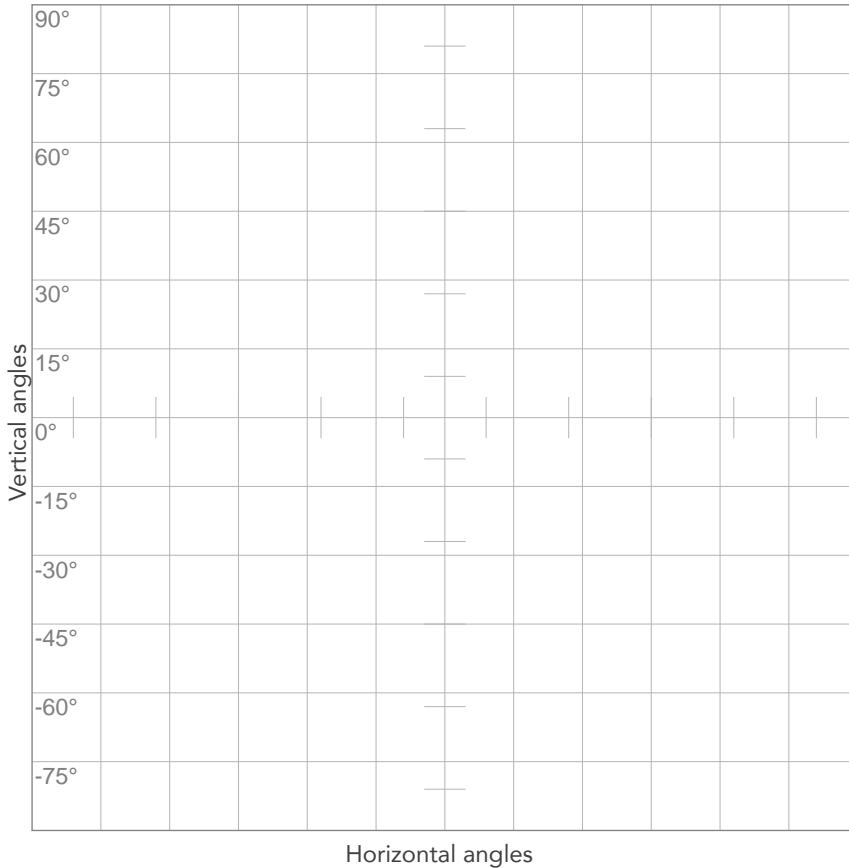

- 10% 78 cd
- 20% 157 cd
- 30% 235 cd
- 40% 313 cd
- 50% 391 cd
- 60% 470 cd
- 70% 548 cd
- 80% 626 cd

Conditions:

Number of c-planes: 2
Candela at center: 783 cd

ISO LUX DIAGRAM

45m	147,6f
36m	118,1f
27m	88,6f
18m	59,1f
9m	29,5f
0m	0f
-9m	-29,5f
-18m	-59,1f
-27m	-88,6f
-36m	-118,1f

Mounting height: 10 meters (33 feet)

- 3% 0,235 lx
- 5% 0,391 lx
- 10% 0,783 lx
- 30% 2,35 lx
- 50% 3,91 lx

Conditions:

Number of c-planes: 2
Lux at center: 7,83 lx

Lux distribution on a surface when lamp is mounted at 10 meters from the surface.



Total lumen output:

278 lm

Peak candela output:

3767 cd

Light quality:

CRI: 93,7

Color temperature:

3190 K

PRODUCT NAME:

ECLDISPLAYFC

MEASURAMENT CONDITIONS:

Beam angle:

Profile Min Zoom

Target:

3200K

Operator:

Paolo Carvone

Date and time:

14/01/2021 11:19:56

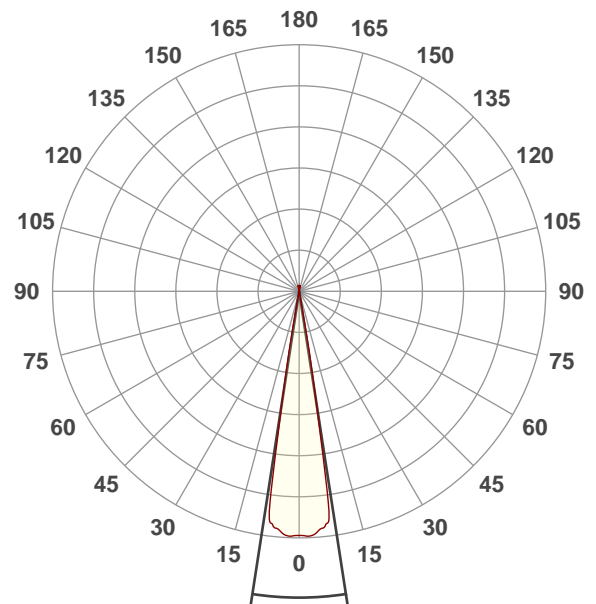

Beam angle 50%: 17,6°

Field angle 10%: 20,4°

Cut off angle 2.5%: 21,1°

Spectra

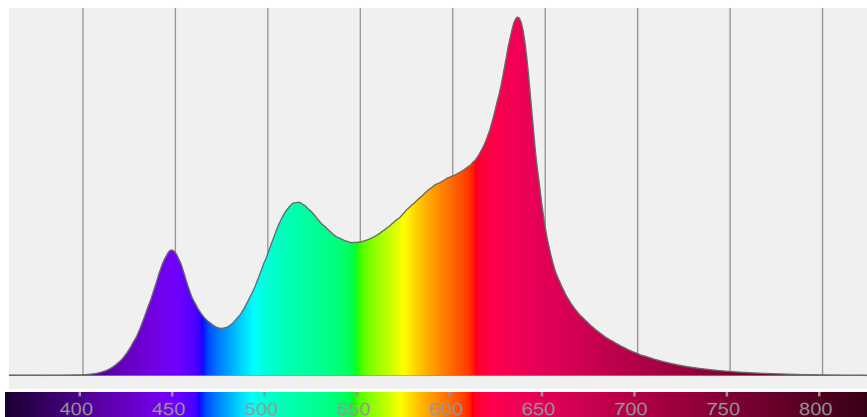

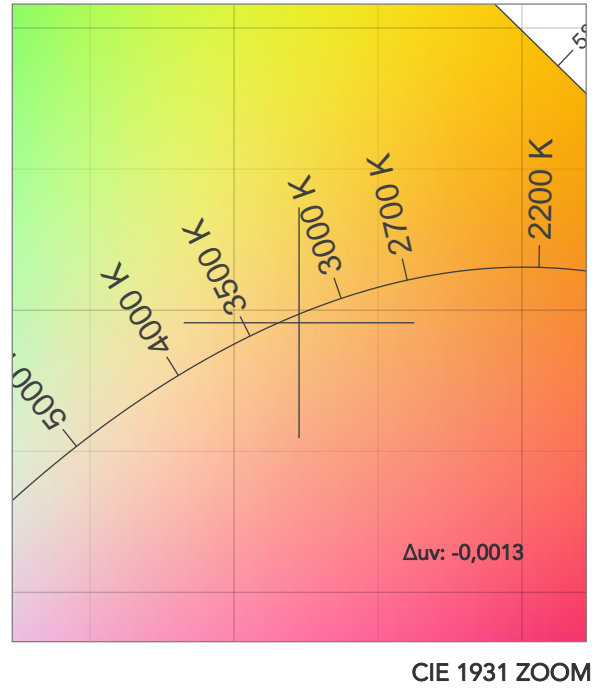
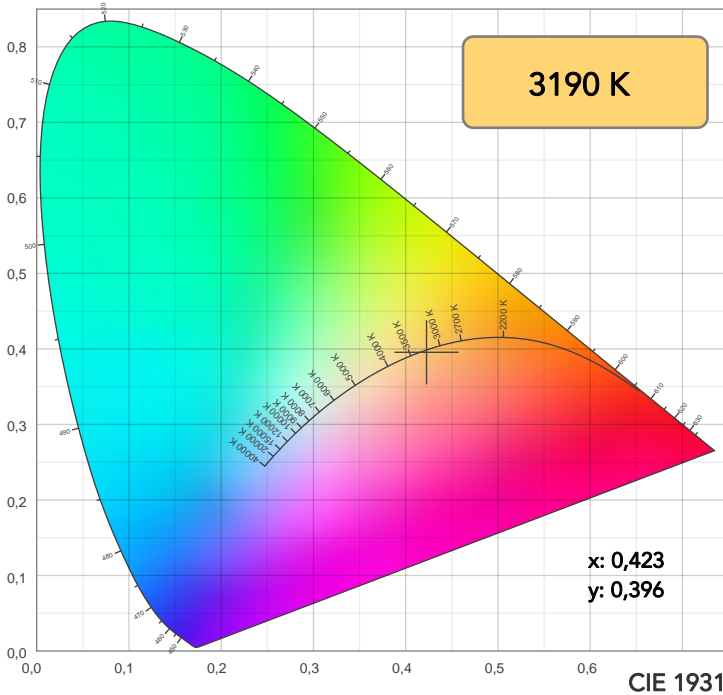

TM30: 91,8

CRI: 93,7 (R1-R8)

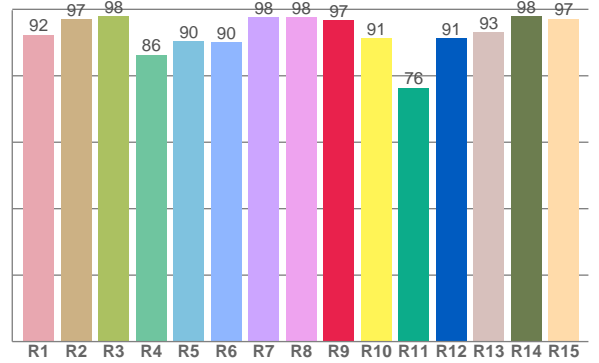
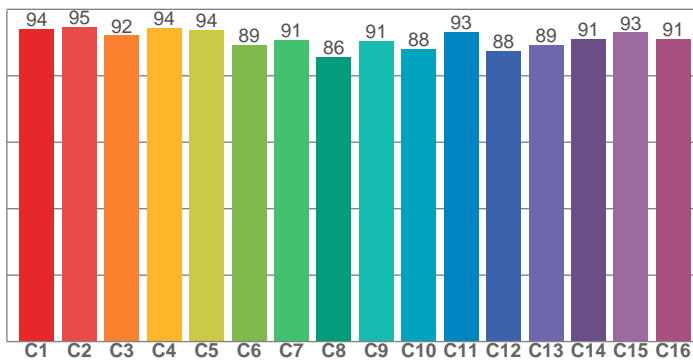

CRI R values, only R1-R8 are used to calculate final CRI value

R1	R2	R3	R4	R5	R6	R7	R8	R9	R10	R11	R12	R13	R14	R15
92,4	97,1	98,0	86,3	90,4	90,1	97,6	97,6	96,8	91,3	76,4	91,4	93,2	97,9	97,2

TM30 C values, 16 binned values out of total of 99 C values

C1	C2	C3	C4	C5	C6	C7	C8	C9	C10	C11	C12	C13	C14	C15	C16
94,1	94,8	92,1	94,5	93,8	89,4	90,9	85,7	90,6	88,0	93,3	87,5	89,3	91,1	93,0	91,1

CQS Q values

Q1	Q2	Q3	Q4	Q5	Q6	Q7	Q8	Q9	Q10	Q11	Q12	Q13	Q14	Q15
94,7	95,9	96,6	88,6	86,1	86,5	96,5	95,8	96,8	96,1	91,7	93,1	95,5	96,1	97,2

CQS: 92,6

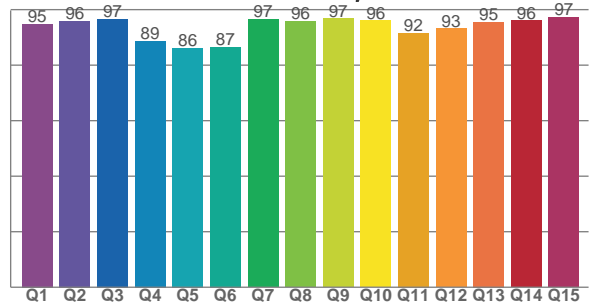

COLOR PARAMETERS

Color temperature	Color rendering index	Red component	Color fidelity	Color gamut	Color quality scale	Television lighting index	Color coordinate cie 1931	Color coordinate cie 1931	Color deviation from black body
CCT	CRI	CRI R9	TM30 Rf	TM30 Rg	CQS	TLCI	x	y	Δuv
3190 K	93,7	96,8	91,8	104,8	92,6	81	0,423	0,396	-0,0013

TM30 DETAILS

Rf 91,8
Fidelity index Rf

Rg 104,8
Gammut index

Hue Bin	R _f	Graphic shifts (%)	
		Chroma	Hue
1	94	0%	-1%
2	95	1%	-1%
3	92	1%	-1%
4	94	1%	-1%
5	94	2%	2%
6	89	5%	4%
7	91	5%	0%
8	86	8%	-2%
9	91	4%	-4%
10	88	2%	-6%
11	93	1%	-3%
12	88	3%	-7%
13	89	2%	-7%
14	91	1%	-6%
15	93	1%	-3%
16	91	1%	-6%

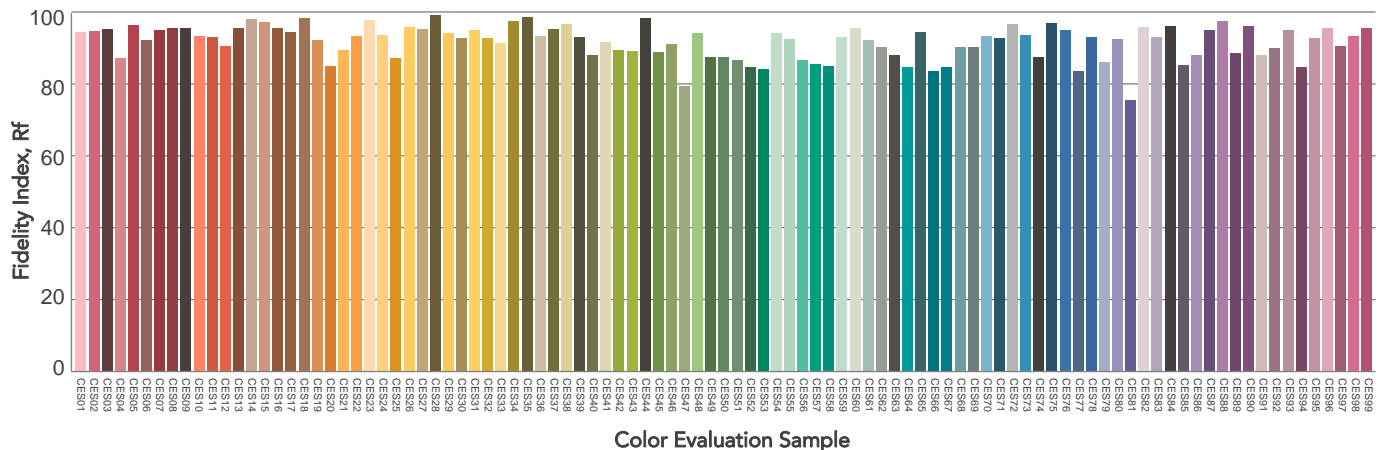
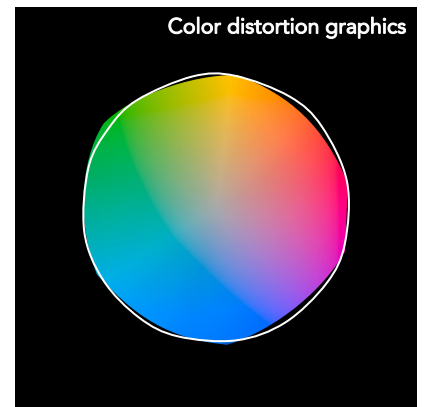
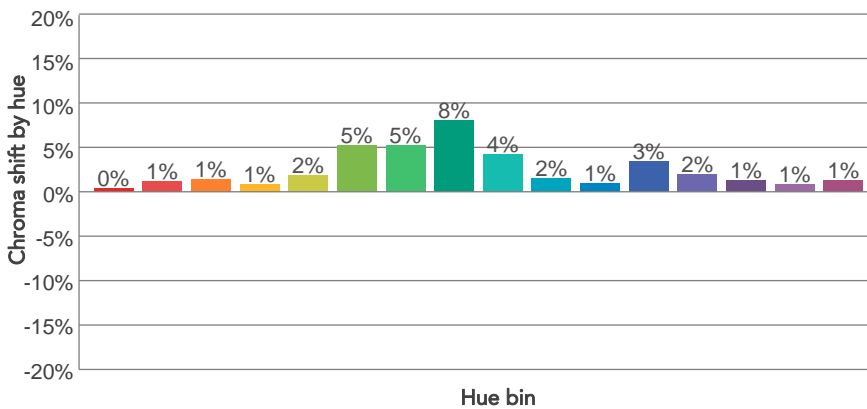
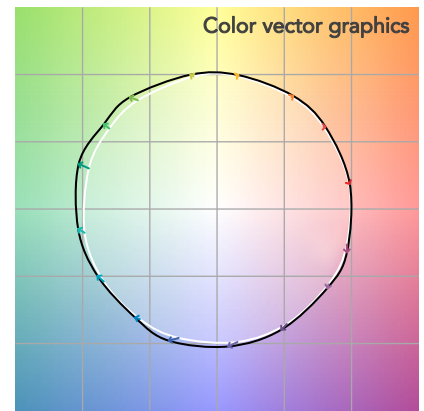
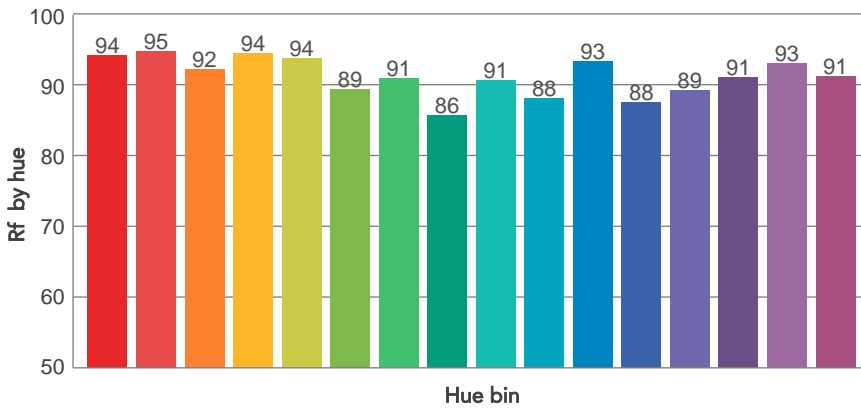
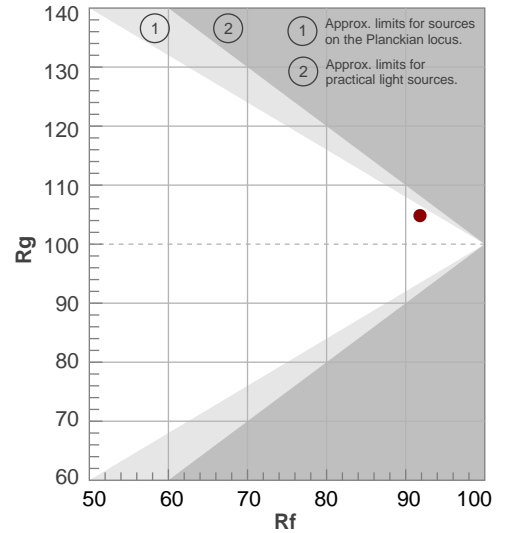

BEAM DETAILS



Beam angle 50%	Field angle 10%	Cut off angle 2,5%	Intensity ratio in 120° cone	Intensity ratio in 90° cone
17,6°	20,4°	21,1°	100,0%	100,0%

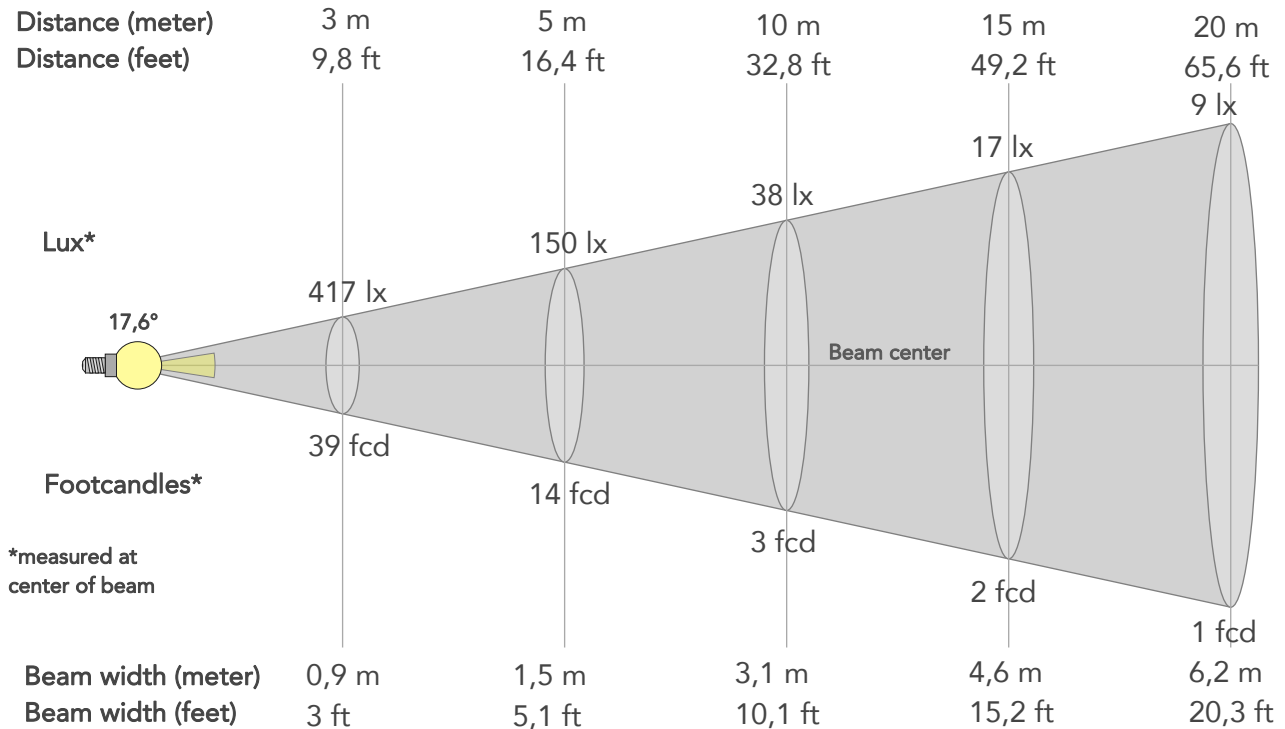

BEAM INTENSITIES AND WIDTHS

Distance	1m	2m	3m	4m	5m	7,5m	10m	15m	20m	25m	30m	40m	50m
Distance	3,3ft	6,6ft	9,8ft	13,1ft	16,4ft	24,6ft	32,8ft	49,2ft	65,6ft	82ft	98,4ft	131,2ft	164ft
Lux	3754lx	939lx	417lx	235lx	150lx	67lx	38lx	17lx	9lx	6lx	4lx	2lx	2lx
Footcand.	349fcd	87fcd	39fcd	22fcd	14fcd	6fcd	3fcd	2fcd	1fcd	1fcd	0fcd	0fcd	0fcd
Beam wid.	0,3m	0,6m	0,9m	1,2m	1,5m	2,3m	3,1m	4,6m	6,2m	7,7m	9,3m	12,4m	15,4m
Beam wid.	1ft	2ft	3ft	4ft	5,1ft	7,6ft	10,1ft	15,2ft	20,3ft	25,3ft	30,4ft	40,5ft	50,7ft

LINEAR DISTRIBUTION DIAGRAM

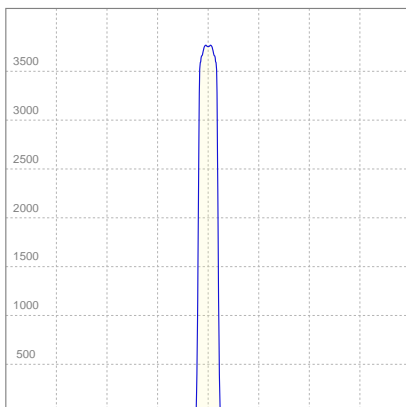

ELECTRICAL SPECIFICATIONS

Input voltage	Input current	Input power	Effeciency
223V	0,112A	22,9W	12lm/W

ISO CANDELA DIAGRAM

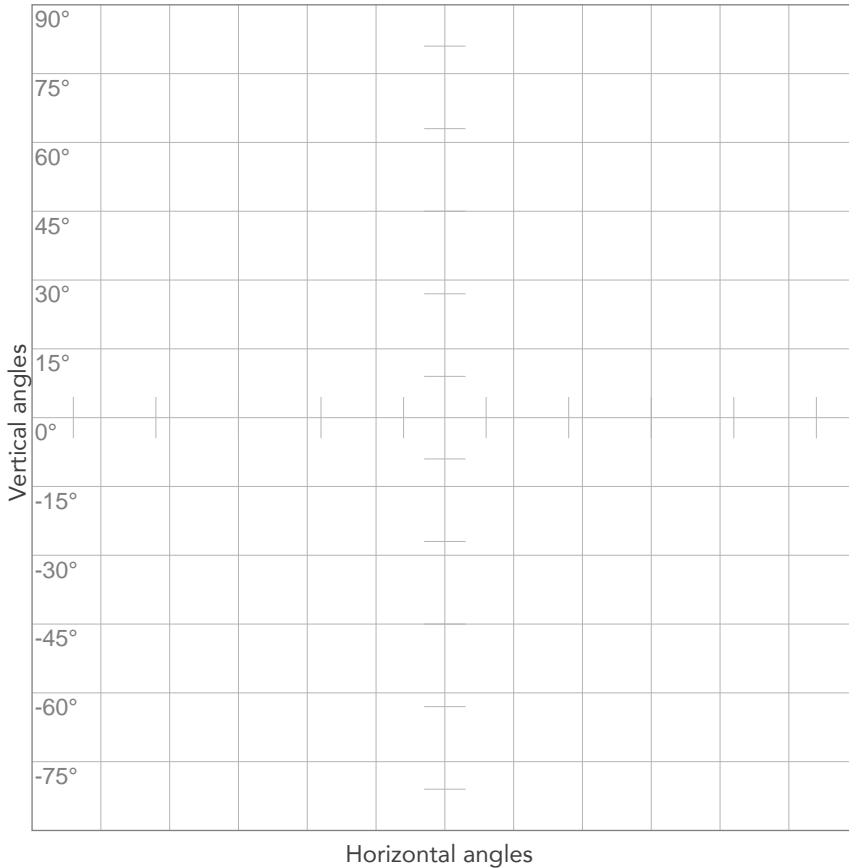

- 10% 375 cd
- 20% 751 cd
- 30% 1126 cd
- 40% 1502 cd
- 50% 1877 cd
- 60% 2253 cd
- 70% 2628 cd
- 80% 3004 cd

Conditions:

Number of c-planes: 2

Candela at center: 3754 cd

ISO LUX DIAGRAM

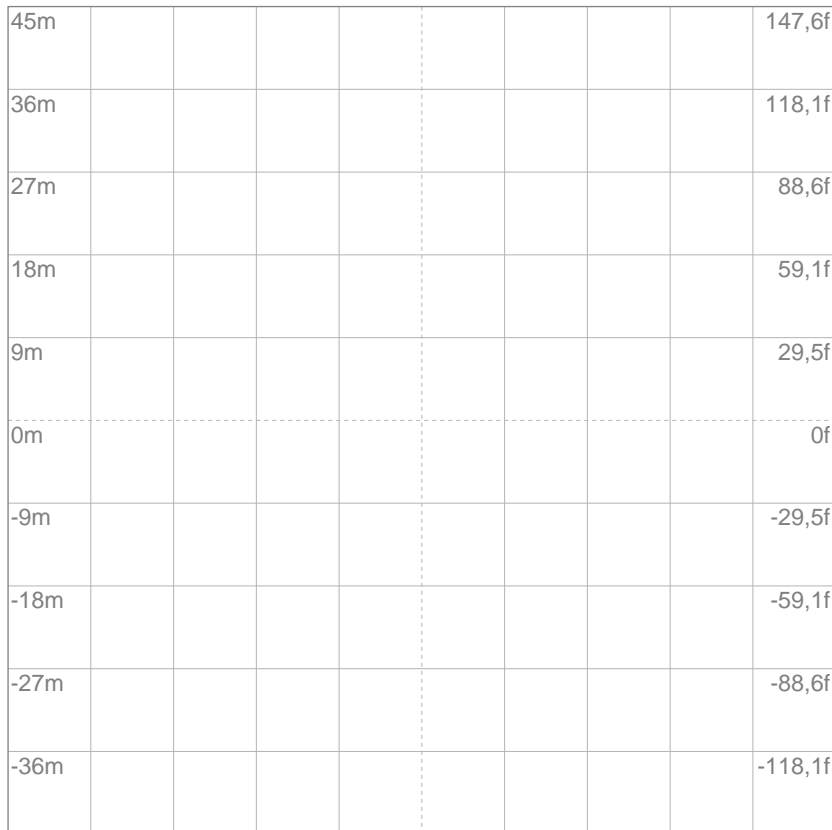

- 3% 1,13 lx
- 5% 1,88 lx
- 10% 3,75 lx
- 30% 11,3 lx
- 50% 18,8 lx

Conditions:

Number of c-planes: 2

Lux at center: 37,5 lx

Lux distribution on a surface when lamp is mounted at 10 meters from the surface.

Mounting height: 10 meters (33 feet)



Total lumen output:

258 lm

Peak candela output:

814 cd

Light quality:

CRI: 93,4

Color temperature:

3933 K

PRODUCT NAME:

ECLDISPLAYFC

MEASURAMENT CONDITIONS:

Beam angle:

Profile Max Zoom

Target:

4000K

Operator:

Paolo Carvone

Date and time:

14/01/2021 11:33:40

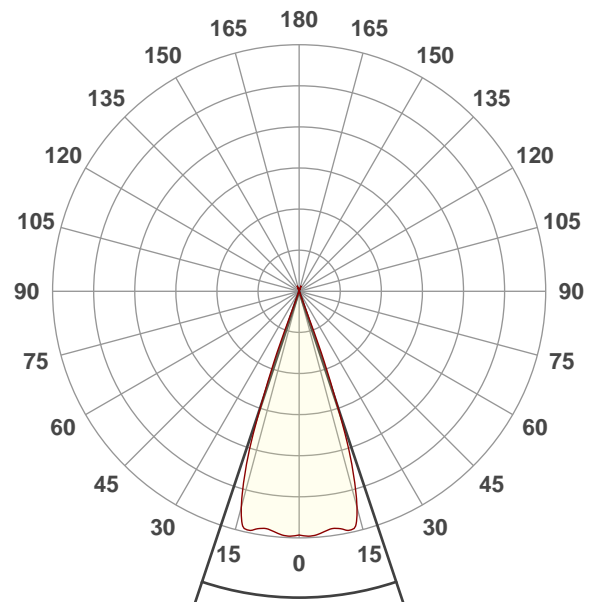

Beam angle 50%: 37°

Field angle 10%: 41,8°

Cut off angle 2.5%: 42,8°

Spectra

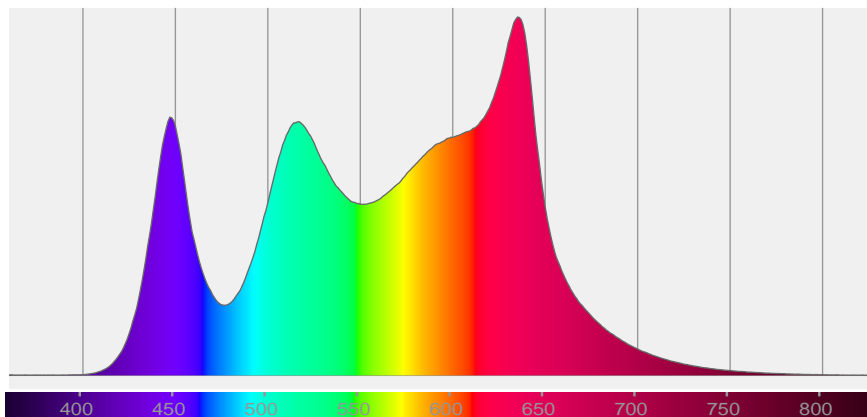

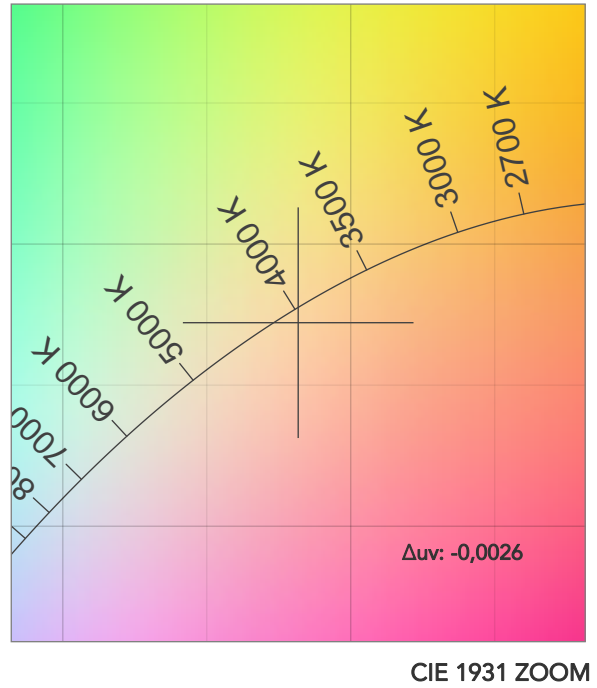
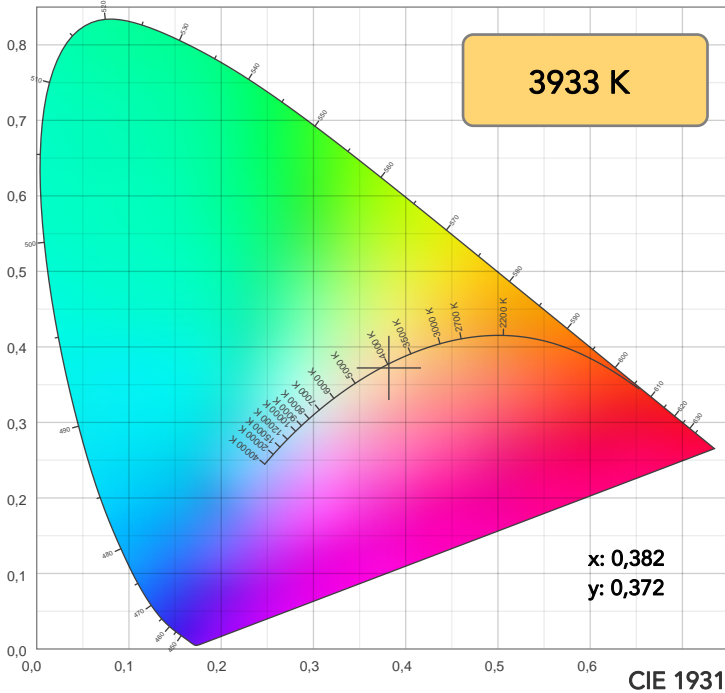

TM30: 92,1

CRI: 93,4 (R1-R8)

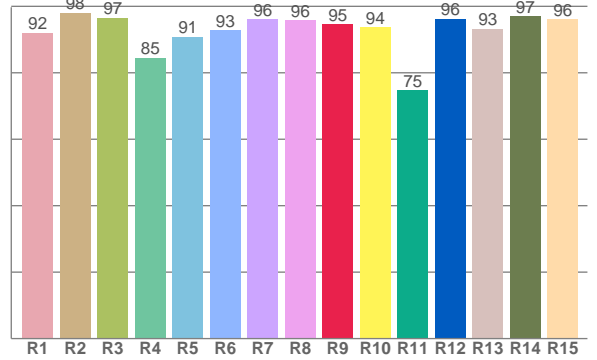
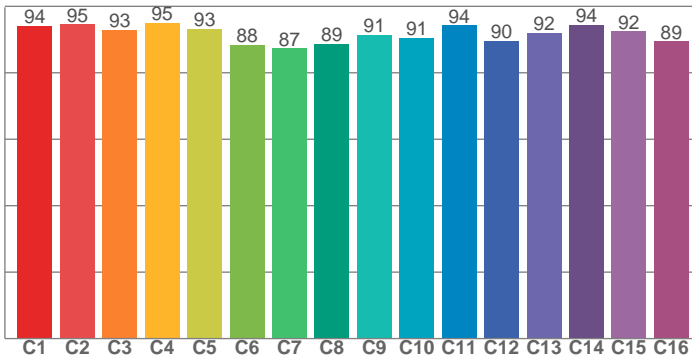

CRI R values, only R1-R8 are used to calculate final CRI value

R1	R2	R3	R4	R5	R6	R7	R8	R9	R10	R11	R12	R13	R14	R15
92,1	98,0	96,6	84,6	90,9	92,8	96,2	95,8	94,7	93,7	74,8	96,2	93,3	97,1	96,2

TM30 C values, 16 binned values out of total of 99 C values

C1	C2	C3	C4	C5	C6	C7	C8	C9	C10	C11	C12	C13	C14	C15	C16
94,1	94,6	93,0	95,0	93,2	88,4	87,3	88,7	91,3	90,6	94,3	89,6	91,9	94,5	92,4	89,4

CQS Q values

Q1	Q2	Q3	Q4	Q5	Q6	Q7	Q8	Q9	Q10	Q11	Q12	Q13	Q14	Q15
97,0	99,4	97,1	92,8	87,9	87,5	97,2	96,7	98,6	99,2	93,6	95,0	97,1	97,4	99,0

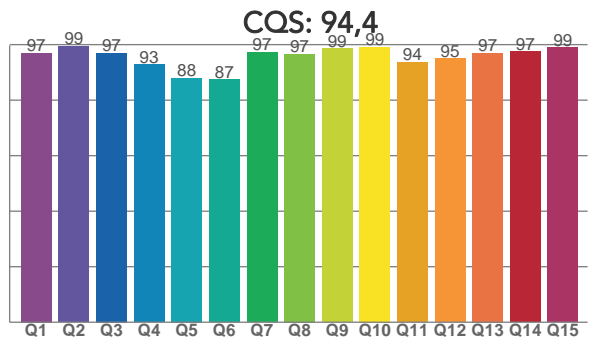

COLOR PARAMETERS

Color temperature	Color rendering index	Red component	Color fidelity	Color gamut	Color quality scale	Television lighting index	Color coordinate cie 1931	Color coordinate cie 1931	Color deviation from black body
CCT	CRI	CRI R9	TM30 Rf	TM30 Rg	CQS	TLCI	x	y	Δuv
3933 K	93,4	94,7	92,1	106,0	94,4	80	0,382	0,372	-0,0026

TM30 DETAILS

Rf 92,1
Fidelity index Rf

Rg 106,0
Gammut index

Hue Bin	R _f	Graphic shifts (%)	
		Chroma	Hue
1	94	1%	-2%
2	95	2%	-1%
3	93	1%	0%
4	95	1%	-1%
5	93	2%	2%
6	88	6%	4%
7	87	8%	1%
8	89	6%	-1%
9	91	4%	-4%
10	91	0%	-5%
11	94	2%	0%
12	90	3%	0%
13	92	4%	-4%
14	94	3%	0%
15	92	3%	-2%
16	89	3%	-5%

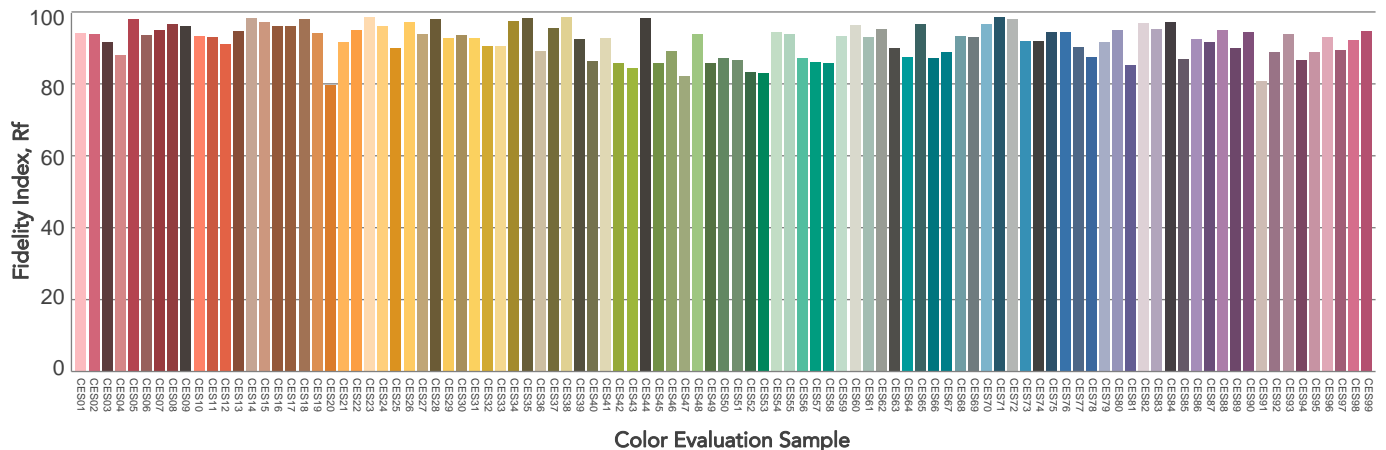
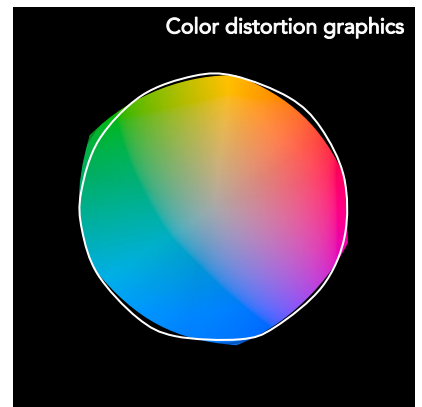
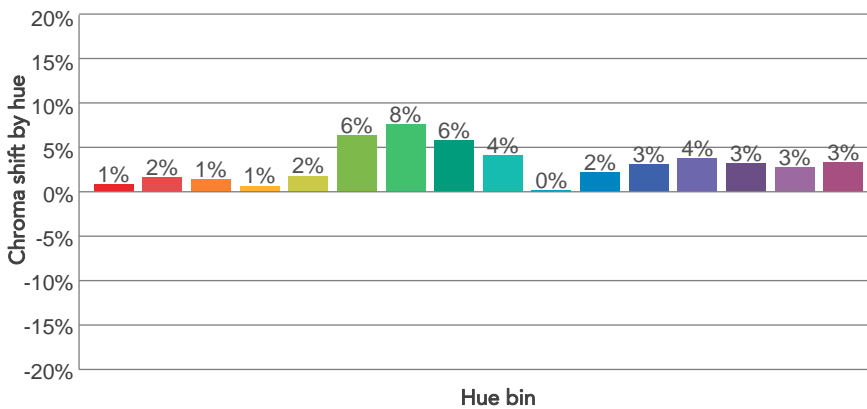
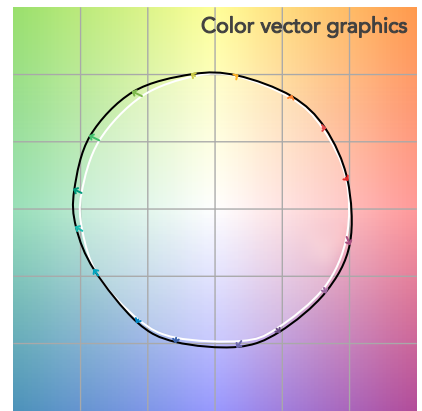
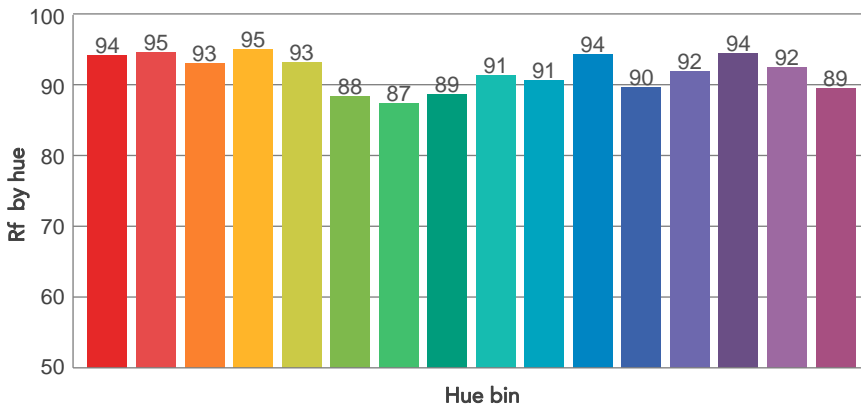
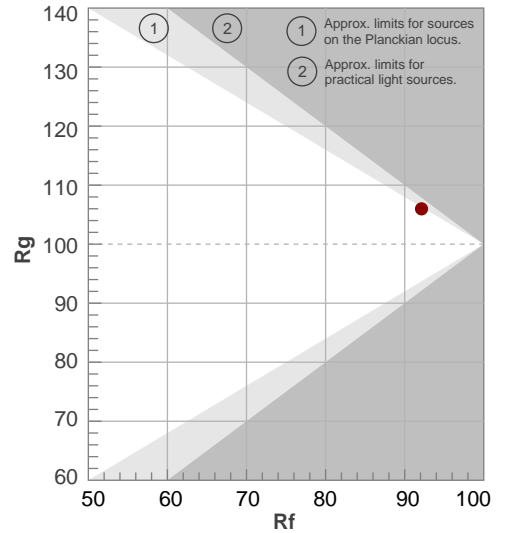

BEAM DETAILS



Beam angle 50%	Field angle 10%	Cut off angle 2,5%	Intensity ratio in 120° cone	Intensity ratio in 90° cone
37°	41,8°	42,8°	100,0%	100,0%

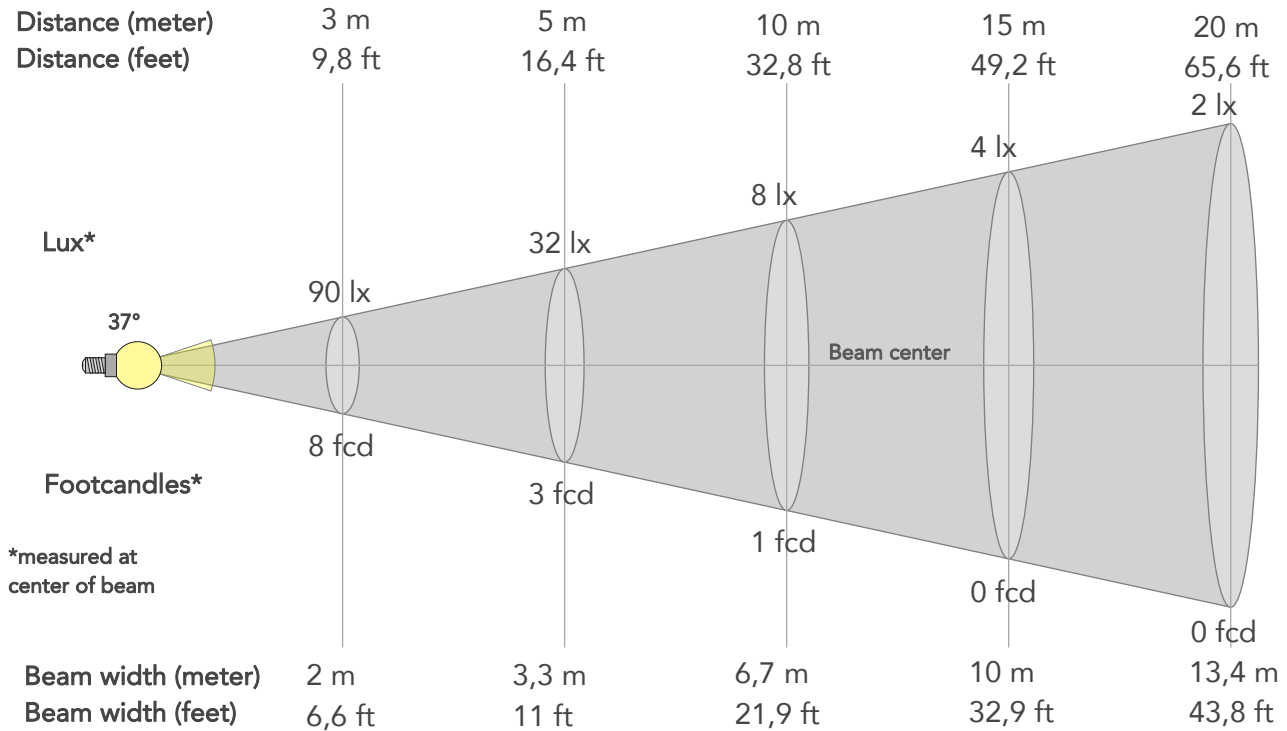

BEAM INTENSITIES AND WIDTHS

Distance	1m	2m	3m	4m	5m	7,5m	10m	15m	20m	25m	30m	40m	50m
Distance	3,3ft	6,6ft	9,8ft	13,1ft	16,4ft	24,6ft	32,8ft	49,2ft	65,6ft	82ft	98,4ft	131,2ft	164ft
Lux	810lx	202lx	90lx	51lx	32lx	14lx	8lx	4lx	2lx	1lx	1lx	1lx	0lx
Footcand.	75fcd	19fcd	8fcd	5fcd	3fcd	1fcd	1fcd	0fcd	0fcd	0fcd	0fcd	0fcd	0fcd
Beam wid.	0,7m	1,3m	2m	2,7m	3,3m	5m	6,7m	10m	13,4m	16,7m	20,1m	26,7m	33,4m
Beam wid.	2,2ft	4,4ft	6,6ft	8,8ft	11ft	16,4ft	21,9ft	32,9ft	43,8ft	54,8ft	65,8ft	87,7ft	109,6ft

LINEAR DISTRIBUTION DIAGRAM

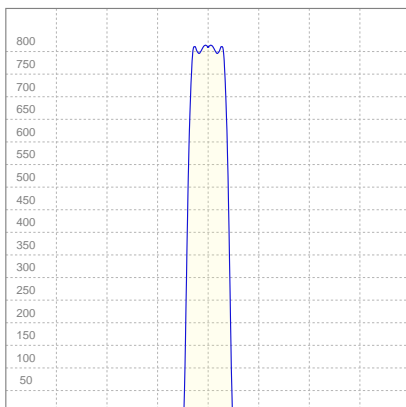

ELECTRICAL SPECIFICATIONS

Input voltage	Input current	Input power	Effeciency
224V	0,116A	23,8W	11lm/W

ISO CANDELA DIAGRAM

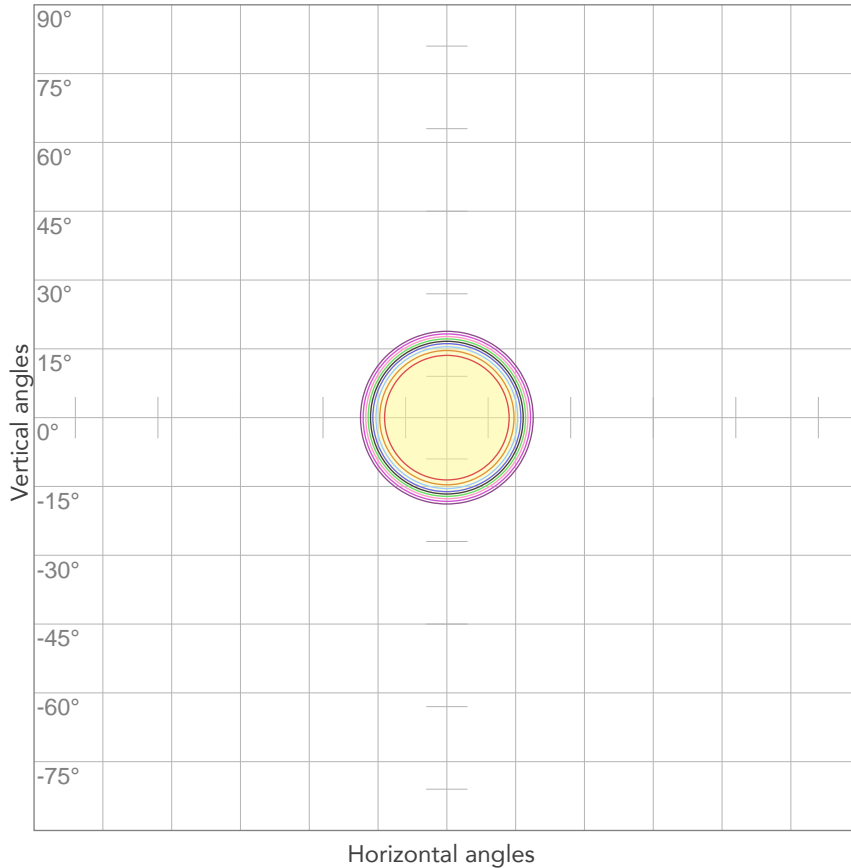

10%	81 cd
20%	162 cd
30%	243 cd
40%	324 cd
50%	405 cd
60%	486 cd
70%	567 cd
80%	648 cd

Conditions:

Number of c-planes: 2
Candela at center: 810 cd

ISO LUX DIAGRAM

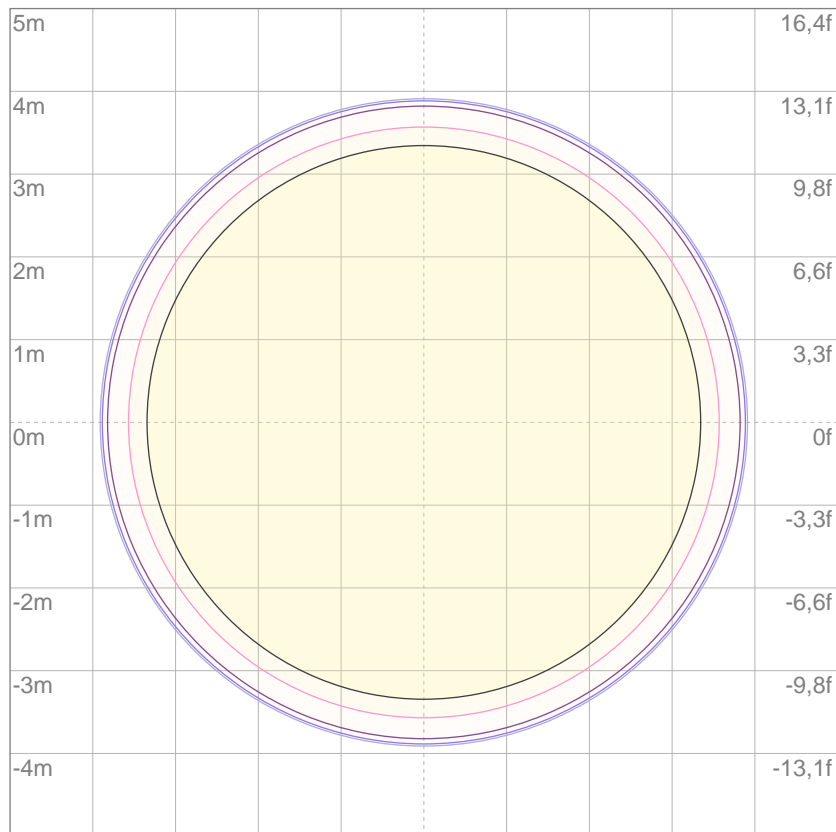

3%	0,243 lx
5%	0,405 lx
10%	0,810 lx
30%	2,43 lx
50%	4,05 lx

Conditions:

Number of c-planes: 2
Lux at center: 8,10 lx

Lux distribution on a surface when lamp is mounted at 10 meters from the surface.

Mounting height: 10 meters (33 feet)



Total lumen output:

288 lm

Peak candela output:

3909 cd

Light quality:

CRI: 93,5

Color temperature:

3938 K

PRODUCT NAME:

ECLDISPLAYFC

MEASURAMENT CONDITIONS:

Beam angle:

Profile Min Zoom

Target:

4000K

Operator:

Paolo Carvone

Date and time:

14/01/2021 11:21:26

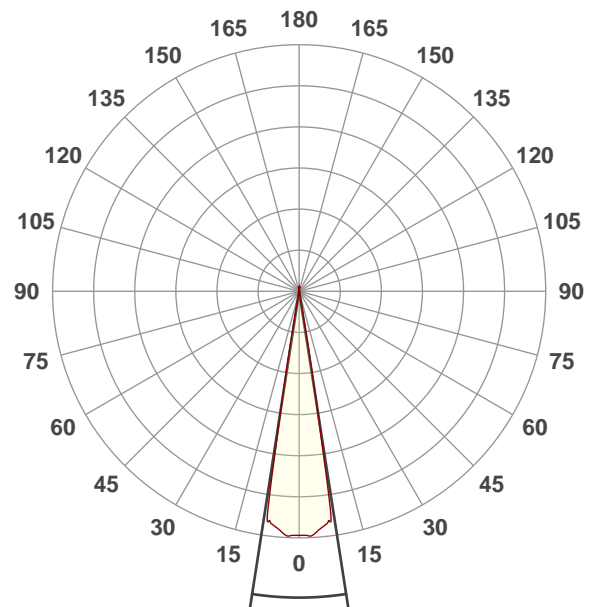

Spectra

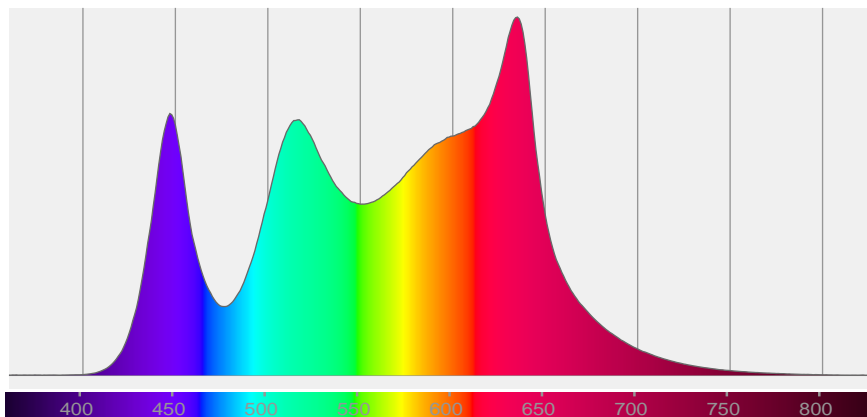

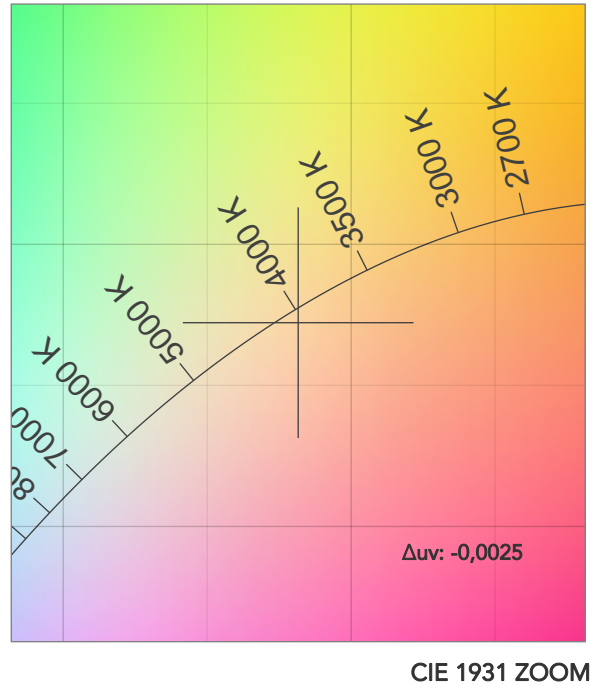
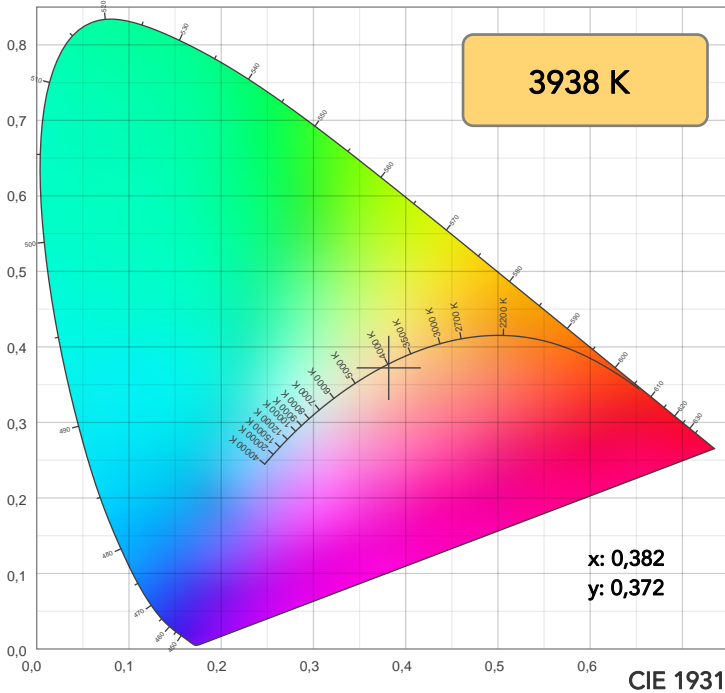

TM30: 92,0

CRI: 93,5 (R1-R8)

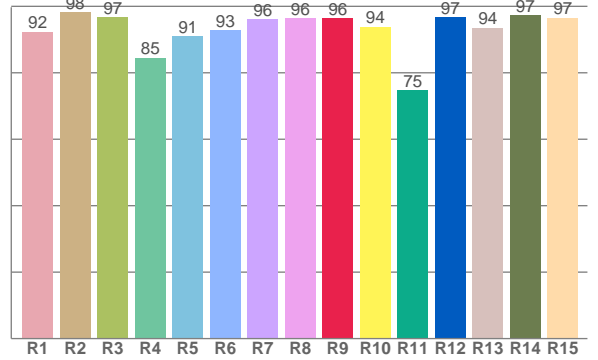
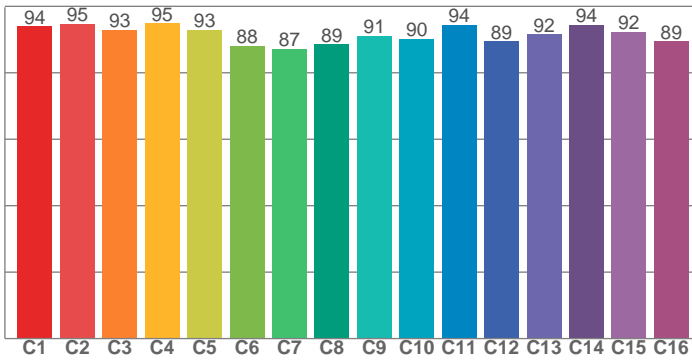

CRI R values, only R1-R8 are used to calculate final CRI value

R1	R2	R3	R4	R5	R6	R7	R8	R9	R10	R11	R12	R13	R14	R15
92,3	98,1	96,7	84,5	91,0	92,8	96,1	96,4	96,4	93,8	74,8	96,7	93,5	97,2	96,6

TM30 C values, 16 binned values out of total of 99 C values

C1	C2	C3	C4	C5	C6	C7	C8	C9	C10	C11	C12	C13	C14	C15	C16
94,0	94,7	92,9	94,9	93,0	88,2	87,1	88,6	91,1	90,2	94,3	89,4	91,6	94,4	92,3	89,4

CQS Q values

Q1	Q2	Q3	Q4	Q5	Q6	Q7	Q8	Q9	Q10	Q11	Q12	Q13	Q14	Q15
96,5	99,4	97,2	92,5	87,6	87,2	97,2	96,7	98,6	99,1	93,6	95,1	97,2	97,5	98,7

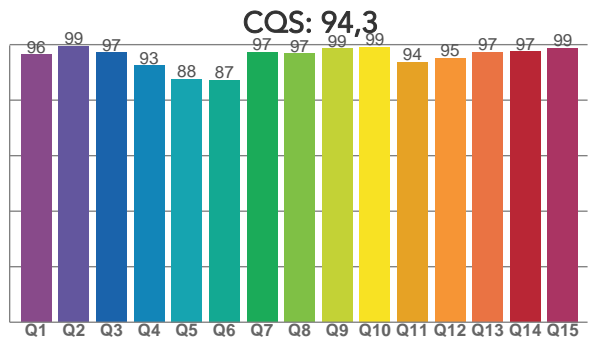

COLOR PARAMETERS

Color temperature	Color rendering index	Red component	Color fidelity	Color gamut	Color quality scale	Television lighting index	Color coordinate cie 1931	Color coordinate cie 1931	Color deviation from black body
CCT	CRI	CRI R9	TM30 Rf	TM30 Rg	CQS	TLCI	x	y	Δuv
3938 K	93,5	96,4	92,0	106,0	94,3	79	0,382	0,372	-0,0025

TM30 DETAILS

Rf 92,0
Fidelity index Rf

Rg 106,0
Gammut index

Hue Bin	R _f	Graphic shifts (%)	
		Chroma	Hue
1	94	1%	-2%
2	95	2%	-1%
3	93	1%	1%
4	95	1%	-1%
5	93	2%	2%
6	88	6%	4%
7	87	8%	1%
8	89	6%	-2%
9	91	4%	-4%
10	90	0%	-5%
11	94	2%	0%
12	89	3%	0%
13	92	4%	-4%
14	94	3%	0%
15	92	3%	-2%
16	89	3%	-5%

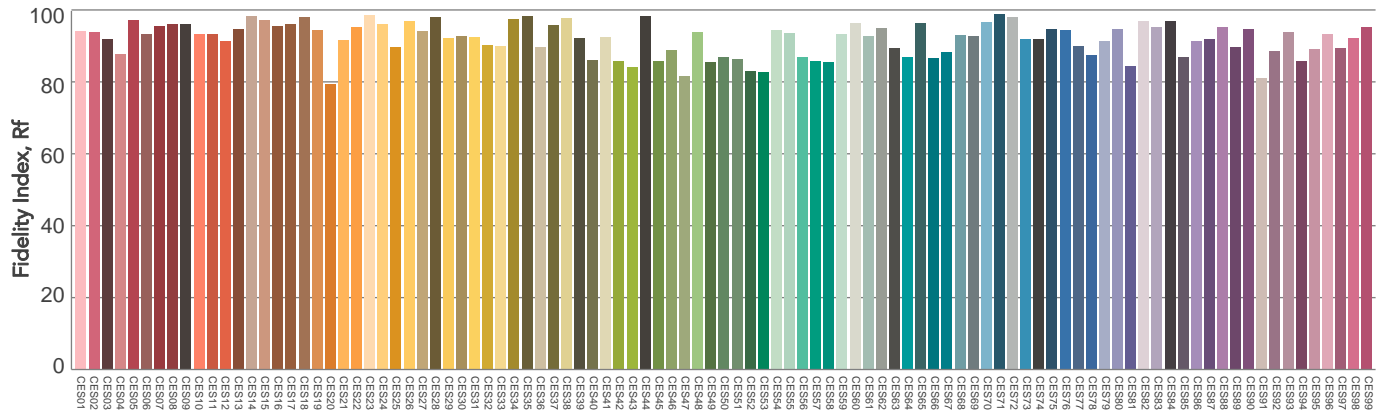
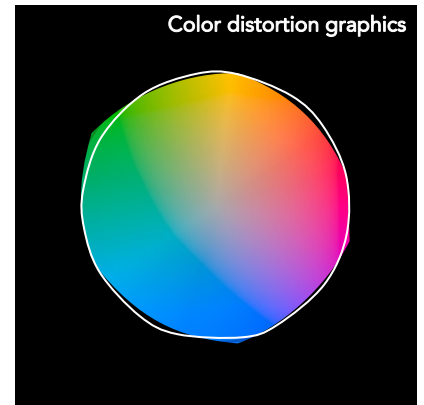
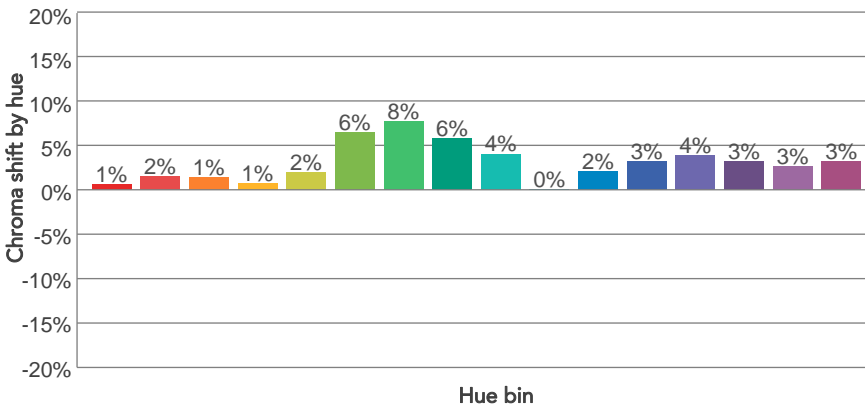
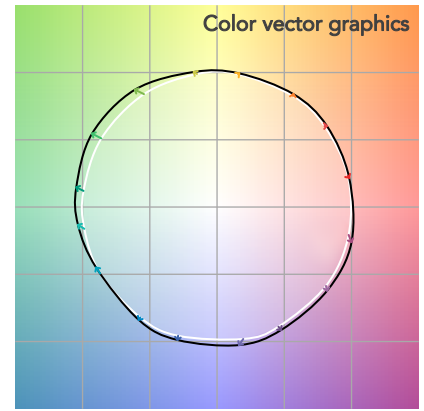
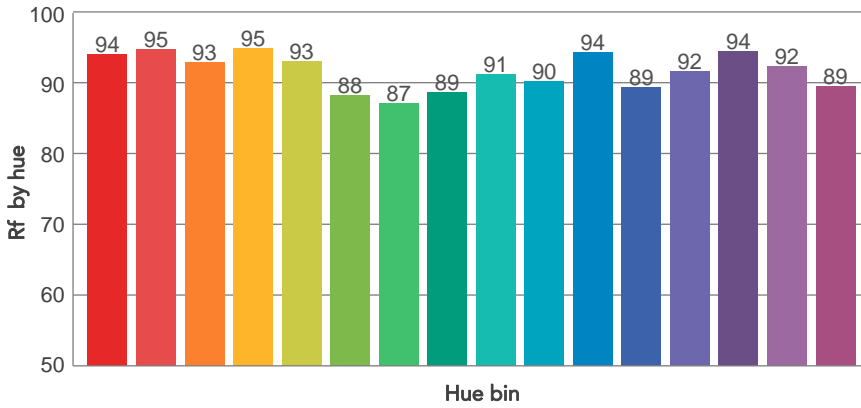
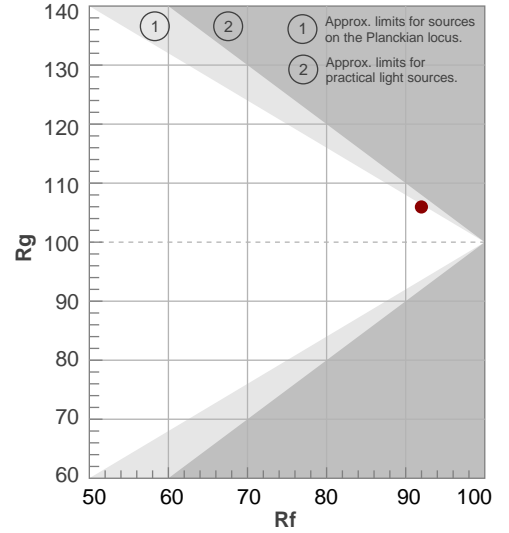

Color Evaluation Sample

BEAM DETAILS



Beam angle 50%	Field angle 10%	Cut off angle 2,5%	Intensity ratio in 120° cone	Intensity ratio in 90° cone
17,6°	19,5°	20°	100,0%	100,0%

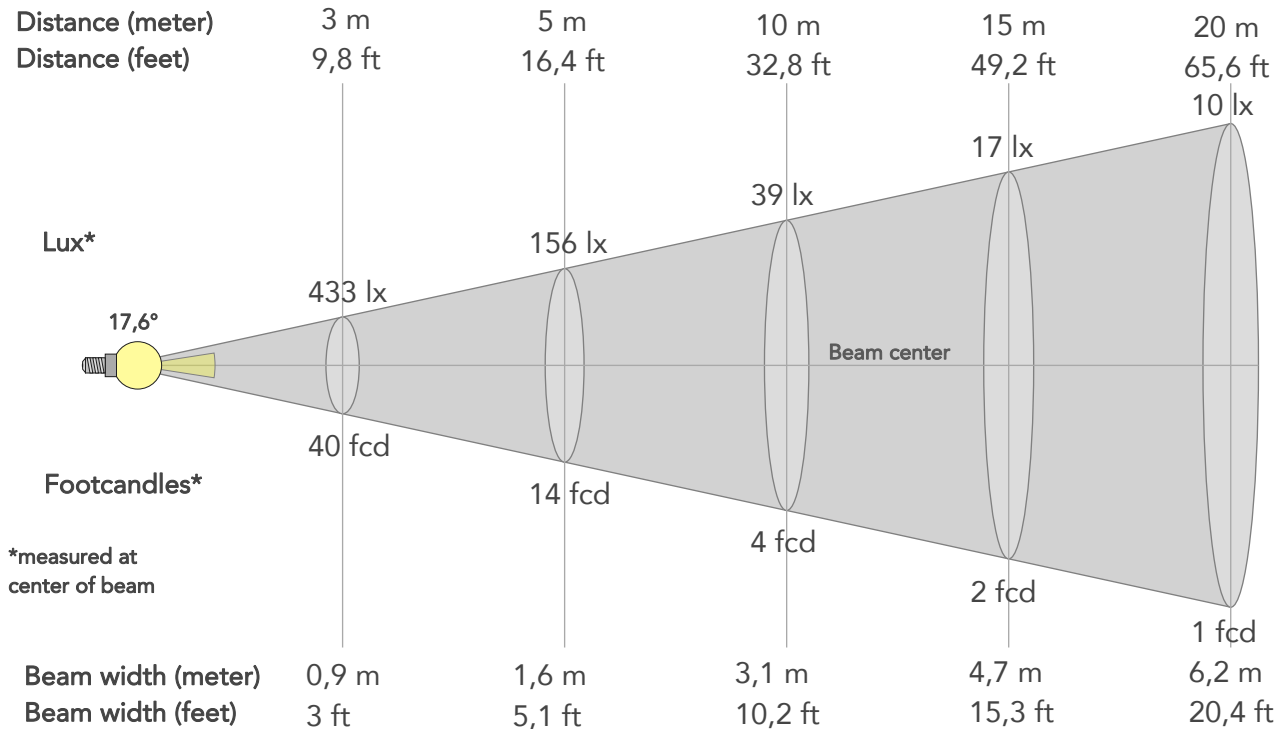

BEAM INTENSITIES AND WIDTHS

Distance	1m	2m	3m	4m	5m	7,5m	10m	15m	20m	25m	30m	40m	50m
Distance	3,3ft	6,6ft	9,8ft	13,1ft	16,4ft	24,6ft	32,8ft	49,2ft	65,6ft	82ft	98,4ft	131,2ft	164ft
Lux	3894lx	973lx	433lx	243lx	156lx	69lx	39lx	17lx	10lx	6lx	4lx	2lx	2lx
Footcand.	362fcd	90fcd	40fcd	23fcd	14fcd	6fcd	4fcd	2fcd	1fcd	1fcd	0fcd	0fcd	0fcd
Beam wid.	0,3m	0,6m	0,9m	1,2m	1,6m	2,3m	3,1m	4,7m	6,2m	7,8m	9,3m	12,4m	15,5m
Beam wid.	1ft	2ft	3ft	4,1ft	5,1ft	7,6ft	10,2ft	15,3ft	20,4ft	25,5ft	30,6ft	40,7ft	50,9ft

LINEAR DISTRIBUTION DIAGRAM

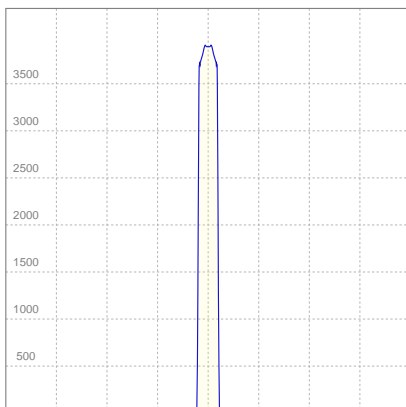

ELECTRICAL SPECIFICATIONS

Input voltage	Input current	Input power	Effeciency
224V	0,117A	23,9W	12lm/W

ISO CANDELA DIAGRAM

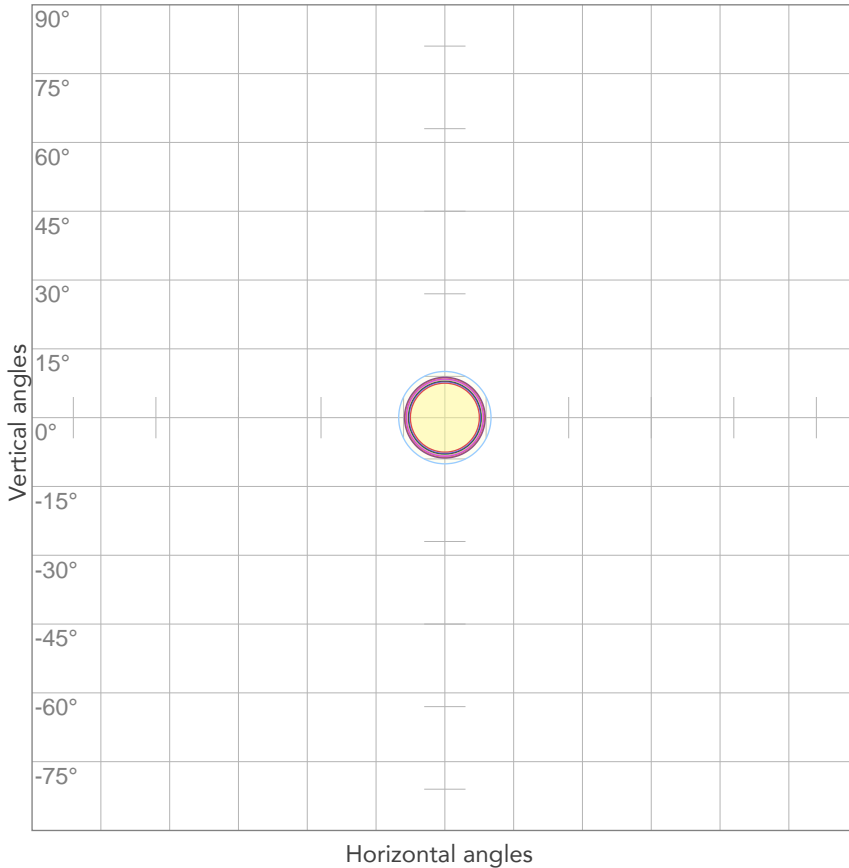

10%	389 cd
20%	779 cd
30%	1168 cd
40%	1558 cd
50%	1947 cd
60%	2336 cd
70%	2726 cd
80%	3115 cd

Conditions:

Number of c-planes: 2

Candela at center: 3894 cd

ISO LUX DIAGRAM

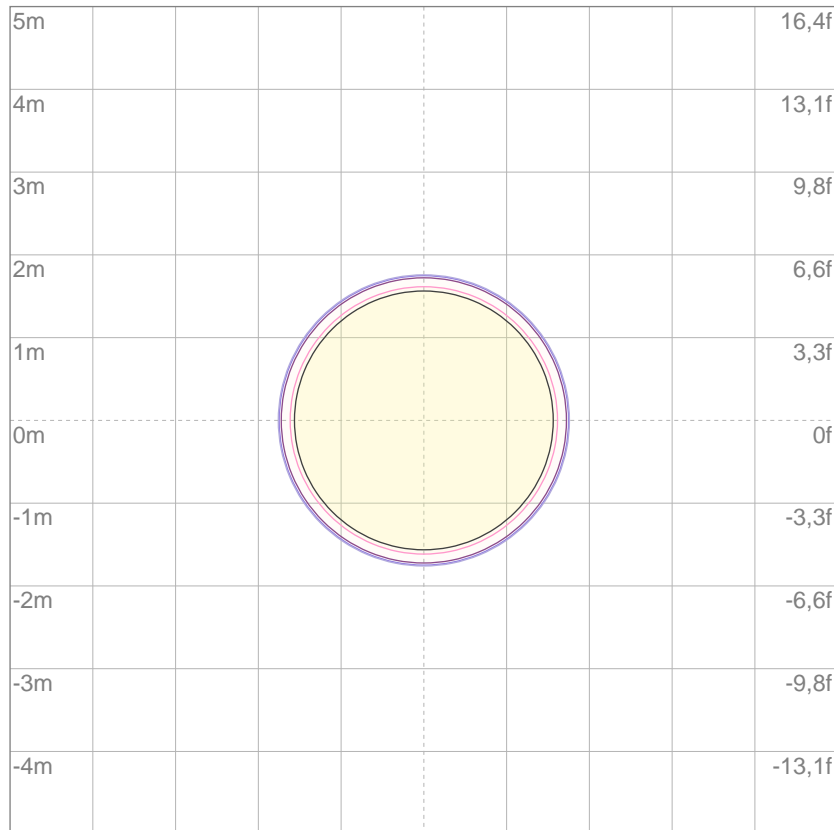

3%	1,17 lx
5%	1,95 lx
10%	3,89 lx
30%	11,7 lx
50%	19,5 lx

Conditions:

Number of c-planes: 2

Lux at center: 38,9 lx

Lux distribution on a surface when lamp is mounted at 10 meters from the surface.

Mounting height: 10 meters (33 feet)



Total lumen output:

280 lm

Peak candela output:

881 cd

Light quality:

CRI: 91,2

Color temperature:

5620 K

PRODUCT NAME:

ECLDISPLAYFC

MEASUREMENT CONDITIONS:

Beam angle:

Profile Max Zoom

Target:

5600K

Operator:

Paolo Carvone

Date and time:

14/01/2021 11:36:00

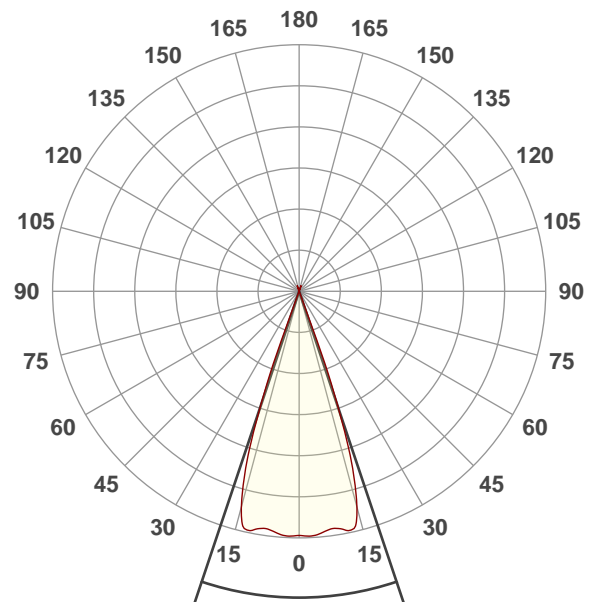

Beam angle 50%: 37,1°

Field angle 10%: 41,6°

Cut off angle 2.5%: 42,4°

Spectra

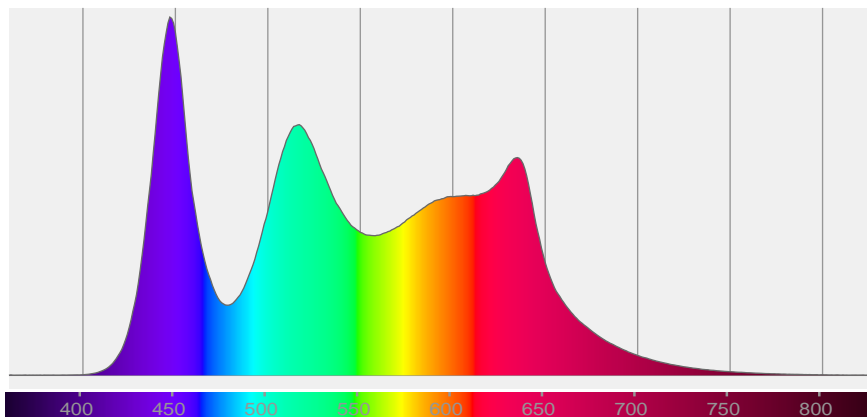

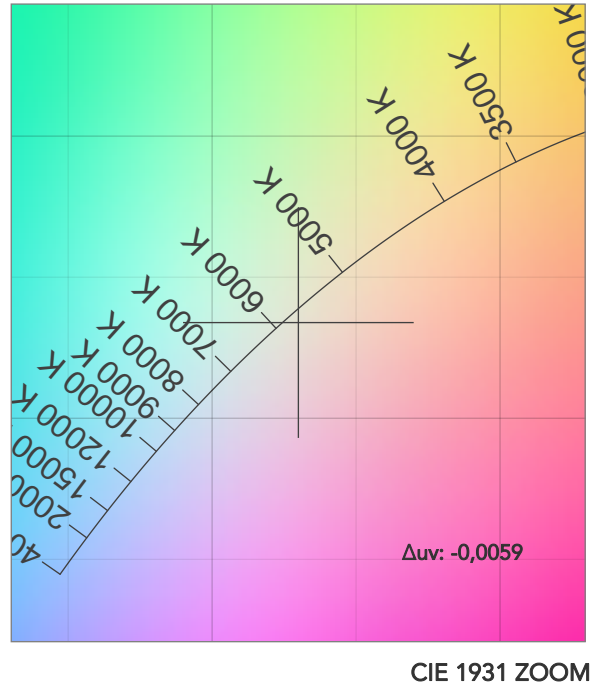
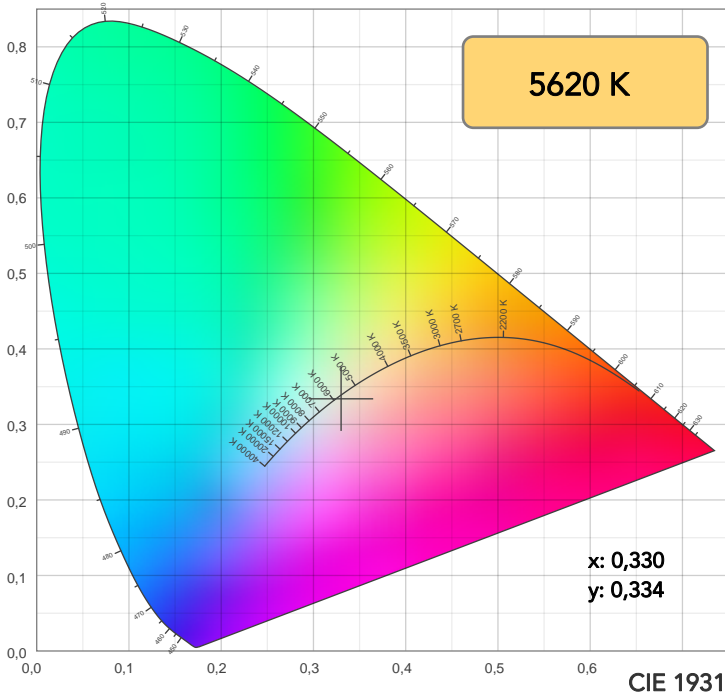

TM30: 90,4

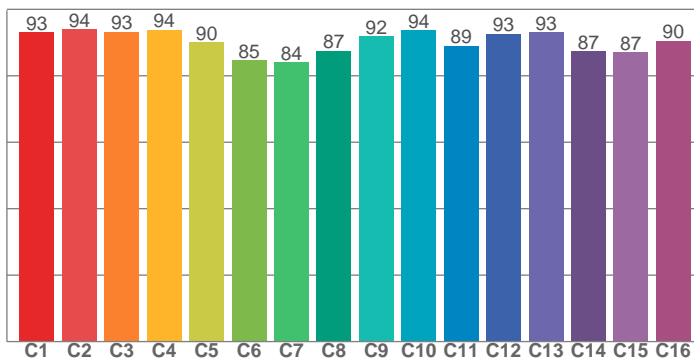

CRI: 91,2 (R1-R8)

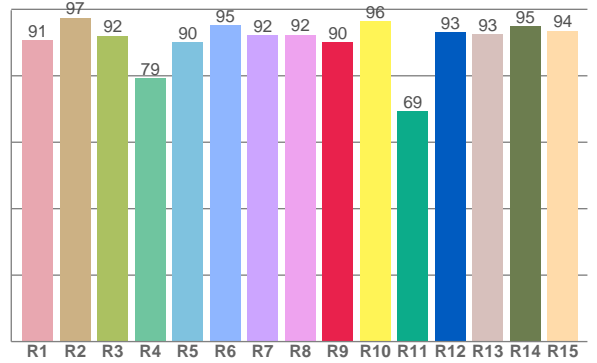

CRI R values, only R1-R8 are used to calculate final CRI value

R1	R2	R3	R4	R5	R6	R7	R8	R9	R10	R11	R12	R13	R14	R15
90,6	97,4	92,1	79,3	90,1	95,2	92,2	92,3	90,1	96,5	69,4	93,0	92,5	94,8	93,5

TM30 C values, 16 binned values out of total of 99 C values

C1	C2	C3	C4	C5	C6	C7	C8	C9	C10	C11	C12	C13	C14	C15	C16
93,1	93,9	93,2	93,8	90,1	84,7	84,1	87,4	91,8	93,7	89,0	92,7	93,1	87,4	87,1	90,5

CQS Q values

Q1	Q2	Q3	Q4	Q5	Q6	Q7	Q8	Q9	Q10	Q11	Q12	Q13	Q14	Q15
97,7	96,0	90,8	96,1	87,8	86,9	97,7	94,6	95,3	96,3	96,1	97,1	98,2	97,1	98,7

CQS: 94,0

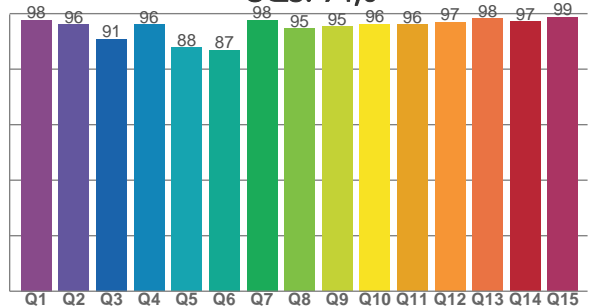

COLOR PARAMETERS

Color temperature	Color rendering index	Red component	Color fidelity	Color gamut	Color quality scale	Television lighting index	Color coordinate cie 1931	Color coordinate cie 1931	Color deviation from black body
CCT	CRI	CRI R9	TM30 Rf	TM30 Rg	CQS	TLCI	x	y	Δuv
5620 K	91,2	90,1	90,4	108,3	94,0	81	0,330	0,334	-0,0059

TM30 DETAILS

Rf 90,4
Fidelity index Rf

Rg 108,3
Gammut index

Hue Bin	R _f	Graphic shifts (%)	
		Chroma	Hue
1	93	2%	-2%
2	94	2%	0%
3	93	2%	2%
4	94	2%	2%
5	90	3%	3%
6	85	9%	5%
7	84	10%	1%
8	87	6%	-3%
9	92	3%	-5%
10	94	0%	-3%
11	89	1%	6%
12	93	2%	3%
13	93	5%	2%
14	87	5%	4%
15	87	10%	-4%
16	90	5%	-1%

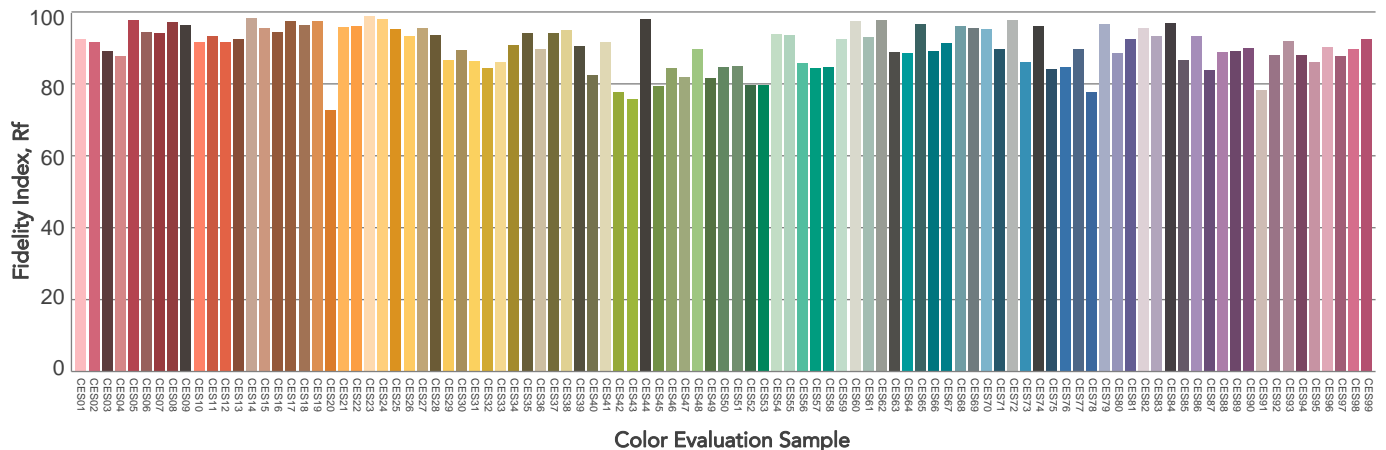
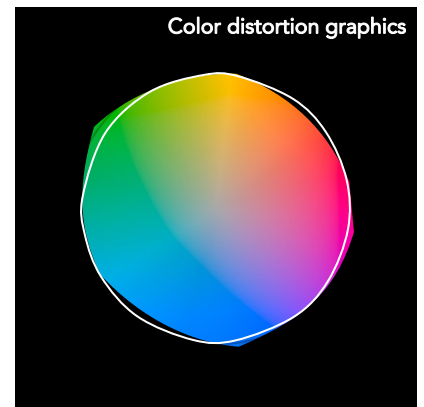
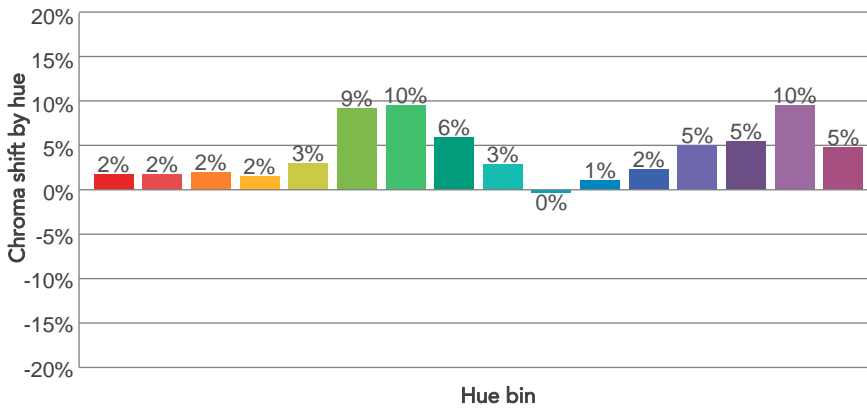
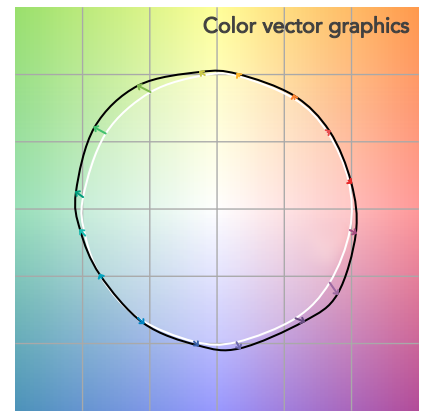
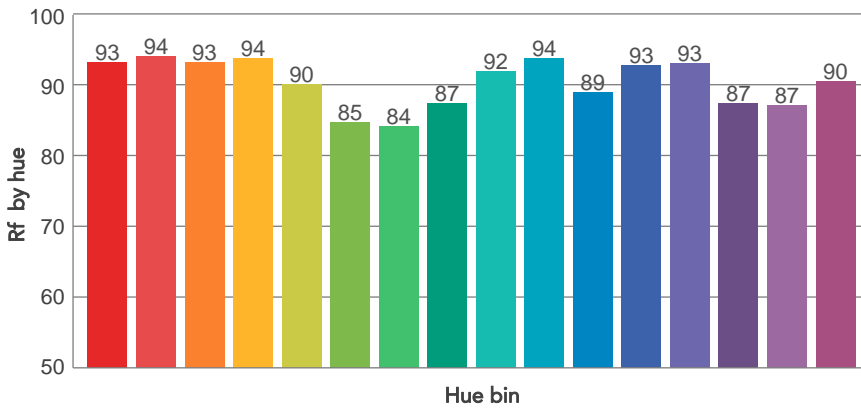
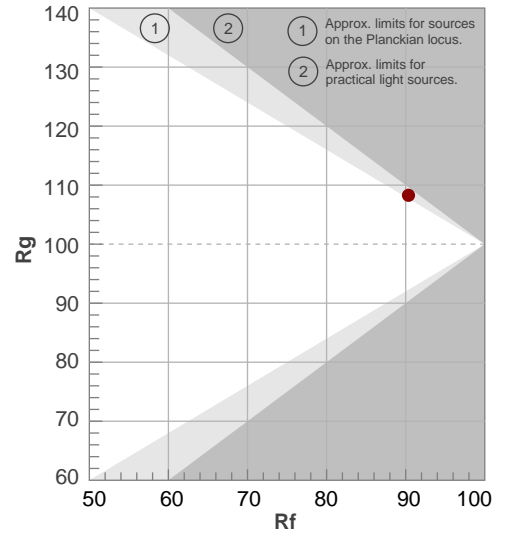

BEAM DETAILS



Beam angle 50%	Field angle 10%	Cut off angle 2,5%	Intensity ratio in 120° cone	Intensity ratio in 90° cone
37,1°	41,6°	42,4°	100,0%	100,0%

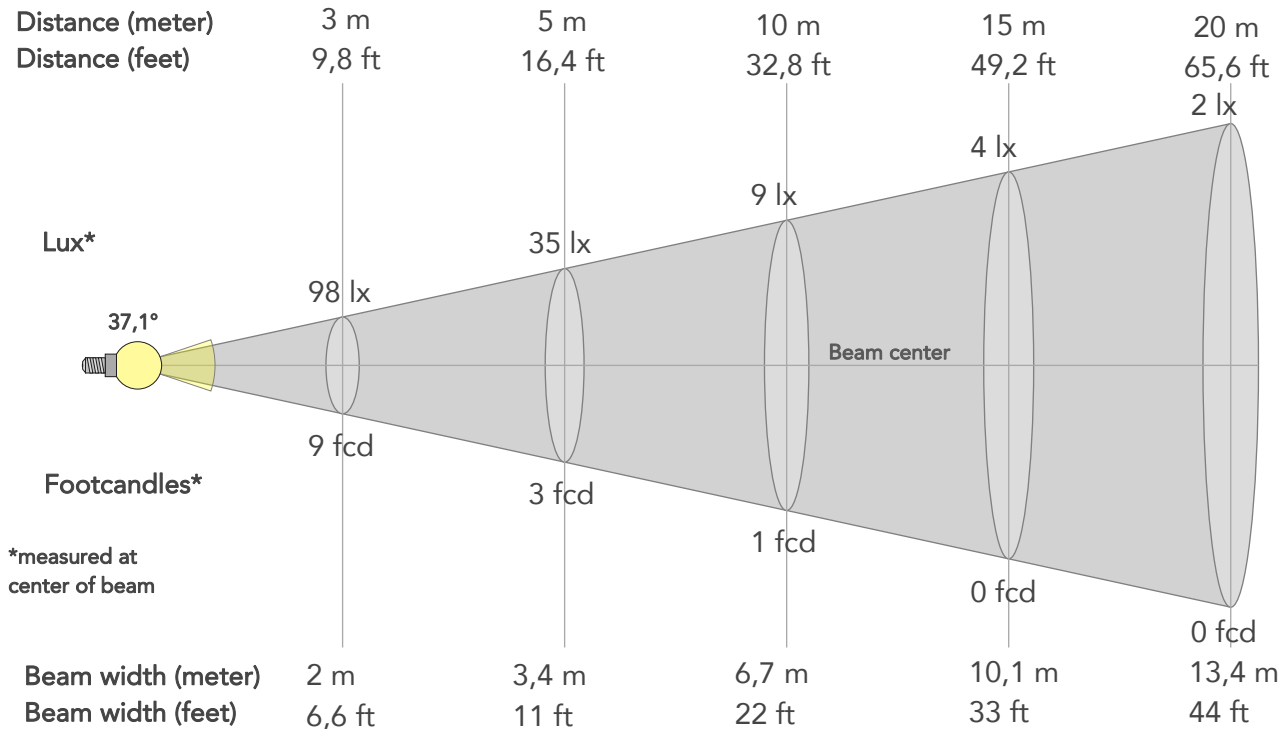

BEAM INTENSITIES AND WIDTHS

Distance	1m	2m	3m	4m	5m	7,5m	10m	15m	20m	25m	30m	40m	50m
Distance	3,3ft	6,6ft	9,8ft	13,1ft	16,4ft	24,6ft	32,8ft	49,2ft	65,6ft	82ft	98,4ft	131,2ft	164ft
Lux	878lx	220lx	98lx	55lx	35lx	16lx	9lx	4lx	2lx	1lx	1lx	1lx	0lx
Footcand.	82fcd	20fcd	9fcd	5fcd	3fcd	1fcd	1fcd	0fcd	0fcd	0fcd	0fcd	0fcd	0fcd
Beam wid.	0,7m	1,3m	2m	2,7m	3,4m	5m	6,7m	10,1m	13,4m	16,8m	20,1m	26,8m	33,6m
Beam wid.	2,2ft	4,4ft	6,6ft	8,8ft	11ft	16,5ft	22ft	33ft	44ft	55ft	66ft	88ft	110ft

LINEAR DISTRIBUTION DIAGRAM

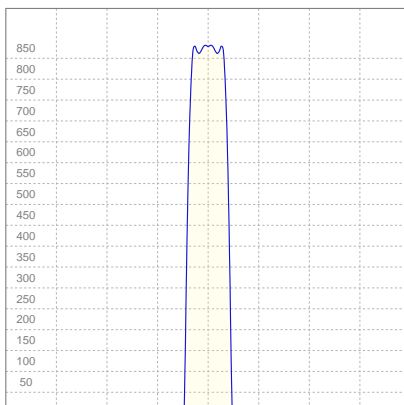

ELECTRICAL SPECIFICATIONS

Input voltage	Input current	Input power	Effeciency
223V	0,127A	26,2W	11lm/W

ISO CANDELA DIAGRAM

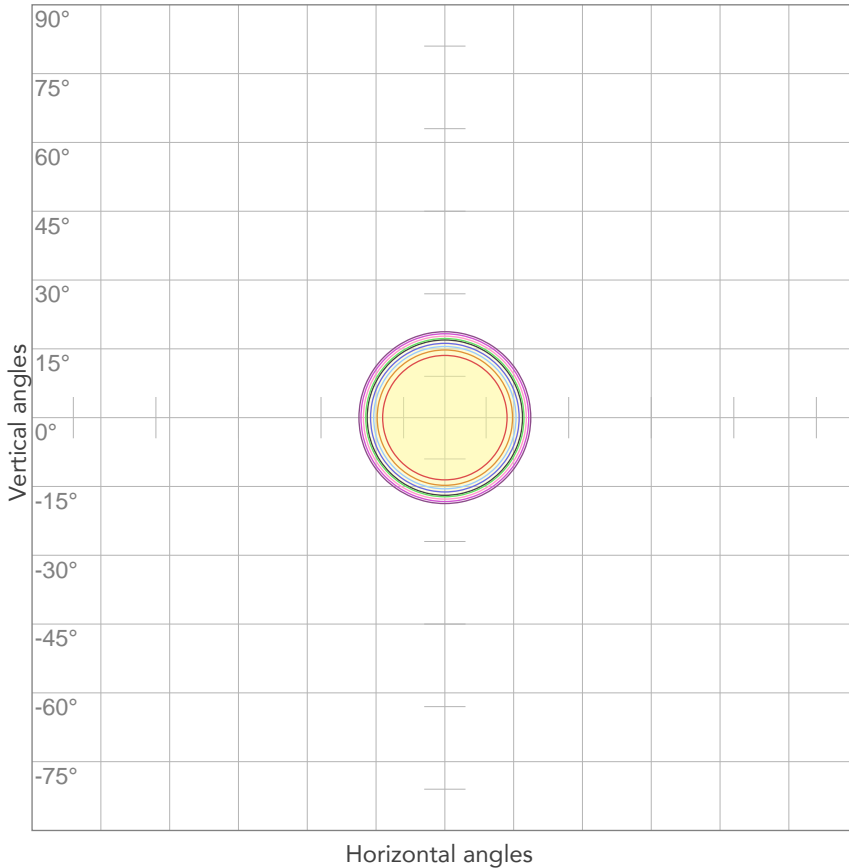

10%	88 cd
20%	176 cd
30%	264 cd
40%	351 cd
50%	439 cd
60%	527 cd
70%	615 cd
80%	703 cd

Conditions:

Number of c-planes: 2

Candela at center: 878 cd

ISO LUX DIAGRAM

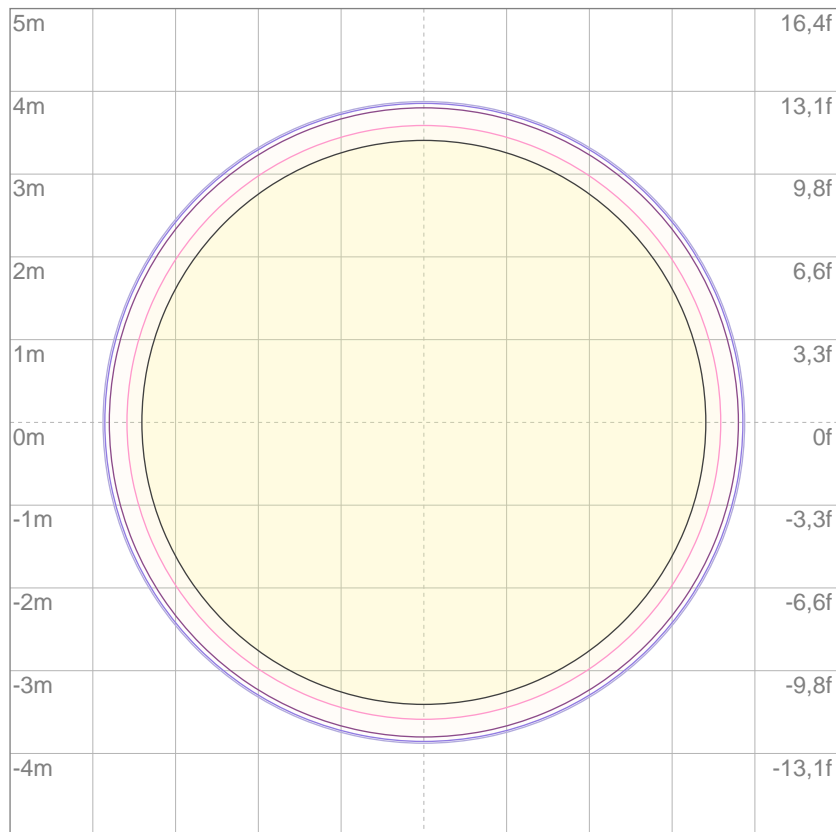

3%	0,264 lx
5%	0,439 lx
10%	0,878 lx
30%	2,64 lx
50%	4,39 lx

Conditions:

Number of c-planes: 2

Lux at center: 8,78 lx

Lux distribution on a surface when lamp is mounted at 10 meters from the surface.

Mounting height: 10 meters (33 feet)



Total lumen output:

314 lm

Peak candela output:

4213 cd

Light quality:

CRI: 91,0

Color temperature:

5650 K

PRODUCT NAME:

ECLDISPLAYFC

MEASURAMENT CONDITIONS:

Beam angle:

Profile Min Zoom

Target:

5600K

Operator:

Paolo Carvone

Date and time:

14/01/2021 11:25:05

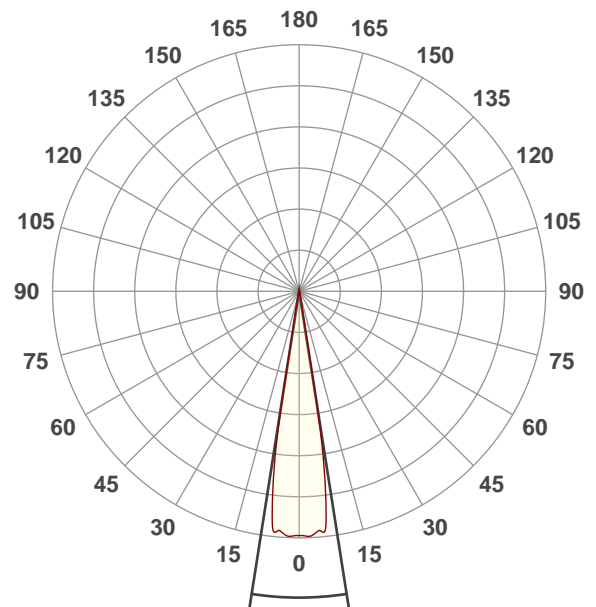

Beam angle 50%: 17,8°

Field angle 10%: 20,5°

Cut off angle 2.5%: 22,9°

Spectra

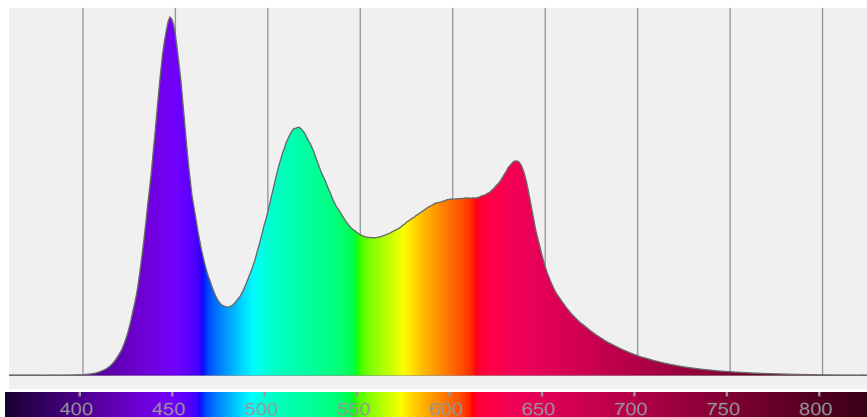

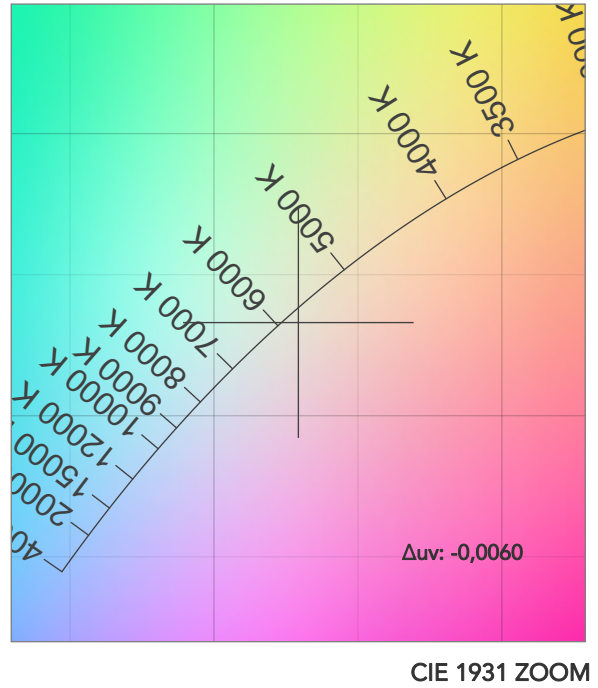
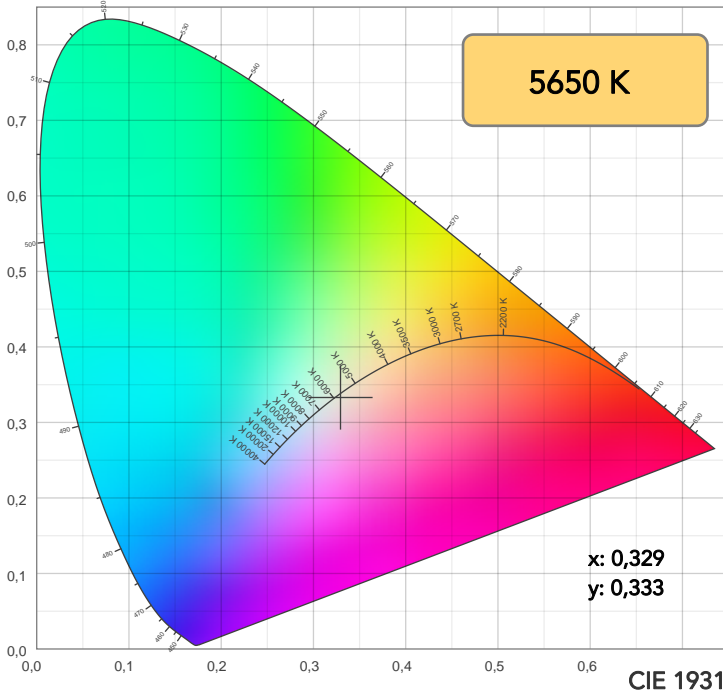

TM30: 90,2

CRI: 91,0 (R1-R8)

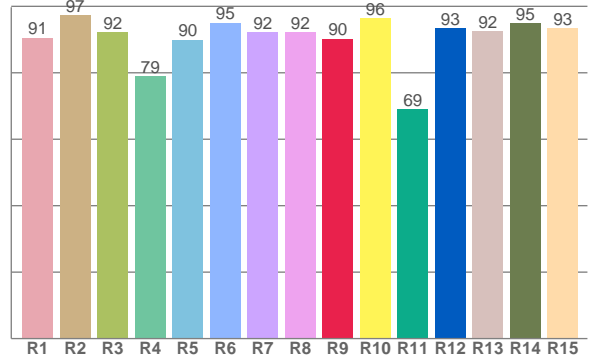
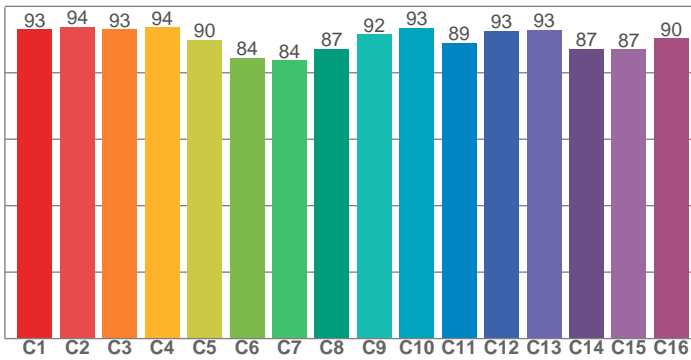

CRI R values, only R1-R8 are used to calculate final CRI value

R1	R2	R3	R4	R5	R6	R7	R8	R9	R10	R11	R12	R13	R14	R15
90,5	97,4	92,1	78,9	90,0	95,1	92,1	92,3	90,2	96,3	69,0	93,4	92,5	94,9	93,4

TM30 C values, 16 binned values out of total of 99 C values

C1	C2	C3	C4	C5	C6	C7	C8	C9	C10	C11	C12	C13	C14	C15	C16
93,0	93,9	93,1	93,6	89,9	84,4	83,8	87,2	91,6	93,5	89,0	92,6	93,0	87,2	87,1	90,4

CQS Q values

Q1	Q2	Q3	Q4	Q5	Q6	Q7	Q8	Q9	Q10	Q11	Q12	Q13	Q14	Q15
97,6	95,9	90,8	95,9	87,5	86,8	97,8	94,5	95,3	96,3	96,1	97,1	98,3	97,1	98,7

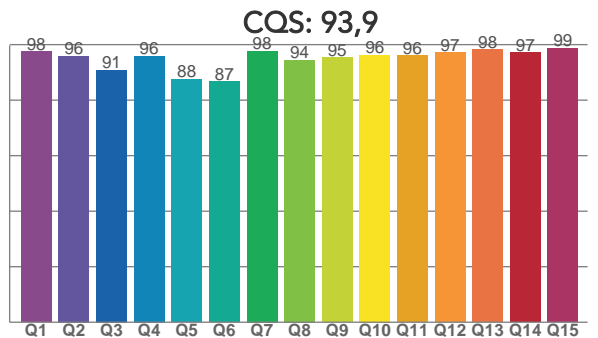

COLOR PARAMETERS

Color temperature	Color rendering index	Red component	Color fidelity	Color gamut	Color quality scale	Television lighting index	Color coordinate cie 1931	Color coordinate cie 1931	Color deviation from black body
CCT	CRI	CRI R9	TM30 Rf	TM30 Rg	CQS	TLCI	x	y	Δuv
5650 K	91,0	90,2	90,2	108,4	93,9	81	0,329	0,333	-0,0060

TM30 DETAILS

Rf 90,2
Fidelity index Rf

Rg 108,4
Gammut index

Hue Bin	R _f	Graphic shifts (%)	
		Chroma	Hue
1	93	2%	-2%
2	94	2%	0%
3	93	2%	2%
4	94	2%	2%
5	90	3%	3%
6	84	9%	5%
7	84	10%	1%
8	87	6%	-3%
9	92	3%	-5%
10	93	0%	-3%
11	89	1%	6%
12	93	2%	3%
13	93	5%	2%
14	87	5%	4%
15	87	10%	-4%
16	90	5%	-1%

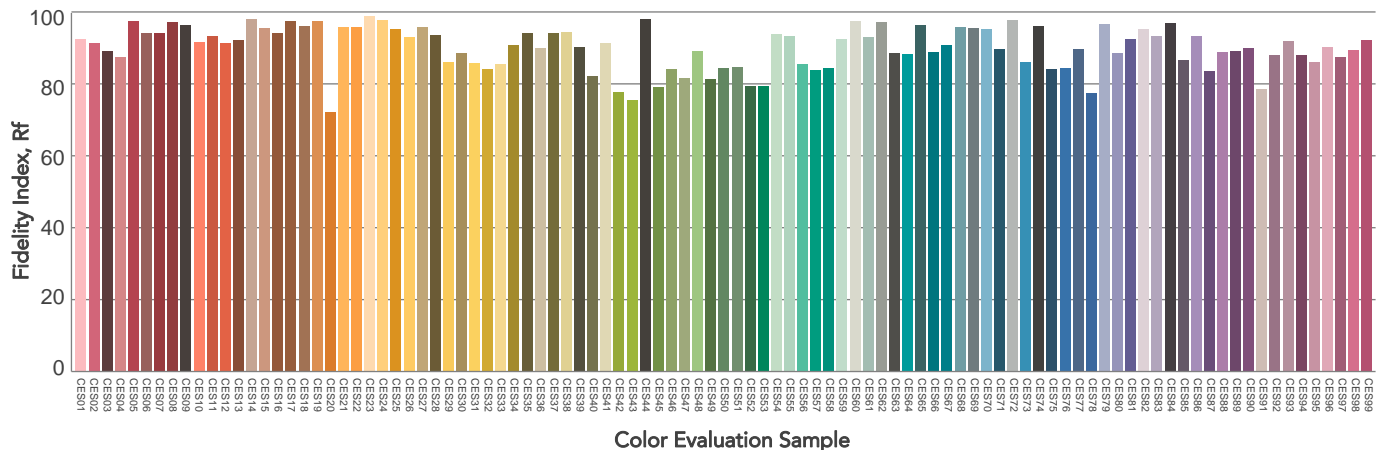
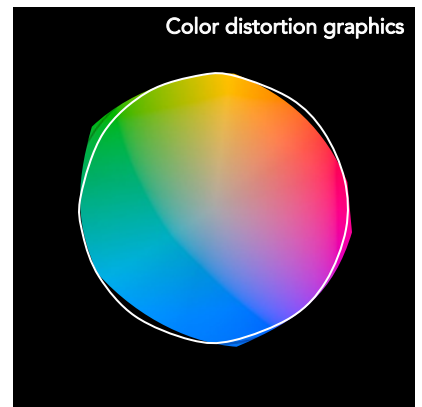
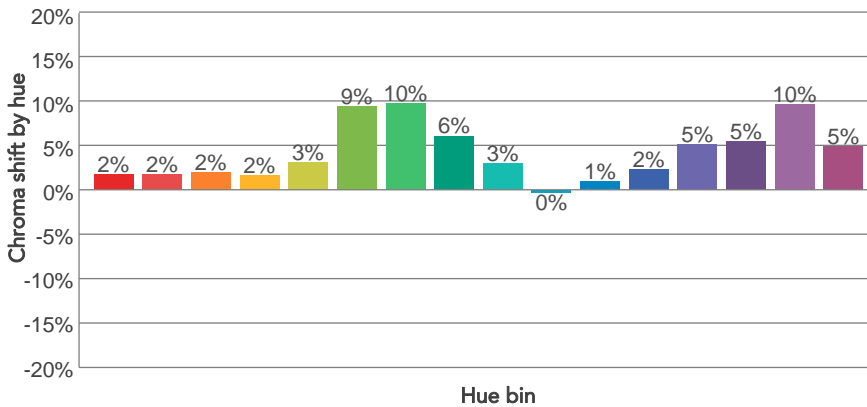
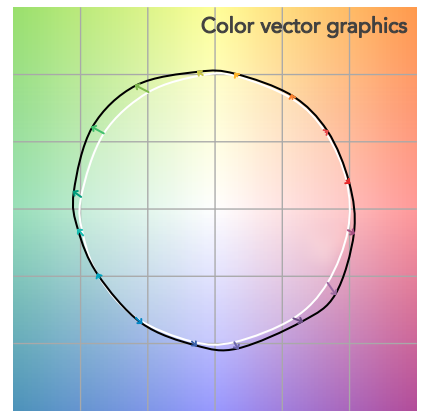
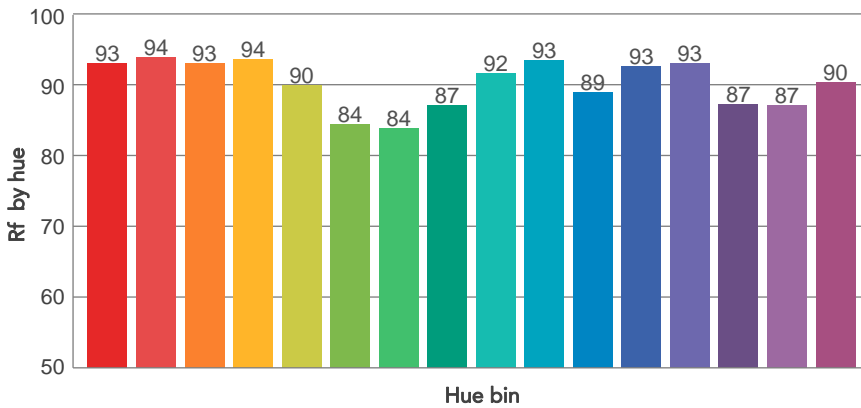
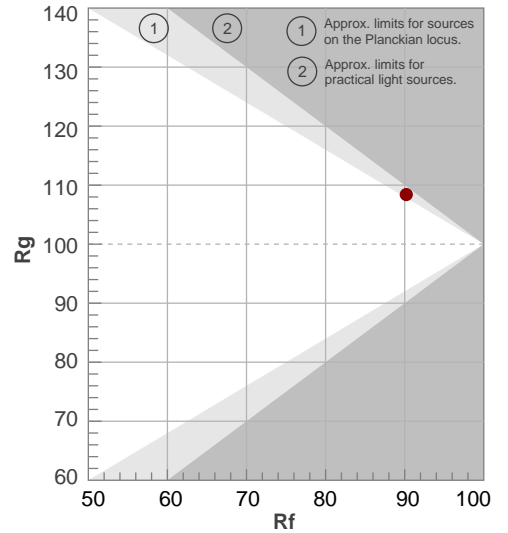

BEAM DETAILS



Beam angle 50%	Field angle 10%	Cut off angle 2,5%	Intensity ratio in 120° cone	Intensity ratio in 90° cone
17,8°	20,5°	22,9°	100,0%	100,0%

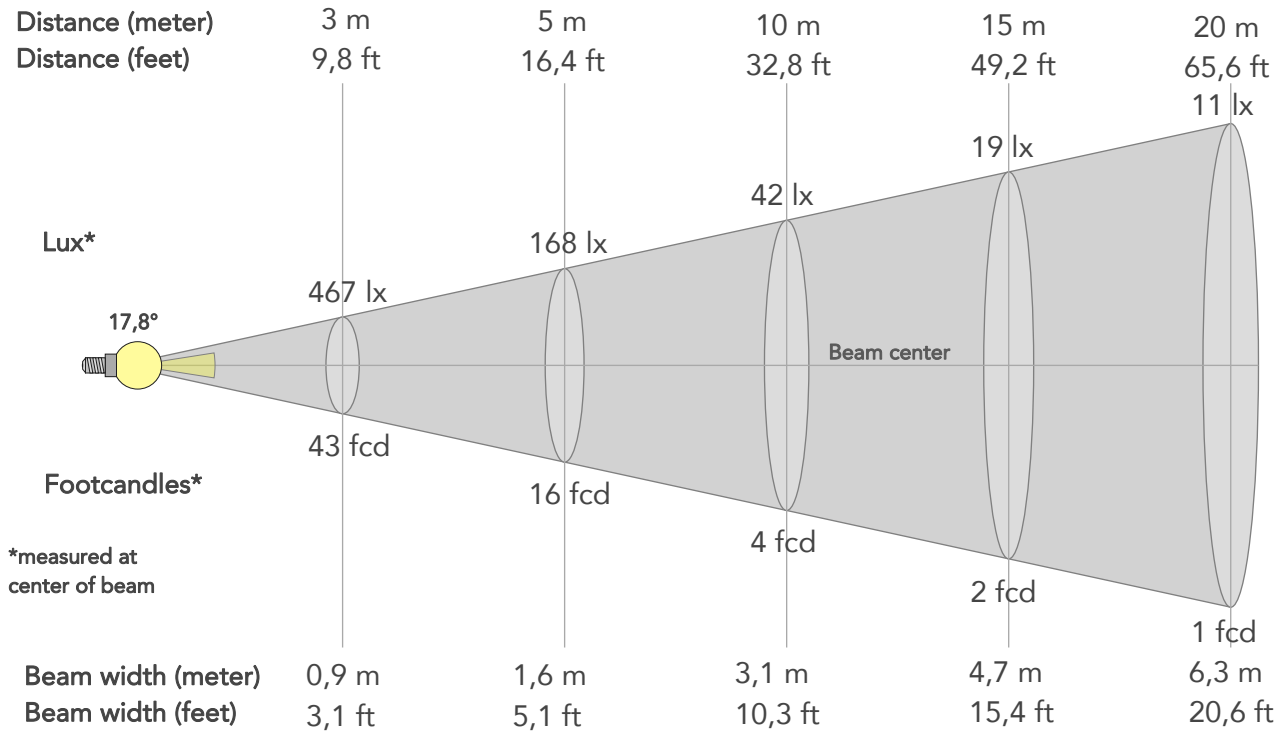

BEAM INTENSITIES AND WIDTHS

Distance	1m	2m	3m	4m	5m	7,5m	10m	15m	20m	25m	30m	40m	50m
Distance	3,3ft	6,6ft	9,8ft	13,1ft	16,4ft	24,6ft	32,8ft	49,2ft	65,6ft	82ft	98,4ft	131,2ft	164ft
Lux	4201lx	1050lx	467lx	263lx	168lx	75lx	42lx	19lx	11lx	7lx	5lx	3lx	2lx
Footcand.	390fcd	98fcd	43fcd	24fcd	16fcd	7fcd	4fcd	2fcd	1fcd	1fcd	0fcd	0fcd	0fcd
Beam wid.	0,3m	0,6m	0,9m	1,3m	1,6m	2,4m	3,1m	4,7m	6,3m	7,8m	9,4m	12,6m	15,7m
Beam wid.	1ft	2,1ft	3,1ft	4,1ft	5,1ft	7,7ft	10,3ft	15,4ft	20,6ft	25,7ft	30,9ft	41,2ft	51,5ft

LINEAR DISTRIBUTION DIAGRAM

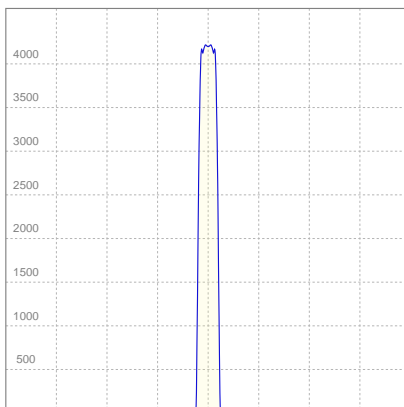

ELECTRICAL SPECIFICATIONS

Input voltage	Input current	Input power	Effeciency
223V	0,127A	26,3W	12lm/W

ISO CANDELA DIAGRAM

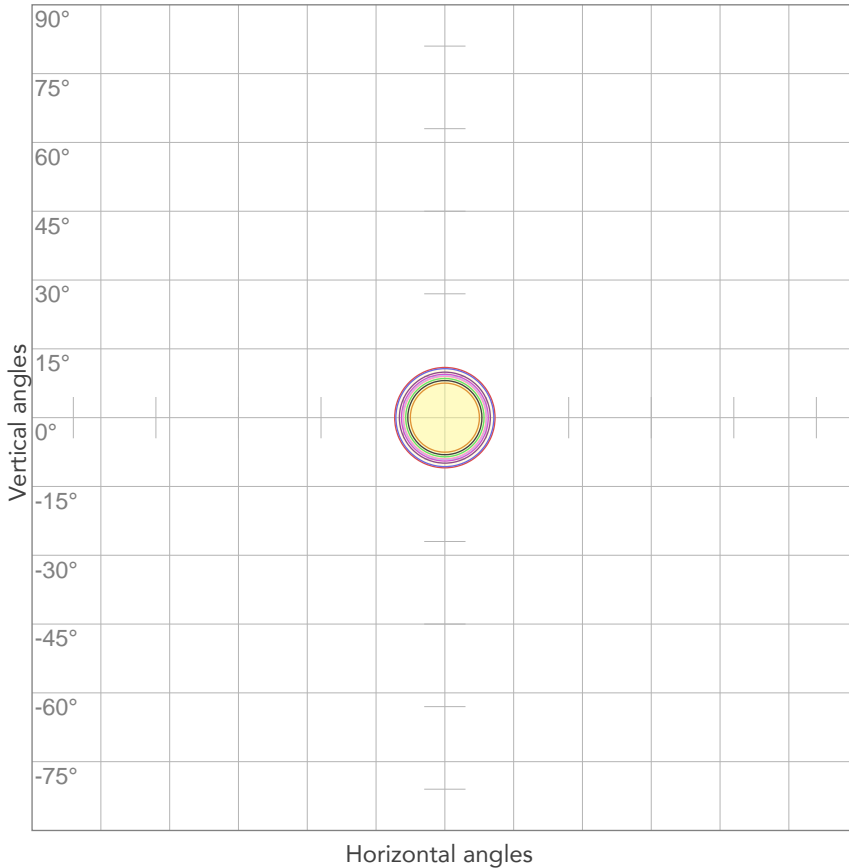

10%	420 cd
20%	840 cd
30%	1260 cd
40%	1680 cd
50%	2100 cd
60%	2520 cd
70%	2940 cd
80%	3360 cd

Conditions:

Number of c-planes: 2

Candela at center: 4201 cd

ISO LUX DIAGRAM

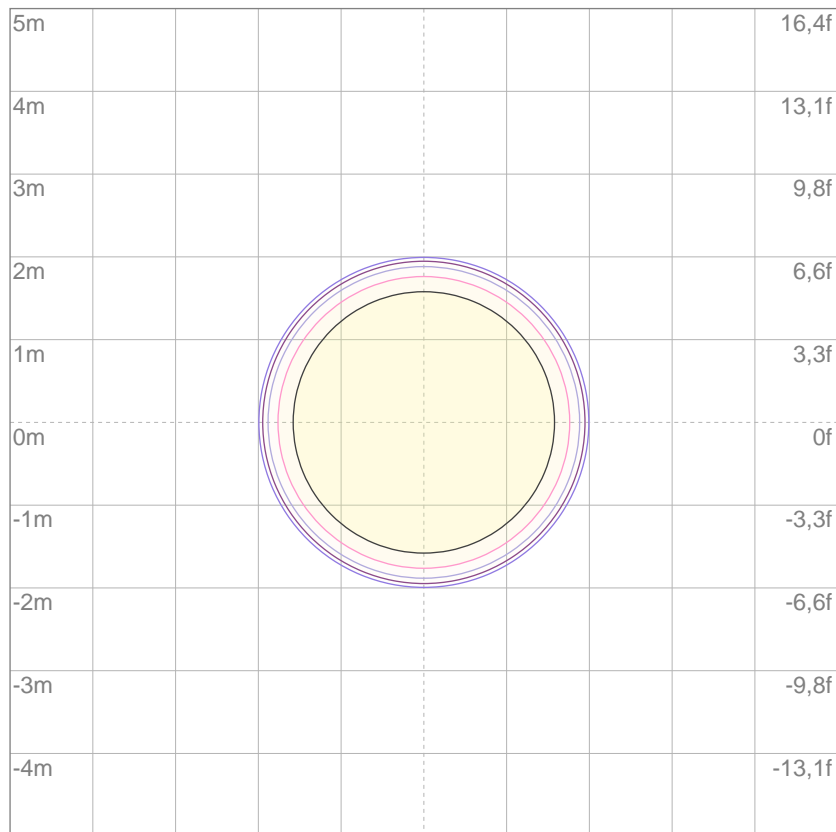

3%	1,26 lx
5%	2,10 lx
10%	4,20 lx
30%	12,6 lx
50%	21,0 lx

Conditions:

Number of c-planes: 2

Lux at center: 42,0 lx

Lux distribution on a surface when lamp is mounted at 10 meters from the surface.

Mounting height: 10 meters (33 feet)



Total lumen output:

284 lm

Peak candela output:

894 cd

Light quality:

CRI: 90,7

Color temperature:

6124 K

PRODUCT NAME:

ECLDISPLAYFC

MEASURAMENT CONDITIONS:

Beam angle:

Profile Max Zoom

Target:

6000K

Operator:

Paolo Carvone

Date and time:

14/01/2021 11:37:35

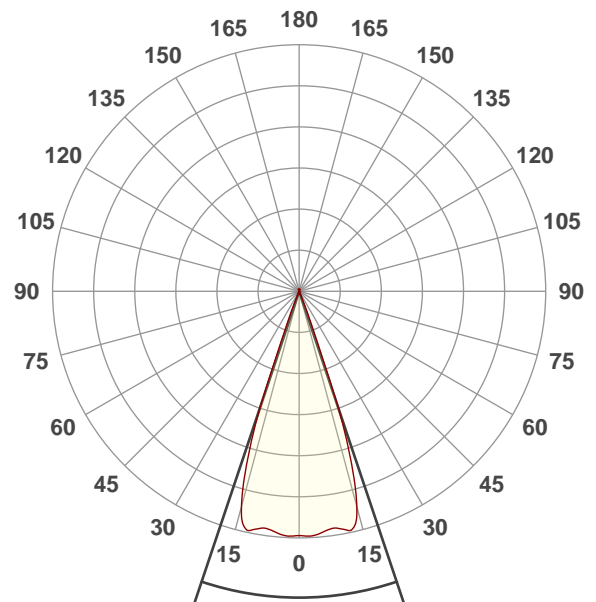

Beam angle 50%: 37,1°

Field angle 10%: 42°

Cut off angle 2.5%: 44,1°

Spectra

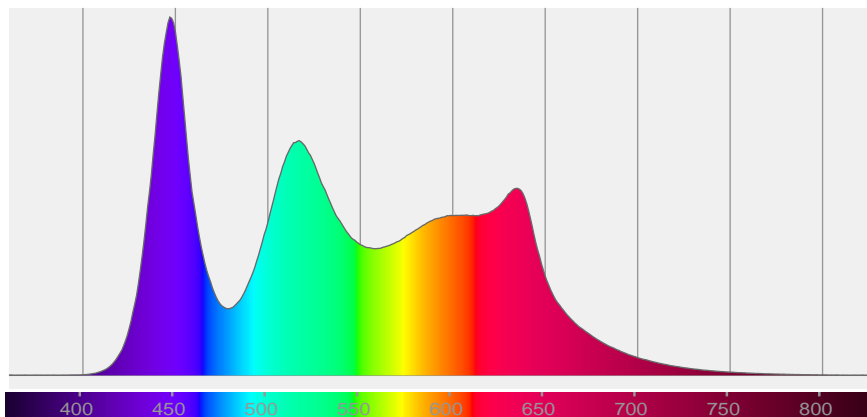

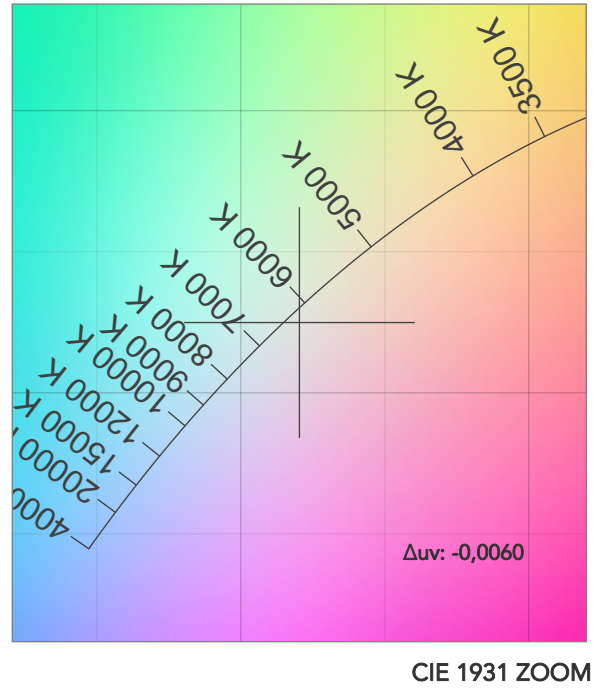
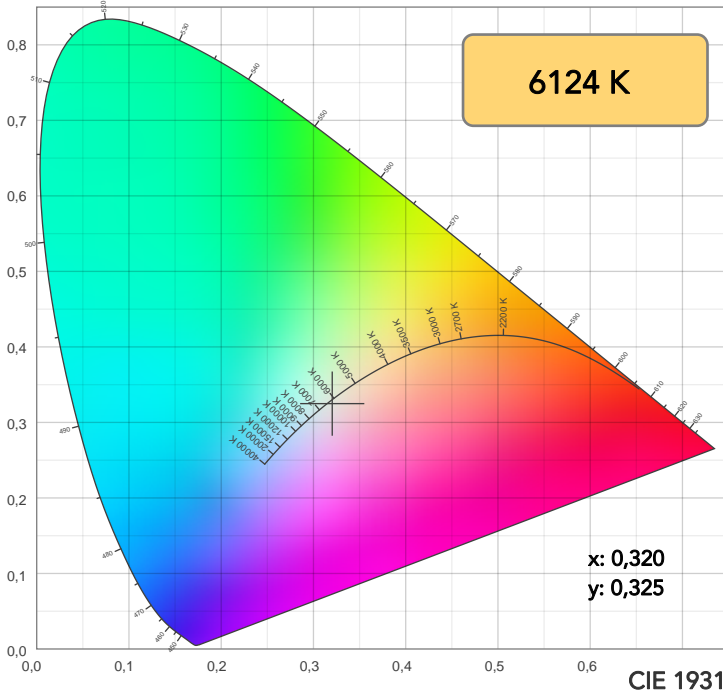

TM30: 90,1

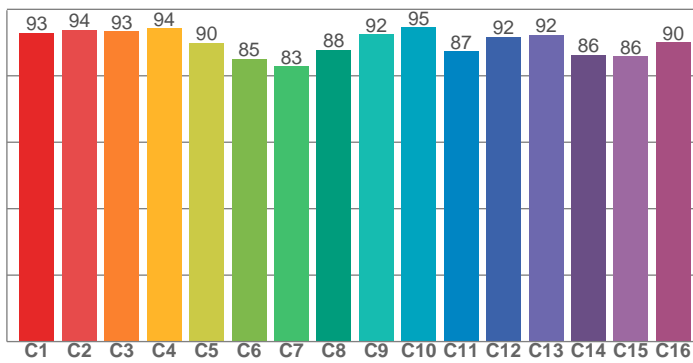

CRI: 90,7 (R1-R8)

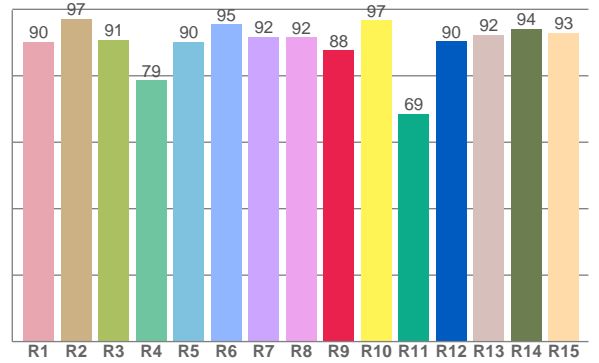

CRI R values, only R1-R8 are used to calculate final CRI value

R1	R2	R3	R4	R5	R6	R7	R8	R9	R10	R11	R12	R13	R14	R15
90,3	97,2	90,9	78,6	90,3	95,4	91,8	91,5	87,8	96,7	68,6	90,4	92,4	94,2	92,9

TM30 C values, 16 binned values out of total of 99 C values

C1	C2	C3	C4	C5	C6	C7	C8	C9	C10	C11	C12	C13	C14	C15	C16
92,9	93,8	93,4	94,3	90,0	85,1	82,8	87,8	92,4	94,6	87,3	91,7	92,4	86,3	85,9	90,0

CQS Q values

Q1	Q2	Q3	Q4	Q5	Q6	Q7	Q8	Q9	Q10	Q11	Q12	Q13	Q14	Q15
98,4	95,6	89,7	97,2	88,5	87,6	98,0	94,0	94,5	95,7	96,4	97,0	98,0	97,0	98,7

CQS: 94,0

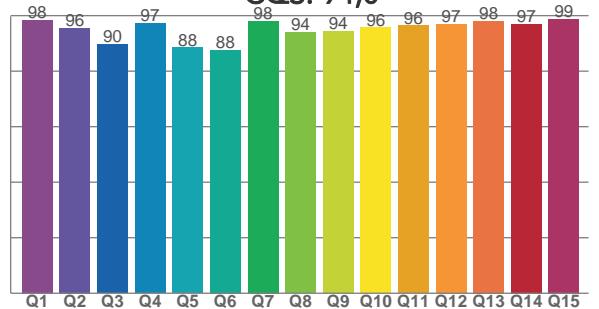

COLOR PARAMETERS

Color temperature	Color rendering index	Red component	Color fidelity	Color gamut	Color quality scale	Television lighting index	Color coordinate cie 1931	Color coordinate cie 1931	Color deviation from black body
CCT	CRI	CRI R9	TM30 Rf	TM30 Rg	CQS	TLCI	x	y	Δuv
6124 K	90,7	87,8	90,1	108,5	94,0	82	0,320	0,325	-0,0060

TM30 DETAILS

Rf 90,1
Fidelity index Rf

Rg 108,5
Gammut index

Hue Bin	R _f	Graphic shifts (%)	
		Chroma	Hue
1	93	2%	-2%
2	94	2%	0%
3	93	2%	2%
4	94	1%	2%
5	90	3%	3%
6	85	9%	5%
7	83	10%	1%
8	88	6%	-2%
9	92	3%	-4%
10	95	0%	-2%
11	87	1%	7%
12	92	2%	4%
13	92	5%	3%
14	86	6%	5%
15	86	11%	-3%
16	90	5%	-1%

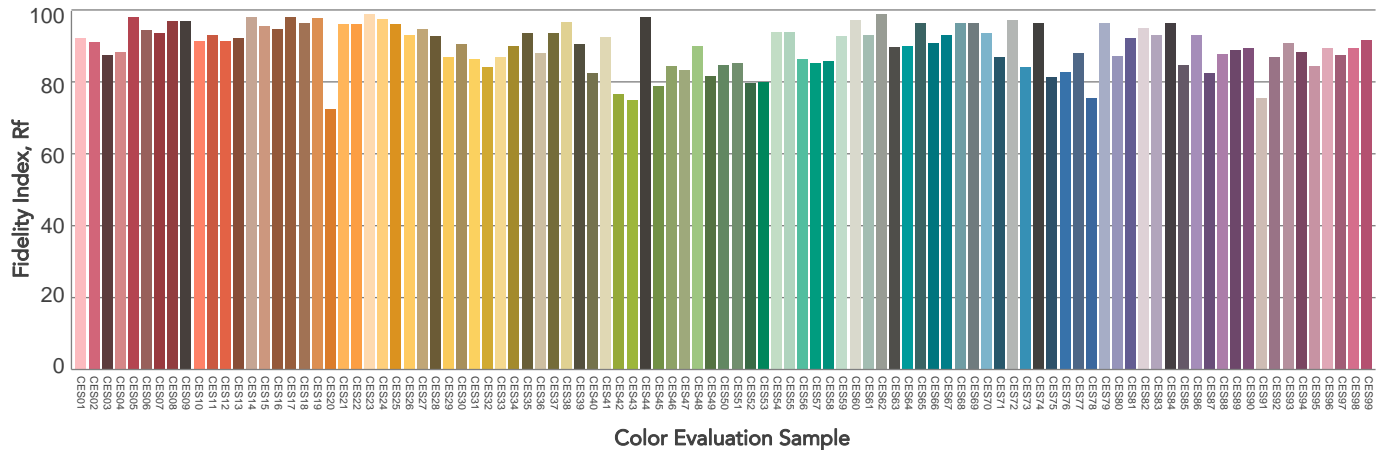
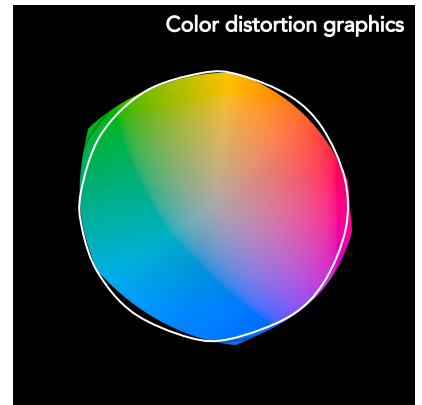
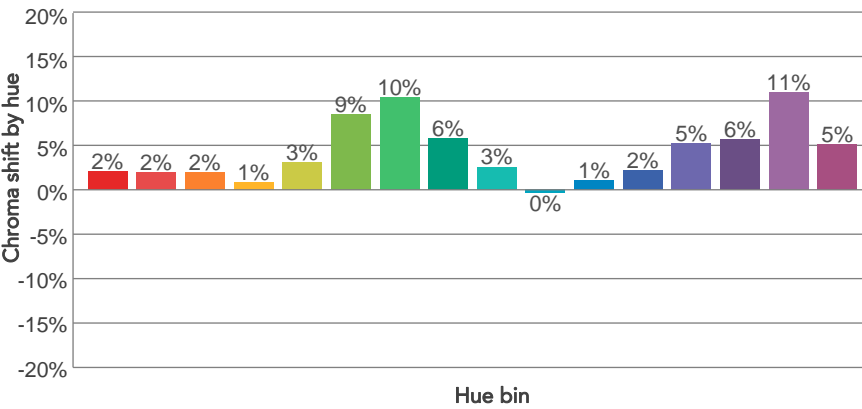
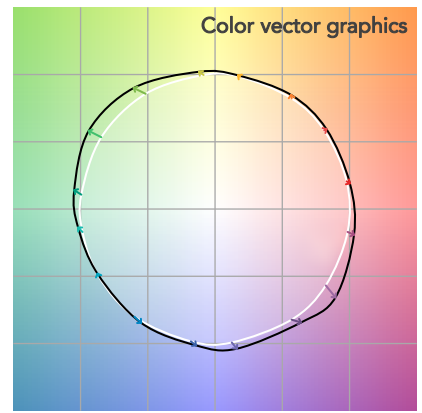
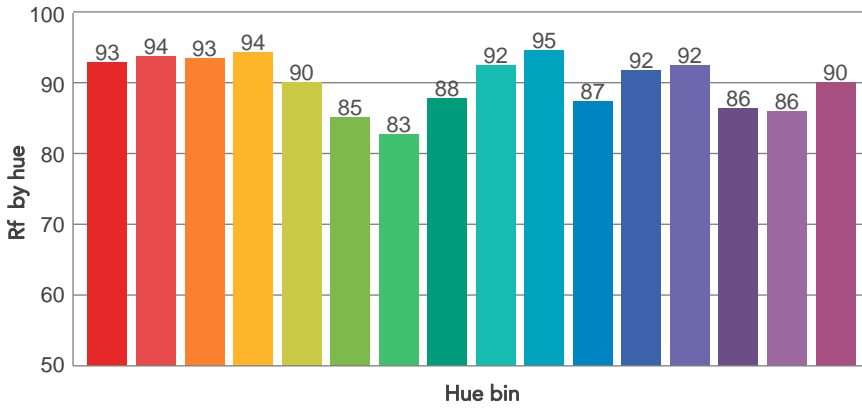
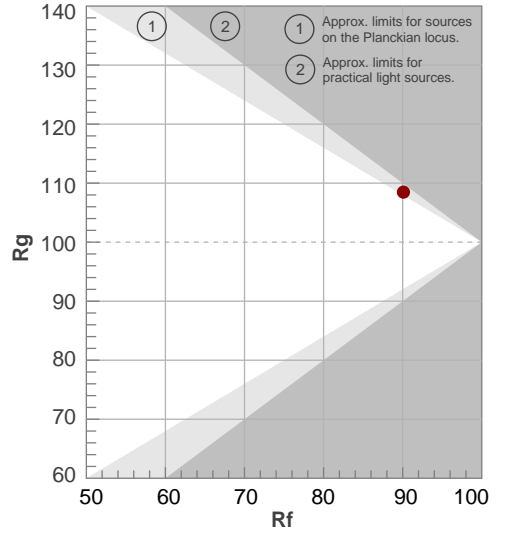

BEAM DETAILS



Beam angle 50%	Field angle 10%	Cut off angle 2,5%	Intensity ratio in 120° cone	Intensity ratio in 90° cone
37,1°	42°	44,1°	100,0%	100,0%

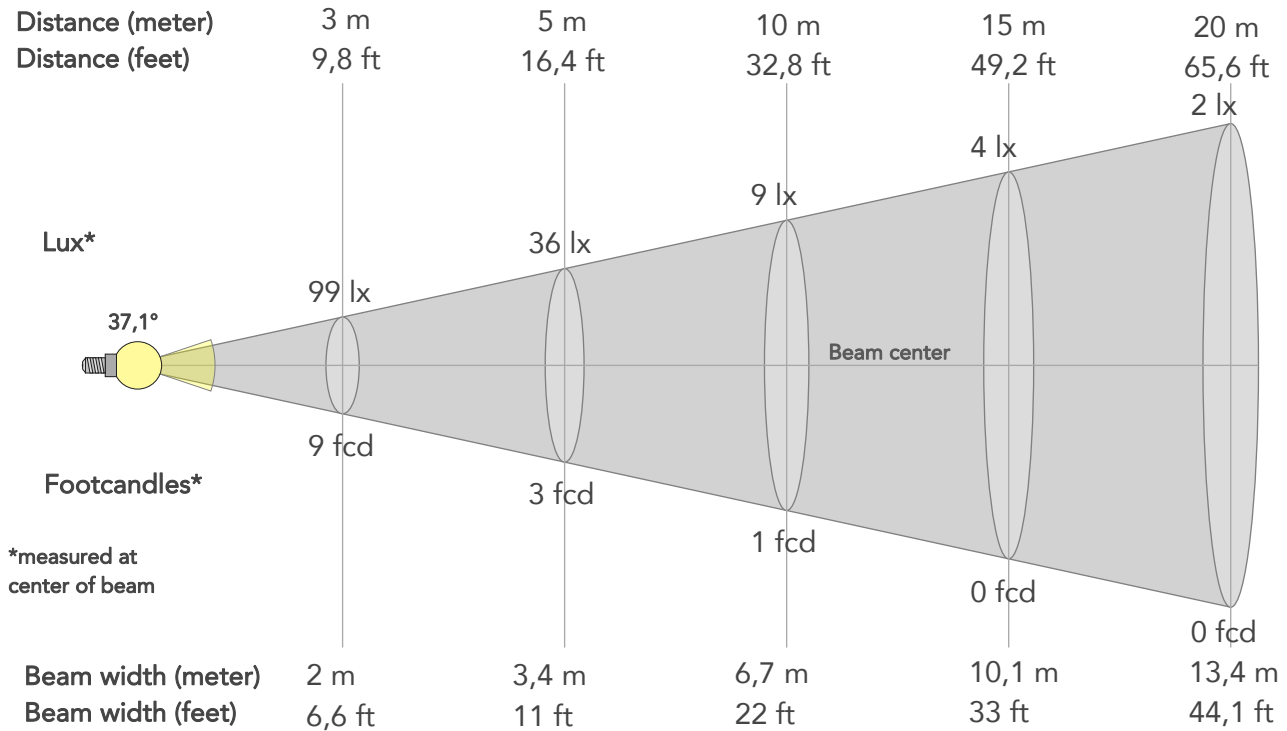

BEAM INTENSITIES AND WIDTHS

Distance	1m	2m	3m	4m	5m	7,5m	10m	15m	20m	25m	30m	40m	50m
Distance	3,3ft	6,6ft	9,8ft	13,1ft	16,4ft	24,6ft	32,8ft	49,2ft	65,6ft	82ft	98,4ft	131,2ft	164ft
Lux	892lx	223lx	99lx	56lx	36lx	16lx	9lx	4lx	2lx	1lx	1lx	1lx	0lx
Footcand.	83fcd	21fcd	9fcd	5fcd	3fcd	1fcd	1fcd	0fcd	0fcd	0fcd	0fcd	0fcd	0fcd
Beam wid.	0,7m	1,3m	2m	2,7m	3,4m	5m	6,7m	10,1m	13,4m	16,8m	20,2m	26,9m	33,6m
Beam wid.	2,2ft	4,4ft	6,6ft	8,8ft	11ft	16,5ft	22ft	33ft	44,1ft	55,1ft	66,1ft	88,1ft	110,2ft

LINEAR DISTRIBUTION DIAGRAM

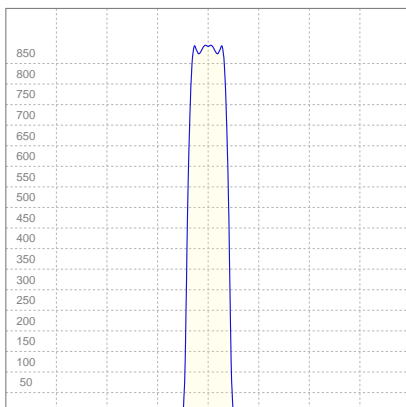

ELECTRICAL SPECIFICATIONS

Input voltage	Input current	Input power	Effeciency
223V	0,129A	26,7W	11lm/W

ISO CANDELA DIAGRAM

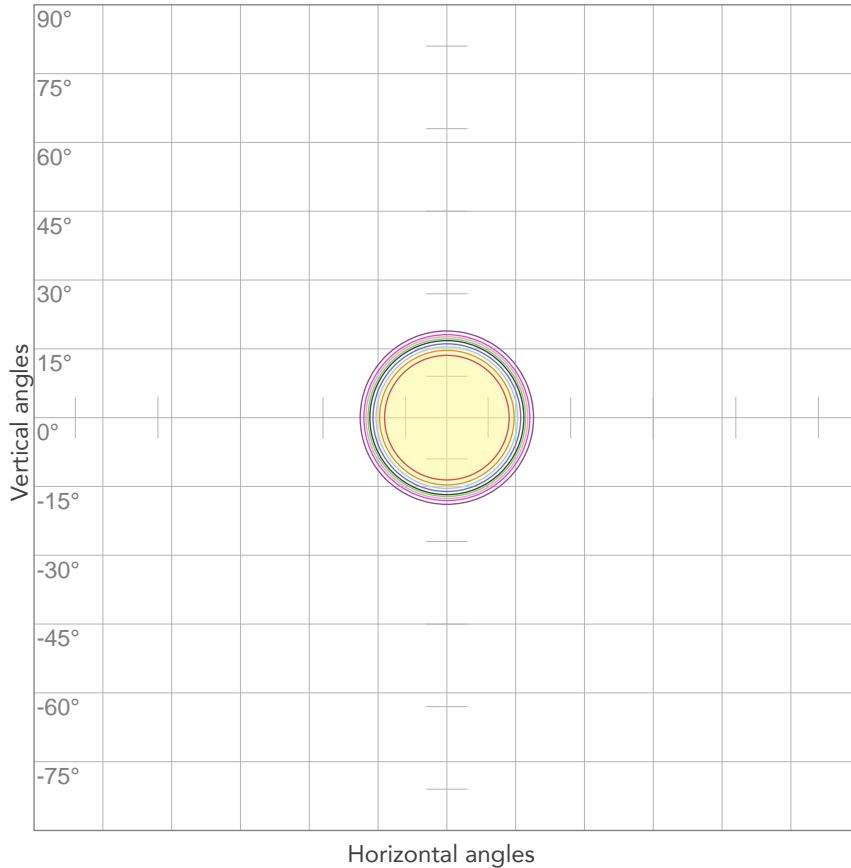

10%	89 cd
20%	178 cd
30%	268 cd
40%	357 cd
50%	446 cd
60%	535 cd
70%	624 cd
80%	713 cd

Conditions:

Number of c-planes: 2
Candela at center: 892 cd

ISO LUX DIAGRAM

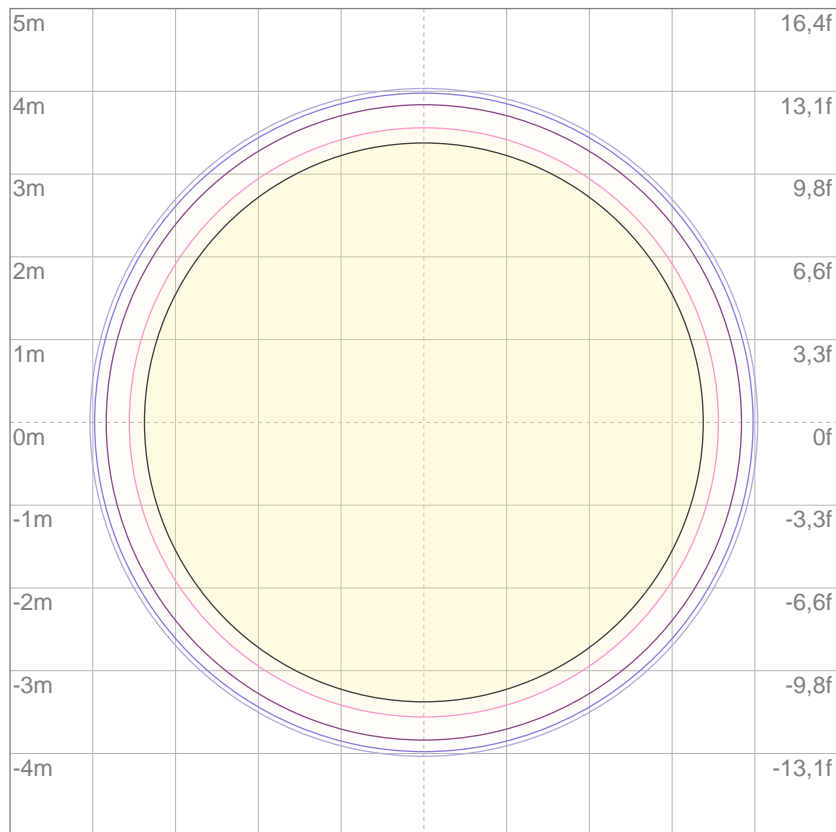

3%	0,268 lx
5%	0,446 lx
10%	0,892 lx
30%	2,68 lx
50%	4,46 lx

Conditions:

Number of c-planes: 2
Lux at center: 8,92 lx

Lux distribution on a surface when lamp is mounted at 10 meters from the surface.

Mounting height: 10 meters (33 feet)



Total lumen output:

315 lm

Peak candela output:

4274 cd

Light quality:

CRI: 90,7

Color temperature:

6130 K

PRODUCT NAME:

ECLDISPLAYFC

MEASURAMENT CONDITIONS:

Beam angle:

Profile Min Zoom

Target:

6000K

Operator:

Paolo Carvone

Date and time:

14/01/2021 11:26:49

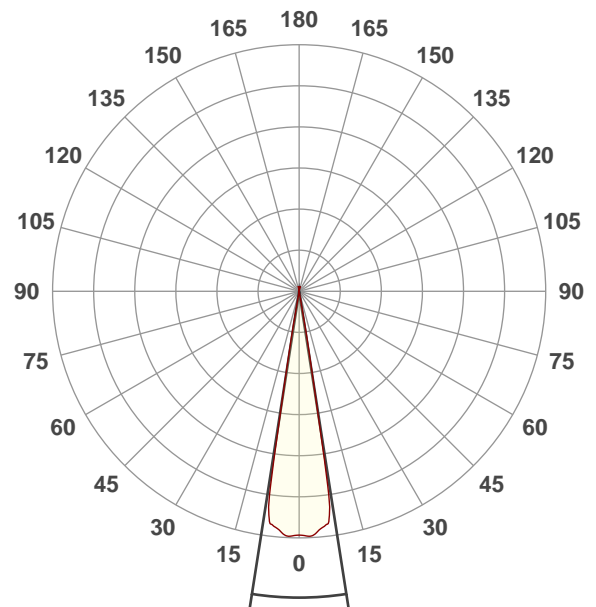

Beam angle 50%: 17,7°

Field angle 10%: 19,6°

Cut off angle 2.5%: 20,2°

Spectra

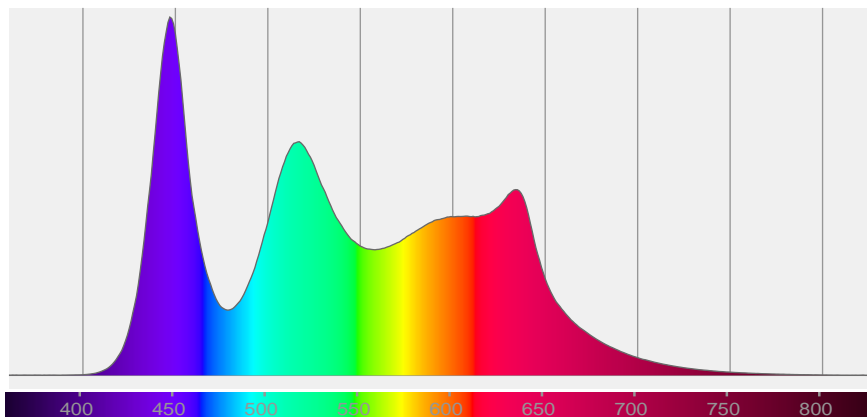

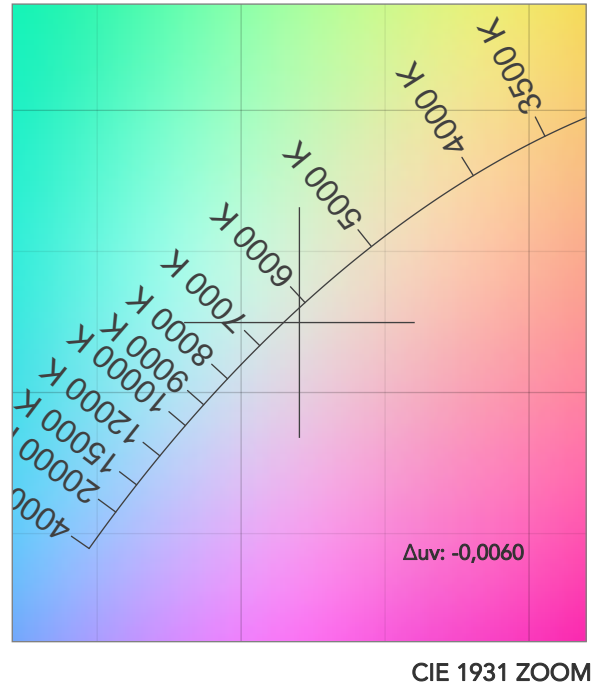
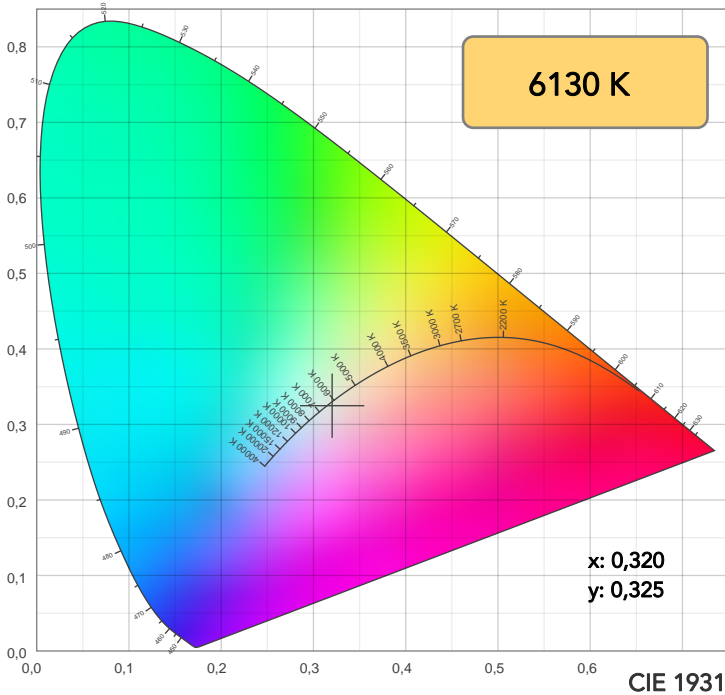

TM30: 90,0

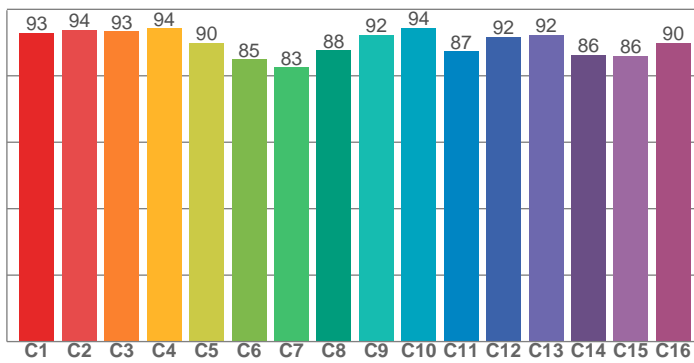

CRI: 90,7 (R1-R8)

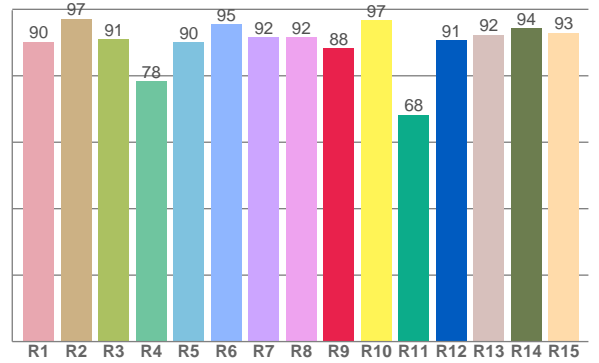

CRI R values, only R1-R8 are used to calculate final CRI value

R1	R2	R3	R4	R5	R6	R7	R8	R9	R10	R11	R12	R13	R14	R15
90,3	97,2	91,0	78,4	90,2	95,4	91,7	91,6	88,3	96,7	68,3	90,8	92,4	94,3	93,0

TM30 C values, 16 binned values out of total of 99 C values

C1	C2	C3	C4	C5	C6	C7	C8	C9	C10	C11	C12	C13	C14	C15	C16
92,8	93,7	93,3	94,2	89,8	84,9	82,5	87,6	92,2	94,4	87,4	91,7	92,4	86,3	85,9	90,0

CQS Q values

Q1	Q2	Q3	Q4	Q5	Q6	Q7	Q8	Q9	Q10	Q11	Q12	Q13	Q14	Q15
98,2	95,6	89,8	97,0	88,2	87,5	98,0	93,9	94,6	95,8	96,3	97,0	98,1	97,0	98,7

CQS: 93,9

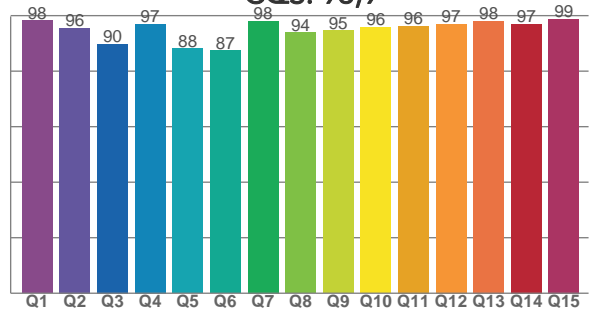

COLOR PARAMETERS

Color temperature	Color rendering index	Red component	Color fidelity	Color gamut	Color quality scale	Television lighting index	Color coordinate cie 1931	Color coordinate cie 1931	Color deviation from black body
CCT	CRI	CRI R9	TM30 Rf	TM30 Rg	CQS	TLCI	x	y	Δuv
6130 K	90,7	88,3	90,0	108,5	93,9	82	0,320	0,325	-0,0060

TM30 DETAILS

Rf 90,0
Fidelity index Rf

Rg 108,5
Gammut index

Hue Bin	R _f	Graphic shifts (%)	
		Chroma	Hue
1	93	2%	-2%
2	94	2%	0%
3	93	2%	2%
4	94	1%	2%
5	90	3%	3%
6	85	9%	5%
7	83	11%	1%
8	88	6%	-2%
9	92	3%	-4%
10	94	0%	-2%
11	87	1%	7%
12	92	2%	4%
13	92	5%	3%
14	86	6%	5%
15	86	11%	-3%
16	90	5%	-1%

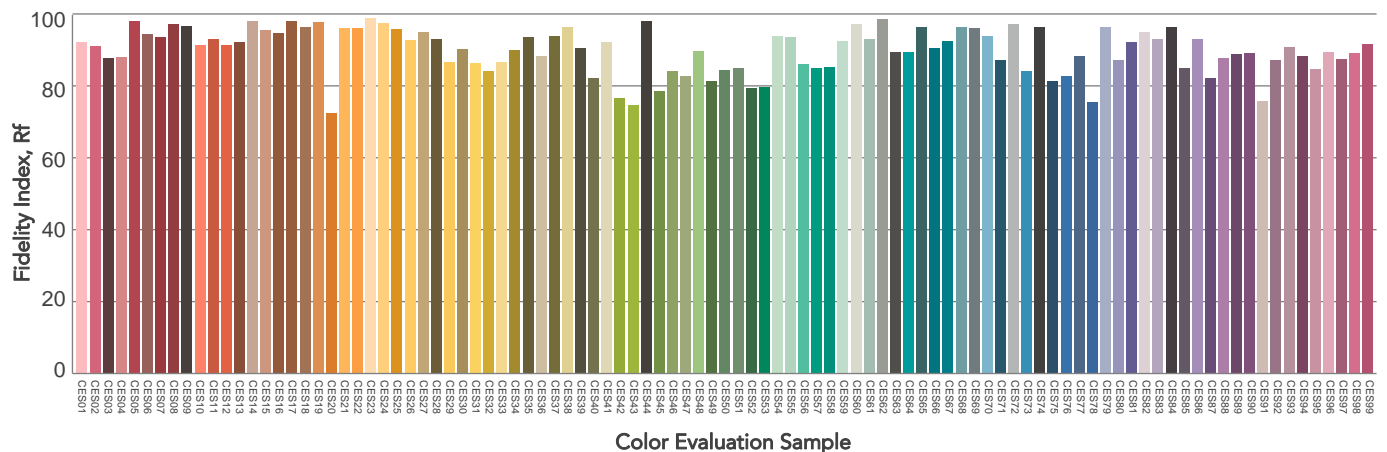
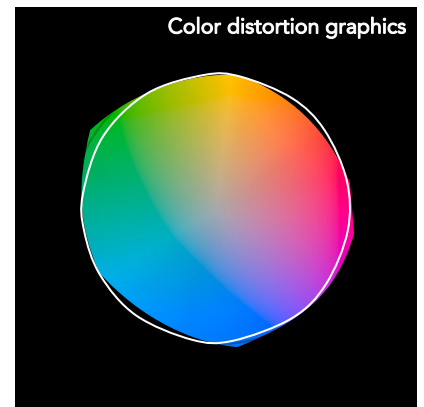
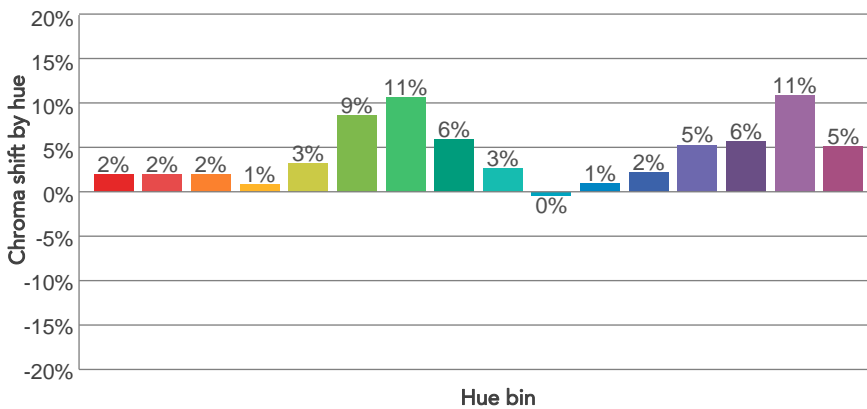
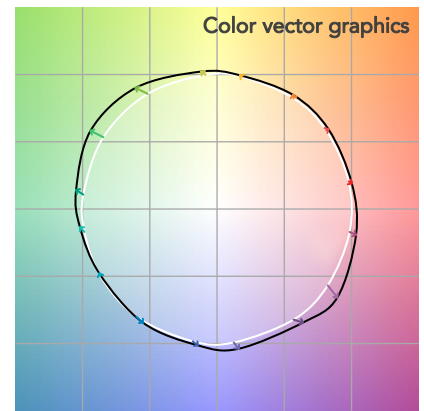
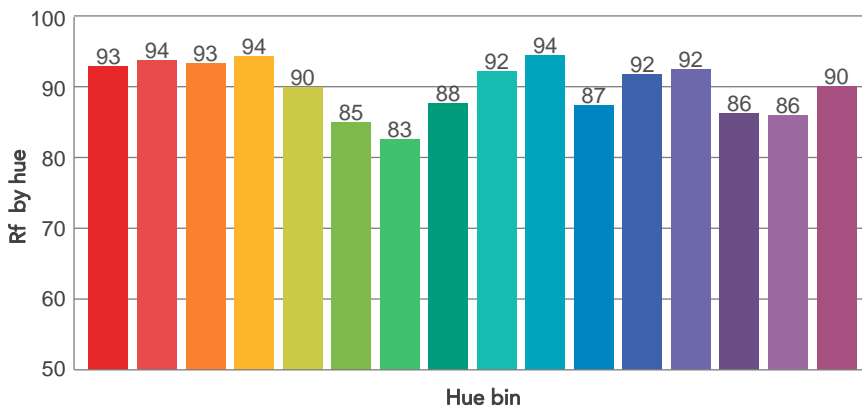
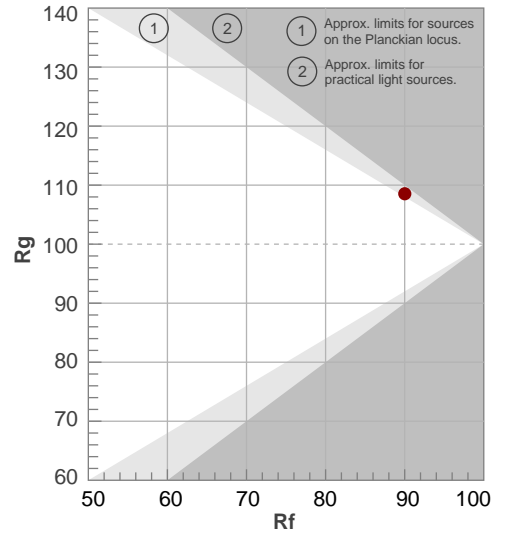

BEAM DETAILS



Beam angle 50%	Field angle 10%	Cut off angle 2,5%	Intensity ratio in 120° cone	Intensity ratio in 90° cone
17,7°	19,6°	20,2°	100,0%	100,0%

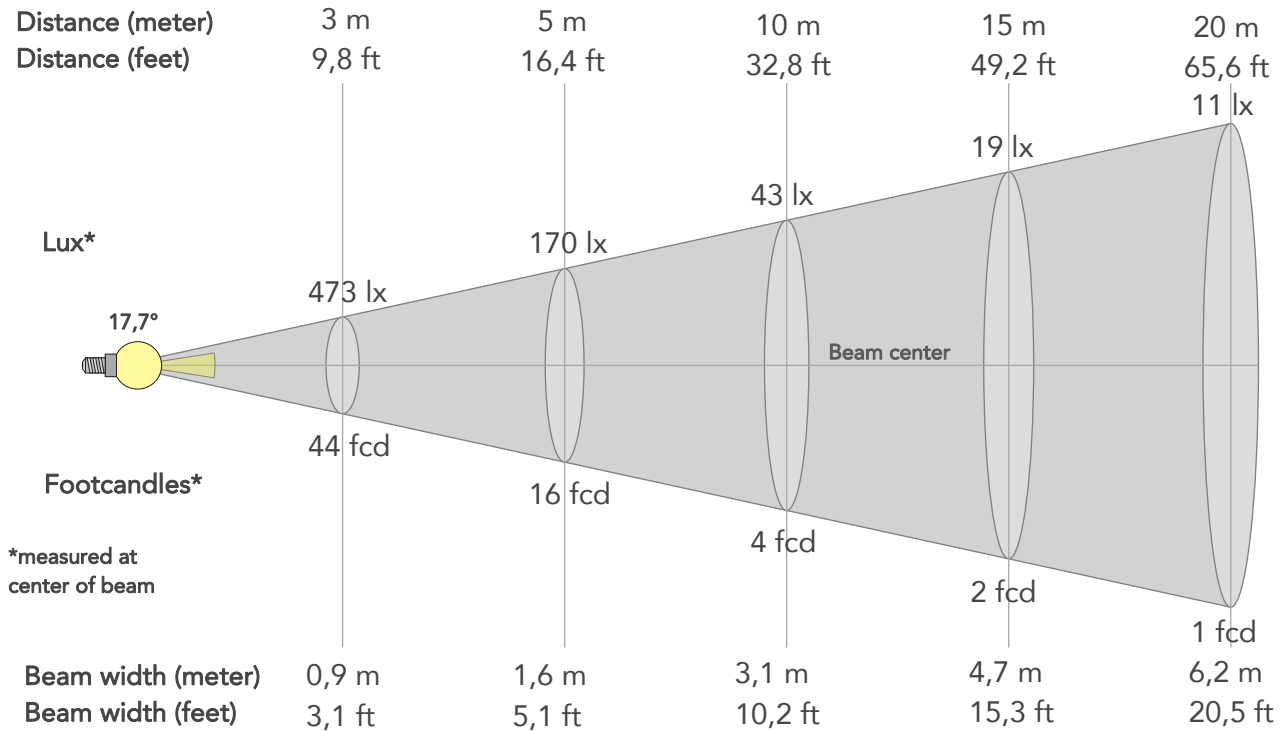

BEAM INTENSITIES AND WIDTHS

Distance	1m	2m	3m	4m	5m	7,5m	10m	15m	20m	25m	30m	40m	50m
Distance	3,3ft	6,6ft	9,8ft	13,1ft	16,4ft	24,6ft	32,8ft	49,2ft	65,6ft	82ft	98,4ft	131,2ft	164ft
Lux	4253lx	1063lx	473lx	266lx	170lx	76lx	43lx	19lx	11lx	7lx	5lx	3lx	2lx
Footcand.	395fcd	99fcd	44fcd	25fcd	16fcd	7fcd	4fcd	2fcd	1fcd	1fcd	0fcd	0fcd	0fcd
Beam wid.	0,3m	0,6m	0,9m	1,2m	1,6m	2,3m	3,1m	4,7m	6,2m	7,8m	9,4m	12,5m	15,6m
Beam wid.	1ft	2,1ft	3,1ft	4,1ft	5,1ft	7,7ft	10,2ft	15,3ft	20,5ft	25,6ft	30,7ft	40,9ft	51,2ft

LINEAR DISTRIBUTION DIAGRAM

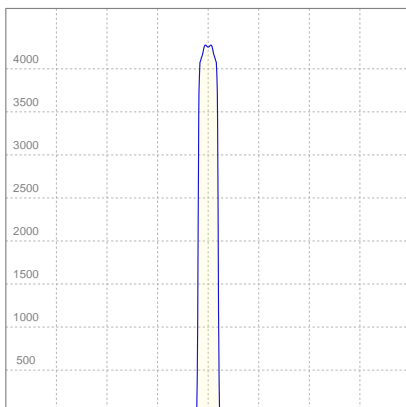

ELECTRICAL SPECIFICATIONS

Input voltage	Input current	Input power	Effeciency
224V	0,130A	26,8W	12lm/W

ISO CANDELA DIAGRAM

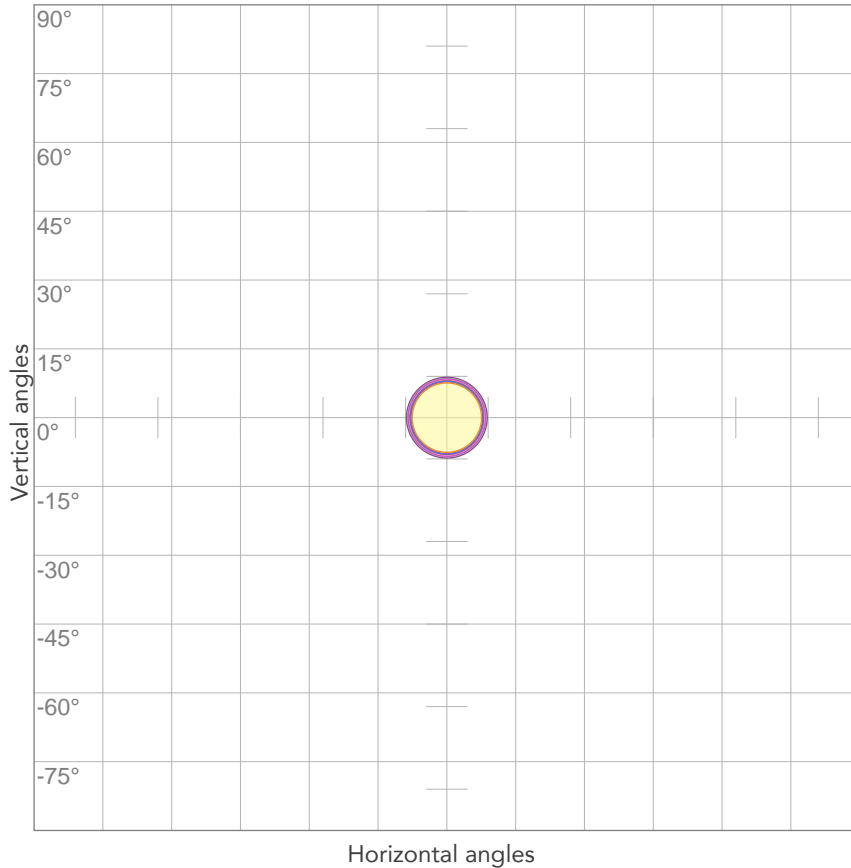

10%	425 cd
20%	851 cd
30%	1276 cd
40%	1701 cd
50%	2126 cd
60%	2552 cd
70%	2977 cd
80%	3402 cd

Conditions:

Number of c-planes: 2

Candela at center: 4253 cd

ISO LUX DIAGRAM

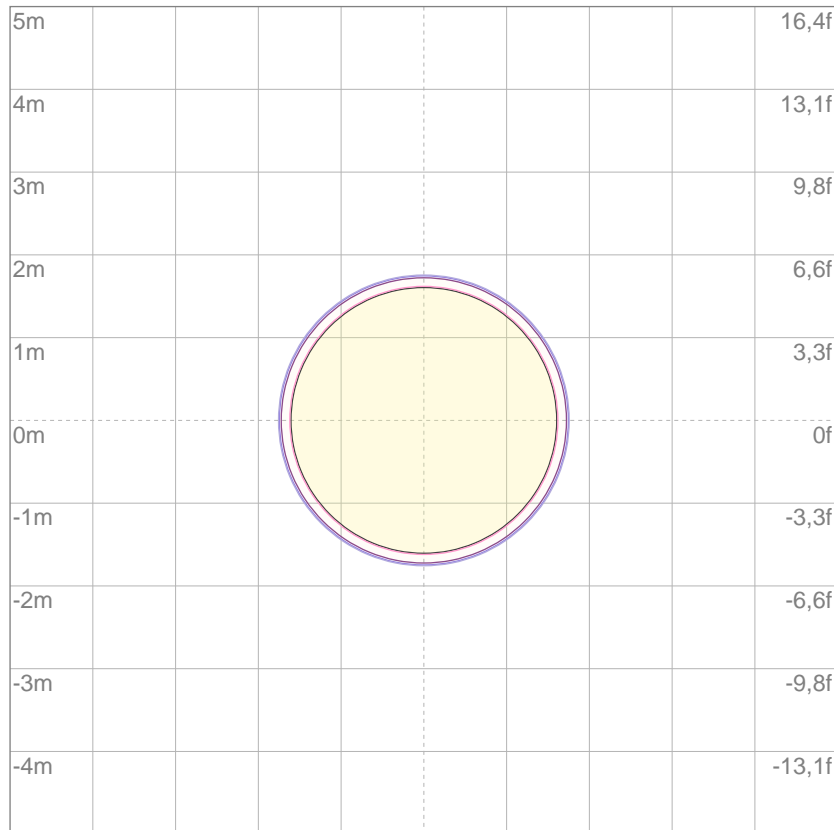

3%	1,28 lx
5%	2,13 lx
10%	4,25 lx
30%	12,8 lx
50%	21,3 lx

Conditions:

Number of c-planes: 2

Lux at center: 42,5 lx

Lux distribution on a surface when lamp is mounted at 10 meters from the surface.

Mounting height: 10 meters (33 feet)